

Lifesaving related 'M' Notices referred to in Marine Survival 3<sup>rd</sup> Edition

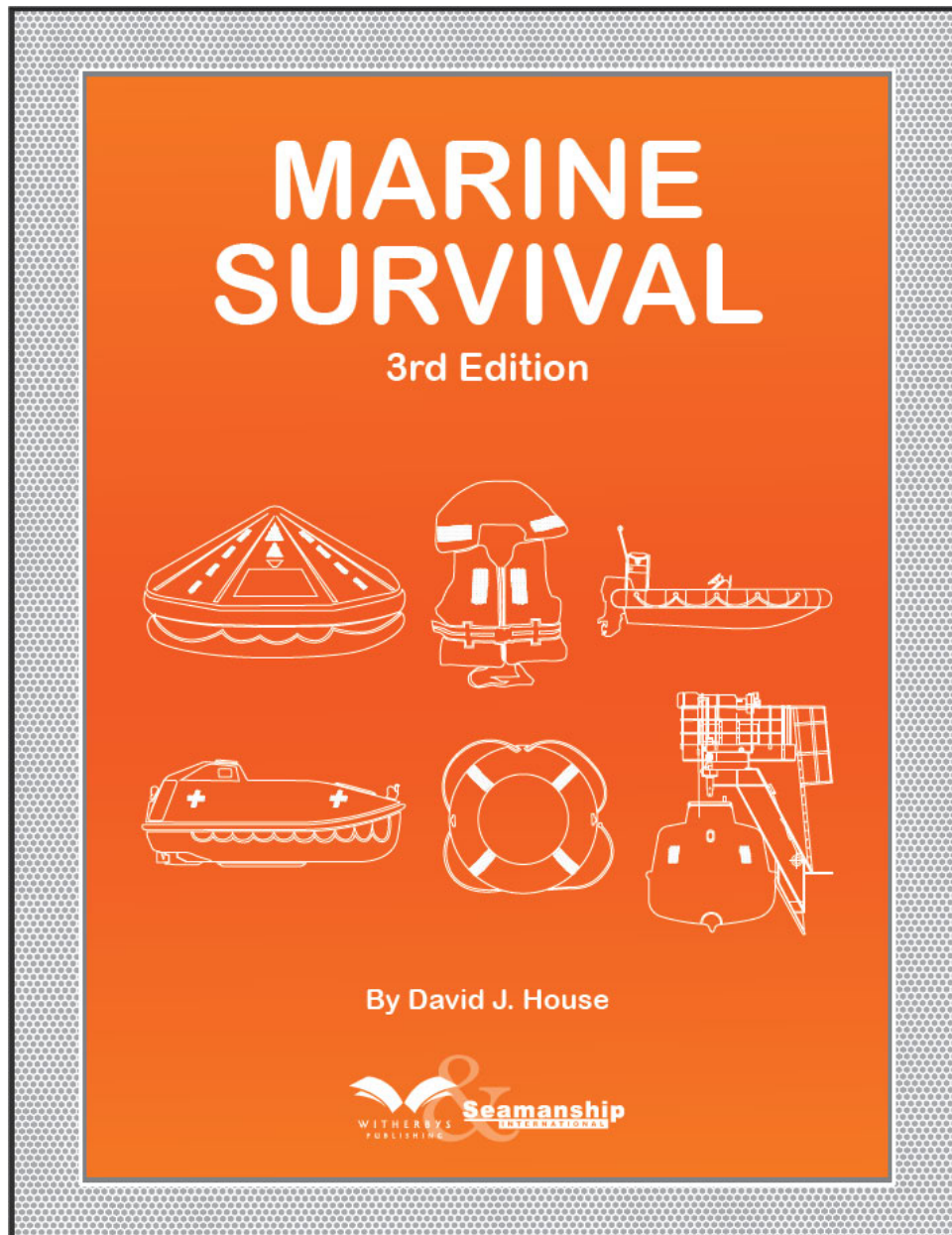

For further details of the book, visit: [www.witherbyseamanship.com](http://www.witherbyseamanship.com)

## **Additional reference to: – Relevant Merchant Shipping Notices:**

<b>M' Notice Number</b>	<b>Title</b>	<b>Page</b>
MGN 0071 (M)	Musters, drills, on-board training and instructions, and Decision Support Systems	1
MGN 0076 (M)	Lifejackets carried on Passenger Ships	14
MGN 0077 (M+F)	Instructions for Action in Survival Craft	16
MGN 0078 (M+F)	Launching Crews for Lifeboats, Rescue Boats, Class C Boats, Inflatable Boats and Other Boats	20
MGN 0083 (M)	Guidelines and Specifications for Hyperbaric Evacuation Systems	22
MGN 0105 (M+F)	Use and Fitting of Retro-Reflective Material on Life-Saving Appliances	34
MGN 106 (M+F)	Natural & Synthetic Fibre Cordage for Life-Saving Appliances	39
MGN 127 (M+F)	Means of Recovering Casualties From the Sea when Involved in Ship to Ship Personnel Transfers	44
MGN 141 (M)	Equivalent Arrangements for the Carriage of Man-Overboard Smoke Signals and Parachute Flares on Certain Class VI Passenger Vessels	46
MGN 161 (M+F)	Search and Rescue Helicopter Hi-Line Technique	47
MGN 0254 (M+F)	Guidance to Users of Inflatable Lifejackets	49
MGN 0273 (M)	Operational Issues relating to Marine Evacuation Systems	51
MGN 0419 (M+F)	Disposal of Out of Date Pyrotechnics	55
MGN 294 (M+F)	Use of GMDSS Equipment in General Communications	57
MGN 304 (M+F)	Shore-to-Ship Communications During a Distress	59
MGN 0325 (M)	Helicopter Assistance at Sea	61
MGN 0329 (M)	Lifejackets "Infant and Oversized Passengers"	66
MGN 0343 (M+F)	Hydrostatic Release Units (HRU) - Stowage and Float Free Arrangements for Inflatable Liferrafts	72
MGN 0344 (M)	Observations and Recommendations arising from a Series of Domestic Passenger Vessel Evacuation Exercises	83
MGN 0362 (M+F)	Servicing of Inflatable Liferrafts, Inflatable Boats, Rescue Boats, Fast Rescue Boats, Inflatable Lifejackets and Hydrostatic Release Units.	91
MGN 0396 (M+F)	Compatibility of Life-saving Equipment	107
MSN 1186 (M+F)	Lifeboat Winches Fitted with a Roller Ratchet Mechanism	111

MSN 1359 (M+F)	Emergency Equipment Lockers for RoRo Passenger Ships	113
MSN 1386 (M)	Emergency Information for Passengers on Passenger Ships of Classes III, IV, V, VI and VI(A)	115
MSN 1409 (M)	Emergency Information for Passengers	120
MSN 1414 (M+F)	Carriage of Additional Lifejackets	126
MSN 1522 (M+F)	Life-Saving Appliances - The Provision of Rescue Boats on Ships Fitted with Free-fall Lifeboats	127
MSN 1579 (M)	Minimum Training Requirements for Personnel Nominated to Assist Passengers in Emergency Situations	128
MSN 1676 (M)	The Merchant Shipping (Life-Saving Appliances for Ships Other Than Ships of Classes III to VI(A)) Regulations 1999 The Merchant Shipping (Life-Saving Appliances for Passenger Ships Other Than Ships of Classes III to VI(A)) Regulations 1999	131
MSN 1677 (M)	The Merchant Shipping (Life-Saving Appliances for Ships Other Than Ships of Classes III to VI(A)) Regulations 1999	241
MSN 1722 (M+F)	Guidelines for Training Crews for the Purpose of Launching Lifeboats and Rescue Boats from Ships Making Headway through the Water	281
MSN 1783 (M)	Arrangements for the Carriage of Agreed Search and Rescue Co-Operation Plans Aboard UK Passenger Vessels	285
MSN 1803 (M)	LIFEBOATS - Measures to Prevent Accidents	309
MSN 1816 (M+F)	Mandatory Registration of Emergency Position Indicating Radio Beacons (EPIRBs)	329



Maritime and Coastguard Agency

---

---

## Musters, drills, on-board training and instructions, and Decision Support Systems

Notice to Owners, Masters, Officers and Ratings

*This Note Replaces Marine Guidance Note MGN 17 (M) and should be read in association with MGN 5 and MGN 6.*

---

---

### Summary

This note and annex provides guidance to the relevant requirements in the Regulations listed in paragraph 1 in respect of:

1. muster lists, the holding of musters and drills and the provision of on-board training and instruction in the use of fire and life-saving appliances, and the provision of a Decision Support System to Masters of certain passenger ships;
2. the provision of training manuals, and for the manning of survival craft and handling of launching arrangements; and
3. the closing of openings in the hull and in watertight bulkheads.

1. The statutory requirements primarily associated with the recommendations and guidance in the Annex to this Notice are prescribed in the following Regulations:

(a) The Merchant Shipping (Musters Training and Decision Support Systems) Regulations 1999 (SI.1999 No.2722) which contains requirements in respect of muster lists, the holding of musters and drills and the provision of on-board training and instruction in the use of fire and lifesaving appliances, and the provision of a Decision Support System to Masters of certain passenger ships;

(b) The Merchant Shipping (Life-Saving Appliances for Ships Other Than Ships of Classes III to VI(A)) Regulations 1999 (SI.1999 No.2721), and the Merchant Shipping (Life-saving Appliances for Passenger Ships of Classes III to VI(A))

Regulations 1999 (SI.1999 No.2723), which contain requirements in respect of the provision of training manuals, and for the manning of survival craft and handling of launching arrangements; and

(c) The Merchant Shipping (Passenger Ship Construction: Ships of Classes I, II and II(A)) Regulations 1998 (SI.1998 No.2514) which contain requirements in respect of the closing of openings in the hull and in watertight bulkheads.

2. The Regulations referred to in subparagraphs 1(a) and (b) above implement the 1983 and 1988 and 1996 Amendments to Chapter III of the International Convention for the Safety of Life at Sea 1974. One of the principal objectives of the 1983 Amendments to the Convention was to prescribe minimum standards of training and instruction, in particular on-board training in the use of ship's fire appliances, ship's life-saving

appliances including launching and embarkation equipment, in methods of survival and in the use of personal protective equipment. An essential part of such training and instruction involves participation in periodic practice musters and drills. The 1996 Amendment introduced the requirement for Decision Support Systems for Masters of certain passenger ships.

3. The purpose of this Note and its Annex is to draw attention to relevant requirements in the Regulations listed in paragraph 1 and to specify how such requirements should be met.

MSPP2c  
Maritime and Coastguard Agency  
Spring Place  
105 Commercial Road  
Southampton  
S015 1EG

Tel: 01703 329184  
Fax: 01703 329204

October 1999

MS 050/005/0005

© Crown Copyright 1999



*An executive agency of the Department of the  
Environment, Transport and the Regions*

## ANNEX

### Section CONTENTS

1	Application
2	Muster Lists
3	Emergency Instructions
4	Emergency Signals
5	Musters and Drills - General
6	Abandon Ship Drills
7	Fire and other Emergency Drills
8	Drills in Closing of Doors, Side Scuttles and Other Openings
9	Survival Craft Muster and Drill
10	Survival Craft Drills held in Port
11	Rescue Boat and Emergency Boat Drills
12	Davit-Launched Liferaft On-Board Training
13	On-Board Instruction, Training and Training Manuals
14	Weekly and Monthly Inspection of LSA
15	Decision Support Systems
16	Records

#### 1 Application

1.1 Except where otherwise specified the contents of this Annex are addressed to ships of Classes I, II, II(A), III, VII, VII(A), VII(T), VIII, VIII(T), VIII(A), VIII(A)(T) and IX and to ships of Class XI engaged on international voyages.

#### 2 Muster Lists

2.1 The requirements relating to muster lists apply to ships engaged on international voyages and to passenger ships of Classes II(A) and III. The Master is responsible for compiling the muster list, keeping it up to date and ensuring that copies are exhibited in conspicuous places

throughout the ship, including the navigating bridge, engine room and crew accommodation. The format of muster lists for ships of Classes I, II, II(A) and III must be approved by the Maritime and Coastguard Agency (MCA).

2.2 In ships with significant numbers of non-English speaking crew members, the muster list should include translations into the appropriate language or languages.

2.3 The muster list must contain details of the general emergency alarm and other emergency signals and the action to be taken by the crew and passengers in respect of the former, and by the crew in respect of the latter. Where appropriate, communication equipment, channels and reporting chain to be used during an abandonment or other emergency should be specified. The means by which the order to abandon ship is to be given must also be included.

2.4 The muster list must show the duties to be carried out by each member of the ship's complement in an emergency. Such duties include the preparation, swinging out or deploying of survival craft and other life-saving appliances, the closing of watertight and fire doors, and all other openings such as skylights, portholes and side scuttles and any openings in the hull. Duties in connection with fire-fighting, the use of communication equipment and the equipping of survival craft must also be shown.

2.5 Where passengers are carried duties include warning and assembling passengers, controlling their movement, seeing that they are suitably clad and wearing their lifejackets correctly or, where appropriate, distributing and assisting with the donning of lifejackets, and, where carried, taking a supply of blankets to the survival craft.

2.6 In assigning crew members to assist passengers in emergency situations on ships of Classes I, II, II(A) and III masters should ensure that all such personnel have received instruction in crowd management.

2.7 As far as practicable each individual should only be allocated one duty, or series of duties related to one emergency party. On passenger ships key persons who would be last to abandon ship should not be allocated to those survival craft which are expected to be the first to be launched.

2.8 When the muster list is compiled consideration should be given to the eventuality of key persons being unable to carry out their emergency duties through injury or for some other reason, and provision made for substitutes. This provision must be shown on the muster list and may be a detailed list or in the form of a general statement such as "Should key persons become disabled, those next in line, as appropriate, should take their place". When allocating substitutes care should be exercised to ensure that emergency parties are not left without a leader or seriously undermanned.

2.9 The survival craft or launching station to which each crew member is assigned should be shown on the muster list.

2.10 In assigning crew members to man survival craft and handle launching appliances on ships engaged on international voyages and on passenger ships of Classes II(A) and III, the Master should take account of Merchant Shipping Notice MSN 1682 (M).

2.11 A deck officer or certificated person must be placed in charge of each survival craft to be used and a deck officer or certificated person must be assigned as second-in-command of a lifeboat. In ships of Classes II, II(A) and III a person practiced in the handling and operation of liferafts may be placed in charge of a liferaft in lieu of a deck officer or certificated person. The person in charge of the survival craft shall have a list of the survival craft crew and shall see that the crew under his command are acquainted with their duties. In lifeboats the second-in-command shall also have a list of the lifeboat crew.

2.12 A motor lifeboat must have a person assigned to it who is capable of operating the engine and carrying out minor adjustments. This person may be the coxswain if it is possible to operate the engine and steer the lifeboat from one position. A lifeboat with a radio installation and each survival craft in which are placed emergency position-indicating radio beacons (EPIRBs), radar transponders (SARTs), or two-way radio-telephone sets is required to have a person assigned to it who is capable of operating such equipment.

2.13 The muster list must show the name or rank of the officers whose duty is to ensure that the life-saving and fire-fighting appliances are maintained in such condition as to be always ready for use.

2.14 In passenger ships, the location of the passenger assembly or muster station (as appropriate) must be indicated in the muster list. As far as practicable, public rooms will be allocated as assembly or muster station (as appropriate) in order that passengers are protected from the elements prior to their departure for the survival craft if the ship has to be abandoned.

2.15 The master shall ensure the equitable distribution of persons referred to in paragraph 2.6, 2.10 and 2.11 among the ship's survival craft.

### **3 Emergency Instructions**

3.1 In ships engaged on international voyages and in passenger ships of Classes II(A) and III, each crew member must be provided with clear instructions to be followed in the event of an emergency, eg in the form of a card showing the assembly or muster station (as appropriate) station, emergency duty and the lifeboat or liferaft to which he is allocated. In ships with significant numbers of non-English speaking crew members emergency instructions should be provided in the appropriate language or languages. The card or other means should describe the general emergency alarm signal and any other signals to be used in an emergency and the action, if any, to be taken on hearing such signals. The means by which the order to abandon ship is to be given should also be included.

3.2 Emergency instructions, illustrated where possible, must be displayed in each passenger cabin, in passenger assembly or muster station (as appropriate) stations and in other passenger spaces. Such instructions, in English and in any other language appropriate to the principal nationalities carried on the route on which the ship is operating, are to inform passengers of their assembly or muster station (as appropriate) stations, essential actions they should take on hearing the general emergency alarm signal and any other signal requiring action on their part, and the method of donning lifejackets. The location of lifejackets should be included in these instructions. Safety information to be provided to passengers is detailed in Merchant Shipping Notices M.1386 (to be replaced by MGN 73) and M.1409 (to be replaced by MGN 74).

### **4 Emergency Signals**

4.1 The general emergency alarm signal is the signal for summoning the crew and

passengers, if any, to their assembly or muster station (as appropriate) stations and for initiating the actions shown in the muster list. This signal consists of seven or more short blasts followed by one long blast sounded on the ship's whistle or siren and on a bell, klaxon or similar warning system on ships required to be provided with such systems.

4.2 On a cargo ship with a fire alarm system which can be manually activated from locations within the accommodation or where a system such as a fire or smoke detection system automatically activates alarms throughout the ship, the signal made by such means may be used to summon the crew to their muster stations. Such alarm signal should be accompanied by the general emergency alarm signal sounded on the whistle or siren.

4.3 Signals for incidents not requiring a muster of the passengers or of the whole crew, or for dealing with a minor incident, are at the Master's discretion.

4.4 On a cargo ship a signal may be allocated to summon the crew to survival craft embarkation stations only, for the purpose of a drill or mustering the crew at the survival craft embarkation stations during an emergency.

4.5 The means by which the order to abandon ship is given is at the Master's discretion and may be by a signal or by word of mouth, but arrangements should be such that everyone on board including those in emergency parties in remote locations will receive it.

4.6 All signals must be described in the muster list, in the crew emergency instructions and, as appropriate, in the emergency instructions for passengers.

4.7 The relevant signals referred to in this section should be used when musters and drills are to be conducted. All persons on board should be notified beforehand that a practice muster or drill is about to be held.

## 5 Musters and Drills - General

5.1 An abandon ship drill consists of a muster of the crew (and of passengers, if appropriate) at the stations referred to in the muster list, and a muster and drill at survival craft stations. Where practicable, passengers on Class I passenger ships should be strongly

encouraged to attend abandon ship drills. It is recommended that a fire drill be held simultaneously with the first stage of the abandon ship drill. Drills for emergencies other than fire, eg collision, damage control, grounding, cargo or bunker spillage, rescue of personnel from dangerous spaces, or medical treatment, may be conducted in lieu of or in addition to a fire drill, provided each crew member participates in at least one fire drill each month. Whether a fire or other emergency drill is to be conducted, it may be found useful on occasions to discuss beforehand, with those taking a direct part in the drill, the object and execution of the drill in order that those taking part can derive the maximum benefit from the drill. When planning procedures and associated drills dealing with rescue of personnel from dangerous spaces, account should be taken of Chapters 16 and 17 of the Code of Safe Working Practices for Merchant Seamen, 1998 Edition.

5.2 Each crew member must participate in at least one abandon ship drill and one fire drill every month. These drills must be held within 24 hours of leaving port if more than 25% of the crew have not taken part in drills on board the ship in the previous month. If circumstances are such that it is not practical to hold full drills within the 24 hours then musters should be held within this period and instructions given to crew members on their emergency duties and on abandon ship procedures, but in the case of Ro-Ro passenger ferries these instructions should be given before any passenger carrying voyage is commenced. Full drills should be held as soon as circumstances permit. In addition, in ships of Classes I, II, II(A) and III, an abandon ship drill and a fire drill must be held weekly and as many of the crew as practicable should take part in these drills which should be so arranged that each crew member participates in at least one abandon ship drill and one fire drill every month.

5.3 On any ship carrying passengers where the passengers are scheduled to be on board for more than 24 hours, a muster of the passengers must take place within 24 hours of their embarkation. Passengers must be given instruction in how to don their lifejackets and the action to take on hearing the general emergency alarm signal. If only a small number of passengers embark after the muster has been held, it will be sufficient, instead of holding another, to draw the attention of these passengers to the emergency instructions referred to in paragraph 3.2. Similarly, on ships of Classes other than the above

carrying passengers, if a muster of the passengers is not held on departure, their attention must be drawn to the emergency instructions referred to in paragraph 3.2. This can be done by means of a broadcast on the ship's public address system or by direct oral announcement.

5.4 It should be drawn to the attention of the passengers that the general emergency alarm signal is for the purpose of summoning them to their assembly or muster station (as appropriate) stations and is not a signal to abandon ship. The means by which the order to abandon ship will be given should be explained. The importance of being properly clad, of proceeding to their assembly or muster station (as appropriate) station in an orderly fashion, and of following instructions at all times should be emphasised. Where appropriate they should be advised to which type of survival craft they have been allocated, and how they will be embarked. They should be advised that only as a last resort will it be necessary to jump into the water. They should be informed of the dangers of jumping overboard, particularly from heights in excess of 6 metres and advised that if it should be necessary to jump into the water, the lifejacket must be held down with one hand and the nose protected with the other hand.

5.5 Lifejackets should be worn by passengers and crew when attending musters and drills. Crew members taking part in fire and other emergency drills may remove their lifejackets if these would be a hindrance in the execution of their duties. Where lifejackets are removed, a member of the emergency party concerned should be appointed to be responsible for these lifejackets and to ensure that they will be available for return to the members of an emergency party on completion of their relevant tasks. Where inherently buoyant lifejackets unduly hinder crew members in the execution of their duties, consideration should be given to the provision of inflatable lifejackets, although such lifejackets are not always suitable for use by members of fire hose parties due to the possibility of inadvertent activation of the automatic inflation system. Lifejackets should always be worn by members of survival craft preparation parties and at survival craft musters and drills.

5.6 On passenger ships consideration should be given to the identification of crew members, particularly those whose duties are concerned

with passenger control. This can be achieved in a variety of ways, eg by the use of headgear, distinctive marking on lifejackets, loose covers worn over lifejackets, armbands, etc.

5.7 On passenger ships as many key persons as possible should carry two-way portable radios during musters and drills and such radios and any fixed two-way communication systems should be used for communications between the bridge, emergency control stations, assembly or muster station (as appropriate) and embarkation stations, especially internal Marine Evacuation System (MES) embarkation stations. Where key persons do not have a two-way portable radio on permanent issue there should be arrangements whereby radios can be readily obtained at the outset of a drill or actual emergency. Where portable loud hailers are carried these should be used where appropriate for communicating or for simulating communicating with passengers at assembly or muster station (as appropriate) and embarkation stations. The arrangements for communication should be as recorded in muster lists and, where applicable, training manuals.

## **6 Abandon Ship Drills**

6.1 The commencement of an abandon ship drill is announced by the general emergency alarm signal. Crew and passengers, if any, should proceed to their assembly or muster station (as appropriate) stations. Crew members allocated to the handling of passengers should as appropriate clear or simulate the clearing of accommodation not used for the mustering of passengers, marshal passengers taking part in the drill and control the flow of passengers on the stairways, in passages and doorways and guide them towards their assembly or muster station (as appropriate) stations. At the assembly or muster station (as appropriate) stations they should ensure that passengers have donned their lifejackets correctly, or give instruction in donning as appropriate, and that child lifejackets are allocated to persons of less than 32 Kg. Passengers should be advised on the matters referred to in paragraph 5.4. Where a proportion of the survival craft consists of throwover liferafts boarded by means of ship's side ladders provision should be made for allocating only able bodied passengers to these liferafts. It should also be determined that crew members know how the order to abandon ship will be announced, that they are suitably dressed and that their lifejackets have been donned correctly.

## 7 Fire and other Emergency Drills

7.1 A fire or other emergency drill shall as far as practicable be conducted as if it were an actual emergency.

7.2 A fire or other emergency drill should be held simultaneously with the first stage of the abandon ship drill.

7.3 For the purpose of a fire drill an outbreak of fire should be assumed to have occurred in some part of the ship and fire control measures simulated as appropriate. The complete co-operation of the personnel of all departments is essential in fire fighting. The type and position of the supposed fire should be varied from time to time and can include:

- (1) Cargo fires in holds or other spaces;
- (2) Fires involving oil, gas or chemical cargoes as appropriate;
- (3) Fires in engine, pump or boiler rooms;
- (4) Fires in crew or passenger accommodation; and
- (5) Fires in galleys due to burning oil or cooking fats.

7.4 The engine room staff should ensure that the fire pumps in the machinery spaces are prepared for operation, started, and that full water pressure is on the fire mains. Where there is an emergency fire pump situated outside the machinery space, this pump should be started up as indicated below. The fire party or parties at the scene of the assumed fire should lay out hoses and where practicable water should be played through them, the water being supplied first from the machinery space pump and then from the emergency pump only, with the machinery space isolating valve closed. A number of portable fire extinguishers should be available and members of the fire party should be instructed in the use of the type of fire extinguisher for a particular type of fire.

7.5 The crew should be exercised as appropriate in the closing of openings, ie side scuttles, deadlights, doors, ventilating shafts, fire doors, the annular space around the funnel, etc both to reduce the supply of air to a fire and

isolate it from other parts of the ship, especially stairways and lift shafts. As many of the crew as possible and particularly the officers should be made familiar with the position of remote controls for ventilation fans, oil fuel pumps and oil tank valves and be instructed in the method of operation thereof.

7.6 Fixed installations for extinguishing fire, such as Halon, CO<sub>2</sub>, foam, or water spray in the machinery spaces, CO<sub>2</sub>, inert gas, steam or drencher systems in the cargo spaces, and sprinkler systems in passenger accommodation together with fire alarm and detection systems should be tested with as much realism as practicable. The fire party should also be exercised in the use of the breathing apparatus and protective clothing and such emergency appliances as axes and safety lamps, which should be brought out, checked and deployed by appointed members of the party at all fire drills. Where the number of sets of breathing apparatus permits, it is recommended that persons using them should practice in pairs.

7.7 It is important that members of the crew who are not allocated to fire parties are familiar with the use of and can identify the types of fire extinguisher they will encounter in the accommodation and in their work areas. Such crew members should be instructed in the use of the type of extinguisher appropriate to the kind of fire, eg those discharging water, foam, dry powder, CO<sub>2</sub>, etc.

7.8 At each fire drill at least one extinguisher should be discharged by a different crew member in order that both crew members in fire parties and other crew members gain experience in using fire extinguishers. Crew members should also be familiar with the location and means of activating the fire alarms in the accommodation and in their working areas. It is also important that all crew members and particularly those whose place of work is in a machinery space are familiar with the escape routes from any part of the ship they are likely to be in when on or off duty. Such familiarity should enable escape to be made in darkness or through smoke and should include familiarity with the location and the means of opening any emergency escape windows or hatches.

7.9 All fire protection systems and appliances should at all times be in good order and available for immediate use during the voyage and in port. Compressed air bottles of breathing apparatus

and fire extinguishers should be refilled after any drill. Where refilling facilities are not available on board additional equipment may be carried to facilitate training. Discharged equipment should be clearly marked and stored for refilling when in port. Equipment dedicated for training purposes should be marked 'for training purposes only'.

7.10 Participation in fire drills may not necessarily imply direct involvement with fighting a fire and may include back-up to fire parties, being a member of the first aid party or controlling passengers at their assembly or muster station (as appropriate) stations while the fire fighting part of the drill is being undertaken. On the other hand, on cargo ships with small crews it will usually be necessary for every member of the crew to be familiar with all aspects of fire-fighting and the use of all the fire-fighting equipment provided on board the ship.

7.11 Instruction should cover fire prevention, particularly in galleys, machinery spaces, cargo compartments, pumprooms and accommodation spaces. On-board instruction in fire-fighting is supplementary to training available at firefighting courses ashore and is primarily concerned with the particular equipment available on board and the nature of on-board fire hazards.

7.12 To ensure the ready availability of fire protection systems and appliances periodic checks should be performed. The following checklist may be used as guidance for this purpose.

7.12.1 Monthly testing and inspection should be carried out to ensure that:

- (1) all firemans outfits, fire extinguishers, fire hydrants, hose and nozzles are in place and in serviceable condition;
- (2) all escape routes including stairways and corridors are free of obstructions and properly maintained;
- (3) public address system and ship's alarms are serviceable;
- (4) all fixed fire fighting installation valves are set in the correct operational position;
- (5) dry pipe sprinkler systems are pressurised, where appropriate, and gauges indicate correctly;

(6) sprinkler system pressure tank water levels are correct as indicated by glass gauges;

(7) all sprinkler system pumps operate automatically on pressure loss in the systems;

(8) all fire pumps are operational; and

(9) all fixed gas fire extinguishing installations are free from leakage.

7.12.2 Quarterly testing and inspection should be carried out to ensure that:

(1) all fire extinguishers are at correct pressure and are not due for servicing;

(2) all automatic alarms for sprinkler systems activate using the section test valves;

(3) the international shore connection is serviceable;

(4) fire fighting equipment lockers contain their full inventory and the equipment they contain is in serviceable condition; and

(5) all fire doors, fire dampers and closing devices can be operated locally.

7.12.3 Annual testing and inspection should be carried out to ensure that:

(1) all fire doors, and ventilation dampers where appropriate, operate remotely;

(2) where practicable all aqueous foam and water spray fixed fire fighting installations operate correctly;

(3) all accessible components of fixed fire fighting systems, typically nozzles, are free from damage or obstruction on visual inspection;

(4) all fire pumps, including sprinkler system pumps, develop correct pressures and flow rates;

(5) all hydrants operate;

(6) all antifreeze solutions are correctly maintained and cross connection between

fire main and sprinkler system operates correctly; and

(7) fixed fire detection systems operate correctly, according to manufacturers test instructions.

7.13 Fire or other emergency drills should be followed by the second stage of the abandon ship drill ie the muster and drill at the survival craft stations. This stage of the abandon ship drill should be announced by the abandon ship signal or by the particular means by which abandon ship is announced, or by a signal used for the purpose of summoning crew members to their survival craft stations.

## **8 Drills in Closing of Doors, Side Scuttles and Other Openings**

8.1 In passenger ships, drills for practicing the closing of watertight doors, deadlights, scuppers, ash-shutes, rubbish-shutes and other similar devices are required to be carried out to comply with the Merchant Shipping (Passenger Ship Construction: Ships of Classes I, II, and II(A)) Regulations 1998, or the Merchant Shipping (Passenger Ship Construction: Ships of Classes III to VI(A)) Regulations 1998. These Regulations also require inspections, at intervals of not more than 7 days, of watertight doors and mechanisms, indicators and warning devices connected with such doors, valves, the closing of which is necessary to make watertight any compartment below the margin line, and valves, the operation of which is necessary for the efficient operation of damage-control cross-connections.

8.2 In all seagoing ships, with certain exceptions, the Merchant Shipping (Musters Training and Decision Support Systems) Regulations 1999 require practice fire drills to include checking of the operation of watertight doors, in the drill area.

8.3 Masters should familiarise themselves with the Regulations referred to in paragraphs 8.1 and 8.2, particularly in regard to the instruction of crew members in the safe operation of watertight doors and to those watertight doors, side scuttles, deadlights and other devices required to be securely closed before the ship proceeds to sea and to be kept securely closed while the ship is at sea.

Account should also be taken of the contents of Merchant Shipping Notice M.1326 (to be replaced

by MGN 35 (M)) on the dangers associated with power operated watertight doors, and of the Instructions for the Guidance of Surveyors (Passenger Ship Construction Classes I, II and II(A)) and (Passenger Ship Construction Classes III to VIA).

## **9 Survival Craft Muster and Drill**

9.1 Crew members other than those who cannot be relieved from their normal duties should muster, wearing lifejackets, at their lifeboat and liferaft stations. The person in charge of each survival craft must have a list of its crew and ensure that they are fully acquainted with their duties. The second-in-command of a lifeboat must also have a list of the lifeboat crew.

9.1.1 On passenger ships, the lifeboats used in the drill should where practicable, include some from each side of the ship and should be distributed as to enable the crews of the other lifeboats to watch the operations. Different groups of lifeboats should be used at successive drills.

9.1.2 In cargo ships provided with totally enclosed lifeboats which are boarded and launched from the stowed position, drills should periodically include the boarding of a lifeboat in its stowed position in order that crew members can become practiced in boarding a boat rapidly, locating a seating position and using the seat belts.

9.1.3 In the case of other totally enclosed lifeboats equipped with seatbelts, crew members should be periodically drilled in using the seatbelts but such lifeboats should not be boarded at the stowed position by the full complement at any one time. When a drill is being carried out inside a totally enclosed lifeboat, crew members should also be made familiar with the launching procedures and made aware of what to expect when the engine and air support and water spray systems, where fitted, are in operation.

9.1.4 Arrangements should always be made to ensure that those crew members who cannot be relieved from their duties to attend a particular drill can be relieved to attend the next drill.

9.2 On passenger ships when the drill is held at sea, a number of lifeboats should, if weather and other circumstances permit and subject to overriding safety constraints, be cleared, swung out, and lowered to embarkation deck level in the case of lifeboats boarded at this position, and side ladders and embarkation arrangements prepared. On cargo ships at least one lifeboat should be lowered when weather and other circumstances permit.

9.3 Each lifeboat and rescue boat engine must be tested by being run ahead and astern for a total period of not less than 3 minutes provided that the engine can be safely run for this period when out of the water and the ambient temperature is above the minimum required for starting the engine. Where lifeboats are fitted with mechanical hand-propelling gear, this gear should be examined and tested ahead and astern.

9.4 Liferaft davits must be swung out and winches operated.

9.5 Emergency lighting for mustering and abandonment must be tested at each such drill.

9.6 In cargo ships provided with lifeboats and throwover liferafts some drills should include preparation for abandonment involving use of liferafts in conjunction with lifeboats. This may include mustering at locations other than those used for embarkation into lifeboats

## **10 Survival Craft Drills Held in Port**

10.1 When a drill is held in port as many as possible of the lifeboats should be cleared, swung out and lowered. Each lifeboat must be launched with its assigned operating crew aboard and manoeuvred in the water once every 3 months during an abandon ship drill. In lifeboats not fitted with engines the crew should be exercised in rowing or in the use of the mechanical hand-propelling gear. Every opportunity should be taken to test the lifeboat disengaging gear where fitted.

10.2 If the berthing arrangements in port and the trading patterns of ships of Classes II, II(A), VIII or VIII(A) make the launching of lifeboats on one side impracticable then launching of lifeboats on that side at 3 monthly intervals need not be carried out. However all such lifeboats must be lowered at least once every 3 months and launched at least annually.

10.3 The launching of lifeboats and rescue boats should normally take place when the ship is alongside or at anchor with little or no tide or current, but if contemplated in circumstances where there is actual or effective headway, such launching must be carried out in accordance with the guidelines in the Annex to Merchant Shipping Notice M. 1218. (to be replaced by MSN 1722 (M + F).

10.4 A free-fall lifeboat may be lowered to the water if launching is impracticable, provided that free-fall launching with the assigned operating crew and manoeuvring in the water is carried out at least once every six months. If it is impracticable to launch within a period of six months, the Owners may apply to the MCA for an extension to twelve months.

## **11 Rescue Boat and Emergency Boat Drills**

11.1 As far as is reasonable and practicable rescue boats where carried, other than those which are also lifeboats, must be launched each month with their rescue boat crews and manoeuvred in the water. The interval between such drills must not exceed 3 months. Where climatic conditions permit, the crew of a rescue boat should wear their immersion suits during such in-water drills. Where possible such drills should include the recovery of an object simulating a person in the water. Emergency boats carried on passenger ships which do not carry rescue boats should be launched at similar intervals and should carry out similar drill procedures.

11.2 In ships of Class I the crews of rescue and emergency boats should be mustered on the first day of the voyage as soon as possible after sailing. The crews should be fully instructed and drilled in their duties and thereafter should be mustered and similarly drilled at intervals of not more than 7 days. Crews should be specifically instructed in the procedure of sending boats away promptly in an emergency and in recovering boats in a seaway, and should be familiar with the signal for mustering at the rescue or emergency boat station.

## **12 Davit-launched Liferaft On-Board Training**

12.1 On-board training in the use of davit-launched liferafts must take place at intervals of not more than 4 months on every ship fitted with such liferafts. Whenever practicable this training

includes the inflation and lowering of a liferaft. This liferaft may be a special liferaft intended for training purposes only or an old liferaft retained for training and not part of the ship's life-saving equipment. A special liferaft intended for training purposes only is required to be conspicuously marked and, if intended to be used for boarding when swung out at the embarkation deck, should be serviced at the same intervals as the liferafts forming part of the ship's life-saving equipment.

12.2 In preparing an on-board training programme for davit-launched liferafts the procedures adopted should take full account of the structural arrangements in way of the launching positions. For example it may not be possible to recover an inflated liferaft from an overside position without subjecting it to the risk of damage. Where procedures described in paragraphs 12.3 and 12.5 cannot be safely followed, other arrangements should be made which will enable on-board training of an equivalent standard to be carried out.

12.3 In ships of Classes II and II(A) on regular voyages, the four monthly on-board training in the use of davit-launched liferafts should include an inflation of one of the ship's liferafts. These inflations should take place when in port and where practical the liferaft should be lowered unloaded onto the quay rather than into the water. Training in boarding and using the release hook can be carried out when the liferaft is suspended just clear of the quay. The liferaft should be landed on a tarpaulin or heavy Polythene sheet to prevent any damage to the bottom of the raft. If it is not practical to land the liferaft on the quay, the boarding and use of the release hook can be carried out with the liferaft suspended just clear of the embarkation deck following initial inflation in the overside position. In this case the liferaft need not be lowered over the side but a weight should be attached to the release hook and then lowered to exercise the winch and give crew members practice in the handling of the winch and fall.

12.4 After this training the liferaft used should be sent for servicing. It is recommended that different liferafts be used at successive drills in order to avoid wear on a small number of liferafts.

12.5 In cargo ships and in passenger ships on irregular voyages, eg Class I cruise ships, there should be an inflation of one of the ship's liferafts at one of the four monthly on-board training

sessions in the use of davit-launched liferafts. The training should be carried out as described in paragraph 12.3 and the liferaft serviced as soon as possible after use. On the other two occasions in the twelve month period when the four monthly on-board training is carried out, this can be done using, for example, a practice raft and practice container. If such training is carried out in port, then the procedure described in paragraph 12.3 should be followed. If such training is carried out at sea, means should be provided for suspending and lowering the raft over a deck to provide the opportunity for boarding and handling the release hook.

12.6 Alternatively the procedure for ships engaged on regular voyages can be followed if this is more convenient.

### **13 On-board Instruction, Training and Training Manuals**

13.1 Before being assigned to shipboard duties, all persons employed or engaged on a seagoing ship other than passengers, shall receive appropriate familiarisation training in compliance with Reg VI/1 of the STCW95 Convention. This training is in addition to other shore based training required under the STCW95 Convention. Where thermal protective aids are carried every crew member should be trained in donning the aid while wearing a lifejacket. Crew members who have been allocated an immersion suit should be trained in the donning of the suit and given the opportunity to familiarise themselves with the wearing of the suit.

13.2 Crew members whose emergency duties include the guidance of passengers, and the searching and closing down of passenger spaces should be trained and instructed in these duties. Such training and instruction should cover the matters referred to in 6.1 above, in MGN 5, and should include the use of procedures for reducing or avoiding panic and the giving of clear reassuring orders. The training should be given prior to being assigned such duties on Ro-Ro passenger ships and other passenger ships.

13.3 Crew members allocated specific key tasks for the preparation, launching and handling of lifeboats, rescue boats, liferafts and marine evacuation systems should be trained in these specific tasks. Such training should also be given to a sufficient number of crew members to provide substitutes for the crew members allocated these key tasks in the muster list. The importance of

training, particularly in the handling of totally enclosed and partially enclosed motor propelled lifeboats fitted with onload release gear and in certain cases with self-contained air support and water spray systems, cannot be emphasised enough due to the complexity of such equipment. Training given on board is primarily concerned with the particular life-saving equipment carried and is supplementary to shore based training given on personal survival techniques, on proficiency in survival craft and rescue boat, and training-courses organised by individual owners. The training should include ship specific practices such as the normal sequence for preparing and safely deploying evacuation systems, launching lifeboats and liferafts, and all other factors which determine rate of evacuation, and may also cover alternatives to the normal sequence of deployment.

13.4 Where on-board training cannot be given in the use of certain items of life-saving equipment because of practical considerations, on-board instructions in the use of such equipment is required to be given at the same intervals as the drills. Instructions are required to be given in survival procedures including the causes of and first aid treatment for hypothermia, and first aid measures likely to be practiced in a survival craft. Instructions include the operation and use of the ship's liferafts and embarkation arrangements and the use of survival craft and rescue boats in severe weather and sea conditions. Instructions may also include actions to be taken in the event of foreseeable equipment failures.

13.5 The basic information on which these instructions will be based will be found in the ship's life-saving appliances training manual which contains instructions and information on the life-saving appliances carried, personal protective equipment and its location, in addition to information and instructions on survival, hazards of exposure, methods of retrieval and emergency repair of life-saving appliances. Any part of the information to be included in the Training Manual may be provided in the form of audio-visual aids. Information provided in lifesaving appliances training manuals should be compatible with, and may reproduce, relevant shipboard safety emergency plans which are required to be provided in accordance with the International Safety Management Code (SOLAS 1974 Chapter IX; reference should also be made to MSC/Circ.760 "Guidelines for a Structure of an Integrated System of Contingency Planning for Shipboard Emergencies."). (See paragraph 15.6)

13.6 The training manual can be used by the officer or officers whose duty it is to give the relevant instructions and it can also be used as a source of reference and information for every member of the crew. A copy of the training manual should be accessible to every crew member and except in certain ships of less than 500 GRT, a copy must be provided in each messroom and recreation room, or in each cabin.

13.7 In ships with significant numbers of non-English speaking crew members, copies of the full training manual or relevant sections should be provided in the appropriate language or languages.

13.8 The programme of instructions must be so arranged that every subject to be covered, including all parts of the ship's life-saving systems can be treated within a two month period. In order to carry out this programme in cargo ships, the frequency of holding drills may have to be increased beyond that necessary to ensure that every crew member participates in an abandon ship and fire drill every month. Frequent short periods of instruction dealing with a limited number of items will be more effective than long sessions dealing with a considerable amount of subject matter and held say at monthly intervals.

#### **14 Weekly and Monthly Inspection of LSA**

14.1 Weekly and monthly inspections as described in paragraph 14.2 and 14.3 must be carried out on all ships to which the Merchant Shipping (Life-Saving Appliances for Ships Other Than Ships of Classes III to VI(A)) Regulations 1999, and the Merchant Shipping (Life-saving Appliances for Passenger Ships of Classes III to VI(A)) Regulations 1999, apply.

14.2 At weekly intervals survival craft, rescue boats and launching appliances must be inspected to ensure that they are ready for immediate use. Rescue boat and lifeboat engines must be run at weekly intervals. The general emergency alarm system must also be tested every week.

14.3 All lifesaving appliances including lifeboat and rescue boat equipment is required to be inspected at monthly intervals. For this purpose the checklist provided in the instructions for onboard maintenance is used. This inspection should include the examination and testing of any fixed radio installations and searchlight equipment, and ensuring that the batteries can be charged from the dynamo when the engine is running.

14.4 In lifeboats with water spray systems, each system should be tested at intervals of not more than 3 months in accordance with the manufacturer's instructions. The system should be flushed through with fresh water after testing with sea water.

Regulations 1999, is not held a record must be made of the relevant circumstances and the extent of any muster, drill or training session held.

## **15 Decision Support System**

15.1 Passenger ships of Classes I, II and II(A) are required to have a decision support system for emergency management on the navigation bridge. It can be printed on paper, or computer based, and must identify all foreseeable emergency situations, establish emergency procedures for each situation, and provide decisive support to the Master.

15.2 Reference should be made to MSC/Circ.760 "Guidelines for a Structure of an Integrated System of Contingency Planning for Shipboard Emergencies".

15.3 The Guidelines noted above are intended to help integrate the various contingency Plans currently required by SOLAS and MARPOL, into a structured and consistent format. The Plans are required be in a uniform structure, be clear and easy to understand.

15.4 The Plans must be available in the working language of the Master, Officers and relevant crew members, and must be appropriately amended if the working language changes.

15.5 Training, drills, and records of such, of the Decision Support System, should be integrated into the overall training regime.

15.6 Copies of MSC/Circ.760 are available from the Marine Information Centre of the MCA:

Tel: 01703 329297

Fax: 01703 329298

## **16 Records**

16.1 The date on which musters, drills and training sessions are held, the type of drill and training held, and the occasions on which lifeboats, rescue boats and davit-launched liferafts, as applicable, are lowered or launched must be entered in the official log book.

16.2 Where a full muster, drill or training session as required by the Merchant Shipping (Musters Training and Decision Support Systems)

---

---

## Lifejackets carried on Passenger Ships

Guidance to Owners and Operators of Passenger Ships of Classes I, II and II(A), Masters, Officers, Ratings and Shipbuilders.

*This Note supersedes Merchant Shipping Notice No. M.1315*

---

---

### *Summary*

This Note advises all Owners and Operators of Passenger Ships of Classes I, II and II(A), Masters, Officers, Ratings and Shipbuilders of the correct method for stowage of lifejackets.

1. The statutory requirements for the stowage of lifejackets on passenger ships of Classes I, II and II(A) are contained in the Merchant Shipping (Life-Saving Appliances for Ships Other than Ships of Classes III to VI(A)) Regulations 1999. This Note recommends how these statutory requirements might be implemented.

#### **Stowage**

2. On Class I ships the recommended stowage position for lifejackets for both passengers and crew is in their respective cabins. Arrangements should always be made to ensure that child lifejackets are provided in cabins where small children are berthed. The additional 5 per cent lifejackets required to be provided on such ships should be stowed in lockers on deck preferably at the embarkation stations. Additional lifejackets for the use of the crew should be stowed on the bridge, in the engineroom control room and in any other working spaces where those on duty in these spaces would be unable to return to their cabins to collect their lifejackets in the event of an emergency.

3. On Class II and II(A) passenger ships with little or no passenger cabin accommodation, lifejackets for passengers should be stowed in or immediately adjacent to the assembly stations.

4. On Class II and II(A) passenger ships engaged on day and night sailings and with significant passenger cabin accommodation it is recommended that sufficient lifejackets be provided at the assembly stations for all the passengers and, in addition, sufficient lifejackets in the cabins for all the passengers for whom there is cabin accommodation. Alternatively, lifejackets should be provided at the assembly stations only.

5. The additional 5 per cent lifejackets required to be provided on such ships should be stowed in lockers on deck preferably at the embarkation stations. Lifejackets for the crew should be stowed in cabins and additional lifejackets should be stowed on the bridge, engine room control room and in any working spaces where those on duty in these spaces would be unable to return to their cabins to collect their lifejackets in the event of an emergency.

#### **Lifejacket lockers**

6. On passenger ships of Classes II and II(A) lifejackets which are stowed in or adjacent to assembly stations should be so stowed that for each assembly station there is at least one locker on each side of the ship. In a large assembly station there should be at least two lockers at each

end of the assembly station. This disposition of lockers ensures that except in the most unusual circumstances there should always be some of the lockers accessible at each assembly station. Dividing the stowage up in this way also permits a more rapid distribution of the lifejackets.

7. Child lifejackets should either be stowed in separate lockers or in lockers which have been internally subdivided.

8. Lockers should be clearly marked to indicate their contents, ie that they contain adult or child lifejackets, or both, and the number of each type as appropriate. A lifejacket donning notice for each type of lifejacket should be posted on the exterior and interior of the door unless a notice posted close to the door is not obscured when the door is open. Each locker should be identified by a number.

9. The securing arrangements on lifejacket locker doors should combine ease of access in an emergency, deterrence to unauthorised persons and some protection from inadvertent opening due to heavy rolling or an excessive list. Where doors are locked keys should be readily accessible in break glass boxes. Alternatively, the use of Customs seal wire, which should deter unauthorised opening of the locker, could be used to retain the door in its closed position and still allow it to be opened readily when required. It will also serve to indicate whether the door has been opened by unauthorised persons.

10. Where practicable, vertical doors should open in a forward or aft direction rather than athwartships. All lifejacket locker doors should be provided with means for holding them in the open position when lifejackets are being distributed.

11. Lockers should incorporate adequate ventilation and drainage facilities and lockers stowed on deck should be so located and designed to prevent the ingress of sea or rain water.

12. Care should be taken when stowing lifejackets that ceiling fittings such as sprinklers and lights are not obstructed. Consideration should be given to marking stowage heights on locker bulkheads.

## Identification of child lifejackets

13. Existing lifejackets which are marked "For persons of less than 32 kg" should be also marked with the word CHILD in letters at least 50 mm high. The manufacturer should be consulted to ensure that any ink or adhesive used is compatible with the lifejacket cover material or outer skin as appropriate.

MSPP2(C)  
Maritime and Coastguard Agency  
Spring Place  
105 Commercial Road  
SOUTHAMPTON SO15 1EG

Tel: 01703 329184  
Fax: 01703 329204

April 1999

MS 70/17/0004

© Crown Copyright 1999



*An executive agency of the Department of the  
Environment, Transport and the Regions*



Maritime and Coastguard Agency

AMENDMENT TO  
MARINE GUIDANCE NOTE

## MGN 77 (M+F)

---

---

### Instructions for Action in Survival Craft

*Guidance to Shipowners, Masters, Officers, Ratings, Manufacturers or Liferrafts and Lifeboat Builders.*

---

---

#### *Summary*

This Note advises all Shipowners, Masters, Officers, Ratings, Manufacturers of Liferrafts and Lifeboat Builders of the change in year of the Merchant Shipping (Life-Saving Appliances for Ships other than Ships of Class III to VI(A)) Regulations referred to in MGN 77.

1. Shipowners, Masters, Officers, Ratings, Manufacturers of Liferrafts and Lifeboat builders are advised that the reference made to the Merchant Shipping (Life-Saving Appliances for Ships other than Ships of Classes III to VI(A)) Regulations 1998 in MGN 77 should read Merchant Shipping (Life-Saving Appliances for Ships other than Ships of Classes III to VI(A)) Regulations 1999.

MSPP2c  
Maritime and Coastguard Agency  
Spring Place  
105 Commercial Road  
Southampton  
SO15 1EG

Phone: 01703 329184  
Fax: 01703 329204

December 1999

MS 011/049/0002



*An executive agency of the Department of the  
Environment, Transport and the Regions*





Maritime and Coastguard Agency

AMENDMENT TO  
MARINE GUIDANCE NOTE

## MGN 77 (M+F)

---

---

### Instructions for Action in Survival Craft

*Guidance to Shipowners, Masters, Officers, Ratings, Manufacturers or Liferrafts and Lifeboat Builders.*

---

---

#### *Summary*

This Note advises all Shipowners, Masters, Officers, Ratings, Manufacturers of Liferrafts and Lifeboat Builders of the change in year of the Merchant Shipping (Life-Saving Appliances for Ships other than Ships of Class III to VI(A)) Regulations referred to in MGN 77.

1. Shipowners, Masters, Officers, Ratings, Manufacturers of Liferrafts and Lifeboat builders are advised that the reference made to the Merchant Shipping (Life-Saving Appliances for Ships other than Ships of Classes III to VI(A)) Regulations 1998 in MGN 77 should read Merchant Shipping (Life-Saving Appliances for Ships other than Ships of Classes III to VI(A)) Regulations 1999.

MSPP2c  
Maritime and Coastguard Agency  
Spring Place  
105 Commercial Road  
Southampton  
SO15 1EG

Phone: 01703 329184  
Fax: 01703 329204

December 1999

MS 011/049/0002



*An executive agency of the Department of the  
Environment, Transport and the Regions*



## MGN 78 (M+F)

---

---

### Launching Crews for Lifeboats, Rescue Boats, Class C Boats, Inflatable Boats and Other Boats

---

---

Guidance to Shipowners, Masters, Officers and Seamen of Merchant Ships, and to Owners, Skippers, Mates and Crews of Fishing Vessels

*This Note supersedes Merchant Shipping Notice No. M. 1540*

---

---

#### Summary

This Note advises all Shipowners, Masters, Officers and Seamen of Merchant Ships, and Owners, Skippers, Mates and Crews of Fishing Vessels of the correct number of crew for launching lifeboats, rescue boats, Class C boats, inflatable boats and other boats for ships constructed before 1st July 1986.

1. The purpose of this Note is to supersede Merchant Shipping Notice No. M.1540 in accordance with the Merchant Shipping (Life-Saving Appliances for Ships Other than Ships of Classes III to VI(A)) Regulations 1999 and the Fishing Vessels (Safety Provisions) Rules 1975.

2. In a case where the boat or the means of launching is not of sufficient strength for the boat to be lowered safely into the water when loaded with its full complement of persons and equipment required by the Regulations and Rules the davits or other means of launching shall be conspicuously marked with a RED BAND 150 millimetres wide painted on a white background, in accordance with Regulations 28(19) and Rules 96(17) of the Merchant Shipping (Life-Saving Appliances for Ships Other than Ships of Classes III to VI(A)) Regulations 1999 and Fishing Vessels (Safety Provisions) Rules 1975, respectively.

3. The Maritime and Coastguard Agency considers that the proper number of men for a launching or recovery crew when the device is "RED-BANDED" is two. Shipowners, Masters, Officers and Seamen of merchant ships, and Owners, Skippers, Mates and Crews of fishing vessels are, therefore, asked to note that this number should never be exceeded.

4. A notice should be attached to each relevant set of davits or other device stating "Lower or recover with two man crew only".

5. In the case of a launch/recovery device for an inflatable boat, although in certain circumstances the boat is not required to be fitted with an engine, an allowance is made in all cases for the weight of an engine and its fuel of at least 60 kgs in case one is fitted at a later date.

6. **Note:** Under the Merchant Shipping (Life-Saving Appliances for Ships Other than Ships of Classes III to VI(A)) Regulations 1999 and the Merchant Shipping (Life-Saving Appliances for Passenger Ships of Classes III to VI(A)) Regulations 1999 Lifeboat Davits must be of sufficient strength to launch the boat and full complement. Rescue boat davits must be of sufficient strength to safely enable recovery of the rescue boat, its equipment and full complement of persons.

MSPP2(C)  
Maritime and Coastguard Agency  
Spring Place  
105 Commercial Road

SOUTHAMPTON SO15 1EG  
Tel: 01703 329184  
Fax: 01703 329204

August 1999  
MS 70/17/0004

# MGN 83 (M)

---

## Guidelines and Specifications for Hyperbaric Evacuation Systems

---

Guidance to Shipowners, Masters and Diving Contractors

*This Note supersedes Merchant Shipping Notice No. M.1450*

---

### Summary

This Note advises all Shipowners, Masters and Diving Contractors of the guidelines and specifications of hyperbaric evacuation systems to be provided for the evacuation of divers in saturation.

#### 1. Introduction

The Merchant Shipping (Life-Saving Appliances) Regulations 1998, require the provision of life-saving appliances for all sea-going personnel. Divers in saturation are not able to take advantage of conventional lifeboats in an emergency. The following guidelines and specifications shown in the attached Annex have therefore been developed. These guidelines were accepted by the Lifesaving Search and Rescue Sub-Committee at its 22nd Session and IMO Resolution A.692(17). Systems built before the implementation of IMO Resolution A.692(17) should comply with the requirements of this note.

They indicate the design and construction of hyperbaric evacuation systems to be provided for the evacuation of all divers in saturation and should provide a standard of safety for divers which, as far as is practicable, is equivalent to that required for other seagoing personnel. In addition compliance with these guidelines will satisfy Chapter 3 of the Code of Safety for Diving Systems, IMO Resolution A.536(13) as amended by Resolution A.583(14) in respect of United Kingdom ships.

#### 2. Hyperbaric Evacuation Methods

It is recognised that there are various methods available for evacuating divers in an emergency and that the suitability of the various options for a safe hyperbaric evacuation depend on a number of factors including the geographical area of operation, environmental conditions and any available offshore or onshore medical and support facilities. Options available to the diving contractor will include:

- .1 hyperbaric self propelled lifeboats;
- .2 towable hyperbaric evacuation units;
- .3 hyperbaric evacuation units which may or may not be towable suitable for off-loading onto an attendant vessel;
- .4 transfer of the diving bell to another facility;
- .5 transfer of the divers from one diving bell to another when in the water and under pressure; and

.6 negatively buoyant unit with inherent reserves of buoyancy, stability and life support capable of returning to the surface to await independent recovery.

The Guidelines and Specifications do not therefore attempt to specify which particular type of hyperbaric evacuation system should be employed and clients and diving contractors should examine and identify the option most suited for the area and type of operation in which they are engaged. Consideration may have to be given to the provision of separate evacuation facilities for divers in saturation at significantly different depths.

The concept of utilising the evacuation unit as a safe haven for divers who may have to be evacuated from the surface compression chamber should be considered in evaluating the various available options.

### **3. Contingency Planning and Emergency**

#### **Instructions**

A potentially dangerous situation can arise if a floating unit, from which saturation diving operations are being carried out, has to be abandoned with a diving team under pressure. While this hazard should be reduced by pre-planning, under extreme conditions consideration may have to be given to hyperbaric evacuation of the divers. The hyperbaric evacuation arrangements should be studied prior to the commencement of the dive operation and suitable written contingency plans made. Where, in the event of diver evacuation, decompression would take place in another surface compression chamber the compatibility of the mating devices should be considered.

Once the hyperbaric evacuation unit has been launched the divers and any support personnel may be in a precarious situation where recovery into another facility may not be possible and exposure to seasickness and accompanying dehydration will present further hazards. It is therefore necessary that diving contractors ensure that any such contingency plans include appropriate solutions. It should be emphasised that hasty or precipitous action may lead to a premature evacuation situation which could be more hazardous in the final analysis.

In preparing the contingency plans the various possible emergency situations should be identified taking into consideration the geographical area of operation, the environmental conditions, the proximity of other vessels, and the availability and suitability of any onshore or offshore facilities. The facilities for rescue, recovery and subsequent medical treatment of divers evacuated in such circumstances should be considered as part of the contingency plan. In the case of unattended hyperbaric evacuation units consideration should be given to providing equipment to transfer the tow line to an attendant vessel before launch of the hyperbaric evacuation unit. Such an arrangement would enable the unit to be towed clear immediately after launching. Copies of contingency plans shall be available on board the parent vessel, ashore and in the hyperbaric evacuation unit.

#### **4. Training and Evacuation Drill**

Periodic training exercises should be carried out to test the operation of the hyperbaric evacuation system and the efficiency of the personnel responsible for the hyperbaric evacuation of the divers. Such training exercises should not be carried out with divers under pressure in the hyperbaric chamber, but should be carried out at each available opportunity.

#### **5. Certification**

It is recognised that in the survey and testing of evacuation systems no one person may have all the necessary expertise and in certain circumstances it may be necessary for the owner to engage a competent person for particular tests and inspections. In ensuring that the system as a whole has been fully tested and before the Cargo Ship Safety Equipment Certificate can be endorsed, the Maritime and Coastguard Agency's surveyor should be provided with test and inspection certificates covering all the appropriate systems and equipment tested by other competent persons.

In so far as suitable "competent persons" are concerned reference should be made to:-

International Maritime Contractors Association  
235 Vauxhall Bridge Road  
London SW1V 1EJ

Tel: 0171 931 8171

MSAS(B)  
Maritime and Coastguard Agency  
Spring Place  
105 Commercial Road  
SOUTHAMPTON SO15 1EG

Tel: 01703 329112  
Fax: 01703 329161

September 1998

MS 70/17/004

© Crown Copyright 1998

***Safe Ships Clean Seas***

**ANNEX**

## **GUIDELINES AND SPECIFICATIONS FOR HYPERBARIC EVACUATION SYSTEMS**

### **1. Application**

The guidelines apply to hyperbaric evacuation systems provided on United Kingdom dive support vessels operating in the saturation mode and which are required by the provision of the Regulations to provide life-saving appliances for the total number of persons on board. In meeting the requirements in respect of divers, only one evacuation unit need be provided having a capacity to accommodate the total number of divers in saturation. However any existing system which complies with the provisions of these guidelines and specifications may be considered for endorsement of the Safety Equipment Certificate in accordance with Section 3.1.4.

### **2. Definitions**

For the purpose of these Guidelines and Specifications the terms used have the meanings defined in the following paragraphs unless expressly provided otherwise.

2.1 "Administration" means the Government of the State whose flag a ship or floating structure which carries a diving system, is entitled to fly or in which the ship or floating structure is registered.

2.2 "Bottle" means a pressure container for the storage and transport of gases under pressure.

2.3 "Breathing Mixture" means air or any other mixture of gases used for breathing during evacuation and, if applicable, during decompression.

2.4 "Depth" means the pressure, expressed in metres of seawater, to which the diver is exposed at any time during a dive or inside a surface compression chamber or a diving bell.

2.5 "Diving bell" means a submersible compression chamber, including its ancillary equipment, for transfer of divers under pressure between the work location and the surface compression chamber and vice versa.

2.6 "Diving system" means the whole plant and equipment necessary for the conduct of diving operations using transfer under pressure techniques.

2.7 "Hyperbaric evacuation system" means the whole plant and equipment necessary for the evacuation of divers in saturation from a surface compression chamber to a place where decompression can be carried out. The main components of a hyperbaric evacuation system include the hyperbaric evacuation unit, handling system and life support system.

2.8 "Hyperbaric evacuation unit" means a unit whereby divers under pressure can be safely evacuated from a ship or floating structure to a place where decompression can be carried out.

2.9 "Handling system" means the plant and equipment necessary for raising, lowering and transporting the hyperbaric evacuation unit from the surface compression chamber to the sea or onto the support vessel as the case may be.

2.10 "Hazardous areas" means those locations in which an explosive gas-air mixture is continuously present, or present for long periods (zone 0); in which an explosive gas-air mixture is likely to occur in normal operation (zone 1); in which an explosive gas-air mixture is not likely to occur, and if it does it will only exist for a short time (zone 2).

2.11 "Life support system" means the gas supplies, breathing gas system, decompression equipment, environmental control system, heating or cooling and other equipment required to provide a safe environment for the divers in the hyperbaric evacuation unit under all ranges of pressure that they may be exposed to during evacuation and, if applicable, during the decompression stages.

2.12 "Mating device" means the equipment necessary for connecting and disconnecting a hyperbaric evacuation unit to or from a surface compression chamber.

2.13 "Maximum operating depth" of the diving system is the depth in metres of seawater equivalent to the maximum pressure for which the diving system is designed to operate.

2.14 "Pressure vessel" means a container capable of withstanding an internal maximum working pressure greater than or equal to 1 bar.

2.15 "Compression chamber" means a pressure vessel designed for human occupancy with means of controlling the differential pressure between inside and outside of the chamber.

### **3. Surveys**

3.1 Each hyperbaric evacuation system should be subject to the following surveys, which are to be carried out by competent persons:

.1 An initial survey before being put into service. This should comprise a complete and thorough examination of the hyperbaric evacuation system, equipment, fittings, arrangements and materials including functional tests which should be such as to ensure they are suitable for the intended service and in compliance with these Guidelines and Specifications.

.2 A survey at intervals specified by the Administration but not exceeding 2 years.

.3 An annual inspection within 3 months of each anniversary date of the survey to ensure that the hyperbaric evacuation system, fittings, arrangements, safety equipment and other equipment remain in compliance with the applicable provisions of the Guidelines and Specifications and are in good working order.

.4 Where a hyperbaric evacuation system complies with the provisions, as applicable, of the Guidelines and Specifications and has been duly surveyed it may be recorded on the supplement to the Cargo Ship Safety Equipment Certificate and/or MSF 1102 Record of Inspection as providing the life-saving appliances and arrangements for divers in compression.

### **4. Design and Construction**

4.1 The design and construction of the hyperbaric evacuation system should be such that it is suitable for the environmental conditions envisaged, account being taken of the dynamic, snatch, horizontal or vertical loads that may be imposed on the system and its lifting points particularly during evacuation and recovery.

4.2 The hyperbaric evacuation unit should be capable of being recovered by a single point lifting arrangement and means should be provided on the unit to permit a surface swimmer or other person to hook on or connect the lifting arrangement.

4.3 In the design of pressure vessels including accessories such as doors, hinges, door landings, closing mechanisms, penetrators and viewports, the effect of rough handling should be considered in addition to design parameters such as pressure, temperature, vibration, operation and environmental conditions. In general, piping penetrations through the chamber should have isolating valves on both sides.

4.4 Materials used in the construction of hyperbaric evacuation systems should be suitable for their intended use.

4.5 Component parts of the hyperbaric evacuation system should be designed, constructed and tested in accordance with standards acceptable to the Administration.

4.6 Components in the hyperbaric evacuation system should be so designed, constructed and arranged as to permit easy inspection, maintenance, cleaning and, where appropriate, disinfection.

4.7 The hyperbaric evacuation system should be provided with the necessary control equipment to ensure its safe operation and the well being of the divers.

4.8 Special arrangements and instructions should be provided externally to enable the hyperbaric evacuation unit to be recovered safely. The instructions should be located where they will be legible when the hyperbaric evacuation unit is floating.

4.9 Hyperbaric evacuation systems should not be located in Zone 0 or Zone 1; hazardous areas and high fire risk areas should be avoided as far as is reasonably practicable.

## **5. Hyperbaric Evacuation Units**

5.1 The hyperbaric evacuation chamber is to be designed for the rescue of all divers in the diving system at the maximum operating depth. The compression chamber should provide a suitable environment and adequate facilities, including, where appropriate, seat belts, for the maximum number of persons for which the unit is designed. The seating or other arrangements provided should be designed to provide an adequate degree of protection to the divers from impact collisions during launch, while the unit is afloat and during recovery. Where the chamber is intended to be occupied for more than 12 hours arrangements for the collection or discharge of human waste should be provided. Where discharge arrangements are provided they shall be fitted with suitable interlocks.

5.2 The means provided for access into the compression chamber should be such as to allow safe access to or from the surface compression chambers. Interlocks should be provided to prevent the inadvertent release of the hyperbaric evacuation unit from the surface compression chamber whilst the access trunking is pressurised. The mating flange should be adequately protected from damage at all times, including during the launch and recovery stages.

5.3 Arrangements should be provided to enable an unconscious diver to be taken into the unit.

5.4 Compression chamber doors should be so designed as to prevent accidental opening while pressurised. All doors should be so designed that, where fitted, the locking mechanisms can be operated from both sides.

5.5 Arrangements should be provided to allow the occupants to be observed. If viewports are provided they should be situated so that risk of damage is minimised.

5.6 Where decompression of the divers after hyperbaric evacuation is intended to be carried out in another surface compression chamber, then consideration must be given to the suitability of the mating arrangements on that surface compression chamber. Where necessary a suitable adaptor and clamping arrangements should be provided.

5.7 A medical lock should be provided and be so designed as to prevent accidental opening while the compression chamber is pressurised. Where necessary, interlock arrangements should be provided for this purpose. The dimensions of the medical lock should be adequate to enable essential supplies, including CO<sub>2</sub> scrubber canisters, to be transferred into the compression chamber, and be of such dimensions as to minimise the loss of gas when the lock is being used.

## **6. Stability and Buoyancy**

6.1 Hyperbaric evacuation units designed to float should be provided with adequate stability for all conditions of operation and envisaged environmental conditions and be self-righting. In determining the degree of stability to be provided, consideration should be given to the adverse effects of large righting moments on the divers. Consideration

should also be given to the effect equipment and rescue personnel, required to be placed on the top of the system to carry out a recovery from the sea, may have on the stability of the hyperbaric evacuation unit.

6.2 Towing attachment points should be so situated that there is no likelihood of the hyperbaric evacuation unit being capsized as a result of the direction of the tow line. Where towing harnesses are provided they should be lightly clipped or secured to the unit and so far as is possible be free from snagging when pulled free.

6.3 Hyperbaric evacuation units designed to float should have sufficient reserves of buoyancy to enable the necessary rescue crew and equipment to be carried.

6.4 Where hyperbaric evacuation units are designed to be placed onboard a rescue vessel, the unit should be designed as to permit it to remain in an upright position and attachment points should be provided on the unit to enable it to be secured to the deck.

6.5 Hyperbaric evacuation units provided on ships required to have fire-protected lifeboats should have a similar degree of fire protection.

## **7. Life-Support System**

7.1 Means should be provided to maintain all the occupants in thermal balance and in a safe and breathable atmosphere throughout the environmental operational envelope for air temperature, sea temperature and humidity with the maximum and minimum number of divers likely to be carried. In determining the duration and amount of life-support necessary consideration should be given to the geographical and environmental conditions, the  $O_2$  and gas consumption and  $CO_2$  generation under such conditions, the heat input or removal and the emergency services that may be available for the decompression of the divers. Gas losses as a result of using toilet facilities which discharge to outside the hyperbaric evacuation unit and medical lock operation should be taken into account in determining the amount of gases required.

The effects of hypothermia and hyperthermia should be considered and the effectiveness of the arrangements provided should be established as far as is reasonable and practicable under all conditions envisaged. However in no such case should the duration of the unit's autonomous life-support endurance be less than 72 hours.

7.2 In addition to any controls and equipment fitted externally, compression chambers should be provided with adequate controls within for supplying and maintaining the appropriate breathing mixtures to the occupants, at any depth down to the maximum design operating depth. The persons operating the chamber, whether they are within or outside it, should be provided with adequate controls to provide life support. As far as practicable, the controls shall be capable of operation without a diver having to release his/her seat belt.

7.3 Two separate distribution systems should be provided for supplying oxygen to the compression chamber. Components in the system should be suitable for oxygen service.

7.4 Adequate equipment should be provided and suitably situated to maintain oxygen and carbon dioxide levels and thermal balance within acceptable limits for the life support duration.

7.5 In addition to any instrumentation necessary to be provided outside the compression chamber suitable instrumentation should be provided within the chamber for monitoring the partial pressures of oxygen and carbon dioxide and be capable of operation for the duration of the available life-support period.

7.6 Where it is intended that divers may be decompressed within the hyperbaric evacuation unit, provision should be made for the necessary equipment and gases including therapeutic mixtures, to enable the decompression process to be carried out safely.

7.7 An adequate supply of food and water should be provided within the evacuation chamber. In determining in particular the amount of water to be provided, consideration should be given to the area of operation and the environmental conditions envisaged.

7.8 A breathing system should be provided with masks which exhausts to the external environment sufficient for all the occupants under pressure.

7.9 Provision should be made external to the hyperbaric evacuation unit and in a readily accessible place for the connection of emergency hot or cold water and breathing therapeutic mixture. The dimensions of the connections provided should be as follows:

3/4 inch NPT (female)-Hot or cold water  
1/2 inch NPT (female)-Breathing mixture

The connections should be clearly and permanently marked and be suitably protected.

7.10 In hyperbaric evacuation units designed to pass through fires the breathing gas bottles and piping systems and other essential equipment should be adequately protected. In addition thermal insulation should be non-toxic and suitable for this purpose.

7.11 First Aid equipment, sickness bags, paper towels, waste disposal bags and all necessary operational instructions for equipment within the compression chamber should be available within the chamber, on board the parent vessel and ashore.

## **8. Fire Protection and Extinction**

8.1 Materials used in the construction and installation should so far as is possible be non-combustible and non-toxic.

8.2 A fire extinguishing system should be provided in the hyperbaric evacuation unit which should be suitable for exposure to all depths down to the maximum operating depth.

8.3 In hyperbaric evacuation units designed to float and which may be used to transport divers through fires, consideration should be given, where practicable, to providing an external water spray system for cooling purposes. (See paragraph 6.5.)

## **9. Electrical Arrangements**

9.1 All electrical equipment and installation, including the power supply arrangements, should be designed for the environment in which they will be required to be operated and designed to minimise the risk of electrical capacity depletion as result of fault, fire or explosion, electric shock, the emission of toxic gases and of galvanic action. Electrical equipment within the compression chamber should be designed for hyperbaric use, high humidity levels and marine application.

9.2 Power supplies required for the operation of life-support systems and other essential services should be sufficient for the life-support duration. The battery-charging arrangements should be designed to prevent overcharging under normal or fault conditions. The battery storage compartment should be provided with means to prevent over-pressurisation and any gas released should be vented to a safe place.

9.3 Each compression chamber should be provided with a source of lighting sufficient for the life-support time and be of such luminosity to allow the occupants to read gauges and operate essential systems within the chamber.

## **10. Launch and Recovery of Hyperbaric Evacuation Units**

Where appropriate:

10.1 Means should be provided for the safe and timely evacuation and recovery of the unit and due consideration should be given to the environmental and operating conditions, the dynamic, snatch and impact loadings that may

be encountered. Where appropriate the increased loading due to water entrainment should be considered. Where the primary means of launching depends on the ship's main power supply then a secondary and independent launching arrangement should be provided.

10.2 If the power to the handling system fails, brakes should be engaged automatically. The brake should be provided with manual means of release and control.

10.3 The launching arrangements provided should be designed to ensure easy connection or disconnection of the hyperbaric evacuation unit from the surface compression chamber and for the transportation and removal of the unit from the ship under the same conditions of trim and list as those for the ship's other survival craft.

10.4 Where a power actuated system is used for the connection or reconnection of the hyperbaric evacuation unit from the surface compression chamber then a manual or stored power means of connection or disconnection should also be provided.

10.5 The means provided for release of the falls or lift wire after the unit is afloat should provide for easy disconnection, particular attention being given to units not provided with an attendant crew.

10.6 Where the hyperbaric evacuation unit is designed to be recovered from the sea, or from a ship in a seaway, consideration should be given to the mode of recovery. Adequate equipment to enable a safe recovery of the unit should be provided on the unit.

Permanently marked clear instructions should be provided adjacent to the lifting equipment as to the correct method for recovery including the total weight of the hyperbaric evacuation unit. Consideration should be given to the effect which water entrained and any bilge water may have on the total weight to be lifted by the recovery vessel. Consideration should also be given to any means that can be provided for the absorption of the dynamic or snatch load imposed recovery of the hyperbaric evacuation unit from the sea.

## **11. Communications and Locating Systems**

11.1 If breathing mixtures containing helium or hydrogen are used, a self-contained primary communications system fitted with an unscrambler device should be arranged for direct two-way communication between the divers and those outside the compression chamber. A secondary communication system should also be provided.

11.2 In addition to the communication system referred to in 11.1 a standard bell emergency communication tapping code should be provided which meets the requirements of that specified in the Supplement to the IMO Code of Safety for Diving Systems-resolution A.583(14). Copies of the tapping code should be permanently displayed inside and outside the evacuation unit.

11.3 Hyperbaric evacuation units designed to be water borne should be provided with a strobe light and radar reflector.

11.4 Hyperbaric evacuation units designed to be placed on the seabed to await independent recovery should be provided with a strobe type light and an acoustic transponder. The transponder should be suitable for operation with a diver held interrogator-receiver which will be retained onboard the parent ship. The equipment provided should meet the requirements of that specified in the Supplement to the IMO Code of Safety for Diving System-resolution A.583(14).

## **12. Marking and Information to be Provided on Hyperbaric Evacuation Units**

12.1 Dedicated hyperbaric evacuation units should be coloured International orange and be provided with retro-reflective material to assist in their location during hours of darkness.

12.2 Each hyperbaric evacuation unit designed to be water borne should be marked with at least three identical signs as shown below. One of these markings should be on the top of the unit and clearly visible from the air and the other two, on either side, mounted vertically and as high as possible and capable of being seen while the unit is afloat.

12.3 Where applicable the following should be clearly visible and readily available whilst the unit is afloat.

- .1 Towing arrangements and buoyant tow line.
- .2 All external connections, particularly for the provision of emergency gas, hot/cold water and communications.
- .3 Maximum gross weight of unit in air.
- .4 Lifting points.
- .5 Name of the parent ship and port of registration.
- .6 Emergency contact telephone, telex and facsimile numbers.

#### 12.4 Warning Information

Where appropriate every hyperbaric evacuation unit should be permanently marked in two separate locations with the following information and these markings should be clearly visible while the unit is afloat.

“Unless Specialised Diving Assistance is available:

- .1 Do not touch any valves or other controls.
- .2 Do not try to get occupants out.
- .3 Do not connect any gas, air, water or other supplies.
- .4 Do not attempt to give food, drinks or medical supplies to the occupants.
- .5 Do not open any hatches”.

### **13. Maintenance and Testing**

The availability of any evacuation system provided is dependent on the regular testing and maintenance of the system. A planned maintenance and testing programme should be devised with the responsibility of carrying out the maintenance tasks being allocated to specific crew members. A maintenance and testing schedule should be available for recording the execution of the tasks and signatures of the persons allocated the tasks. Such schedules should be maintained onboard and be available for inspection.

[Diver Rescue Diagram]

---

---

## Guidelines and Specifications for Hyperbaric Evacuation Systems

*Guidance to Shipowners, Masters and Diving Contractors.*

---

---

### *Summary*

This Note advises all Shipowners, Masters and Diving Contractors of the change in year of the Merchant Shipping (Life-Saving Appliances for Ships Other Than Ships of Classes III to VI(A)) Regulations referred to in MGN 83.

1. Shipowners, Masters, and Diving Contractors are advised that the reference made to the Merchant Shipping (Life-Saving Appliances) Regulations 1998 in MGN 83 should read Merchant Shipping (Life-Saving Appliances for Ships Other Than Ships of Classes III to VI(A)) Regulations 1999.

MSPP2c  
Maritime and Coastguard Agency  
Spring Place  
105 Commercial Road  
Southampton  
SO15 1EG

Phone: 01703 329184  
Fax: 01703 329204

December 1999

MS 011/049/0001





Maritime and Coastguard Agency

---

---

## Use and Fitting of Retro-Reflective Material on Life-Saving Appliances

Notice to Owners of Merchant Ships and Fishing Vessels, Shipbuilders and Repairers, Manufacturers of Life-Saving Appliances, Masters, Skippers, Officers and Ratings

*This Note supersedes Merchant Shipping Notice No. M.1444*

---

---

### *Summary*

This Note advises of the requirements for fitting of retro-reflective material on certain life-saving appliances.

This Note forms an integral part of the Merchant Shipping (Life-Saving Appliances for Passenger Ships of Classes III to VI(A)) Regulations 1999 and the Merchant Shipping (Life-Saving Appliances for Ships other than Ships of Classes III to VI(A)) Regulations 1999.

1. The Merchant Shipping (Life-Saving Appliances for Passenger Ships of Classes III to VI(A)) Regulations 1999 and the Merchant Shipping (Life-Saving Appliances for Ships other than Ships of Classes III to VI(A)) Regulations 1999 require that life-saving appliances carried on ships to which the Regulations apply be fitted with retro-reflective material where this will assist in detection.
2. The International Maritime Organisation (IMO) has issued Resolution A.658(16) which contains guidelines on the use and fitting of retro-reflective material on life-saving appliances and these guidelines are incorporated in the Annex to this Notice.
3. Where the legislation referred to in paragraph 1 requires that the dimensions and location of the material be to the satisfaction of the Secretary of State, the dimensions and location described in the guidelines, or the nearest equivalent arrangement, will be acceptable for this purpose.
4. When retro-reflective material is being fitted on new or existing life-saving appliances, or being replaced on existing life-saving appliances, it should be fitted in accordance with the guidelines. Material to be used must be of a type which has been approved by, or on behalf of, the Agency as complying with IMO Resolution A.658(16) Annex 2 and overprinted with an approved reference code. All retro-reflective material that is cracked, delaminated or otherwise mechanically damaged must be replaced. A simplified visual performance test is outlined in paragraph 5 and incorporates advice given by a leading manufacturer of approved retro-reflective material.
5. The performance of the retro-reflective material fitted to life-saving appliances should be checked by the following method at regular intervals and when life-saving appliances are being serviced:
  - .1 Place a new piece of the same retro-reflective material adjacent to, and on the

same plane as, a representative piece of material fitted to the appliance.

- .2 Pour water over both pieces of material.
- .3 Using a powerful torch or Aldis lamp held at eye level, compare the performance of the two pieces of material from a distance of 10 metres.
- .4 If a noticeable deterioration in performance is observed then the retro-reflective material on the appliance should be replaced.
- .5 Dry off the appliance before re-stowing.

MSPP2  
Maritime and Coastguard Agency  
Spring Place  
105 Commercial Road  
SOUTHAMPTON SO15 1EG

Tel: 01703 329184  
Fax: 01703 329204

March 1999

MS 70/17/0004

© Crown Copyright 1999



*An executive agency of the Department of the  
Environment, Transport and the Regions*

## ANNEX

### GUIDELINES ON THE USE AND FITTING OF RETRO-REFLECTIVE MATERIALS ON LIFE-SAVING APPLIANCES

#### 1. Lifeboats and Rescue Boats

Retro-reflective materials should be fitted on top of the gunwale as well as on the outside of the boat as near the gunwale as possible. The materials should be sufficiently wide and long to give a minimum area of 150cm<sup>2</sup> and should be spaced at suitable intervals (approximately 80cm from centre to centre). If a canopy is fitted, it should not be allowed to obscure the materials fitted on the outside of the boat, and the top of the canopy should be fitted with retro-reflective materials similar to those mentioned above and spaced at suitable intervals (approximately 80cm centre to centre). In the case of partly enclosed or totally enclosed lifeboats, such materials should be placed as follows:

- .1 for detection by horizontal light beams - at suitable intervals at half the height between the gunwale and the top of the fixed cover; and
- .2 for detection by vertical light beams (eg from helicopters) - at suitable intervals around the outer portion of the horizontal (or comparable) part of the top of the fixed cover;
- .3 retro-reflective materials should also be fitted on the bottom of lifeboats and rescue boats which are not self-righting.

#### 2. Liferrafts

Retro-reflective materials should be fitted around the canopy of the liferaft. The material should be sufficiently wide and long to give a minimum area of 150cm<sup>2</sup> and should be spaced at suitable intervals (approximately 80cm from centre to centre) at a suitable height above the waterline, doorways included, if suitable. On inflatable liferafts, retro-reflective materials should also be fitted to the underside of the floor, cross-shaped in the centre. The dimension of the cross to be half the diameter of the liferaft, and a similar cross should be applied to the top of the canopy.

On liferafts which are not equipped with canopies, materials which should be sufficiently wide and long to give a minimum area of 150cm<sup>2</sup> should be attached to each buoyancy chamber at suitable intervals (approximately 80cm centre to centre) in such a manner that they are visible both from the air and from a ship.

#### 3. Lifebuoys

Retro-reflective materials of a sufficient width (approximately 5cm) should be applied around or on both sides of the body of the lifebuoy at four evenly-spaced points.

#### 4. Buoyant Apparatus

Buoyant apparatus should be fitted with retro-reflective materials in the same manner as liferafts without canopies, always depending on the size and shape of the object. Such materials should be visible both from the air and from a ship.

#### 5. Lifejackets

Lifejackets should be fitted with patches of retro-reflective materials with a total area of at least 400cm<sup>2</sup> distributed so as to be useful for search from air and surface craft from all directions. In the case of a reversible lifejacket, the arrangement should be complied with no matter which way the lifejacket is put on. Such material should be placed as high up on the lifejacket as possible.

#### 6. Immersion suits

Immersion suits should be fitted with patches of retro-reflective material with a total area of at least 400cm<sup>2</sup> distributed so as to be useful for search from air and surface craft from all directions.

For an immersion suit that does not automatically turn the wearer face up, the back of the suit should be fitted with retro-reflective material with a total area of at least 100cm<sup>2</sup>.

#### 7. General remarks

- .1 Retro-reflective materials should meet the minimum technical specification given in the Technical Specification for Retro-Reflective Material for use on Life-Saving Appliances (Annex 2 to resolution A.658(16)).
- .2 The illustrations reproduced in this annex are intended to provide Administrations with examples from which guidance may be taken when fitting retro-reflective materials in accordance with these guidelines.

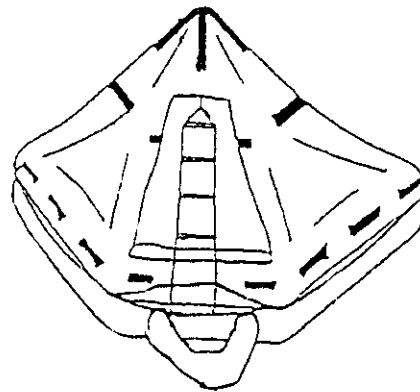
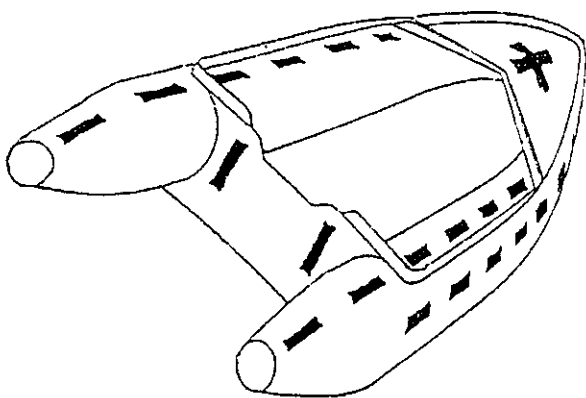
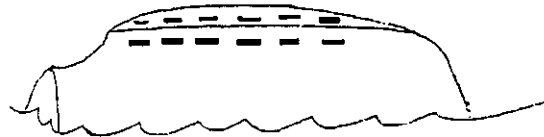
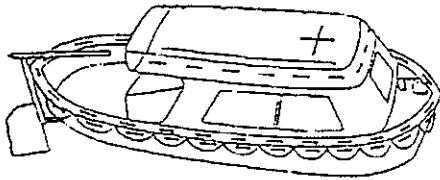
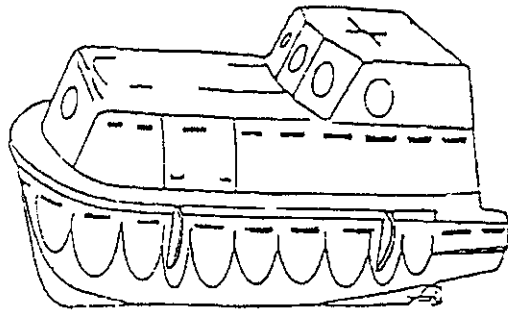
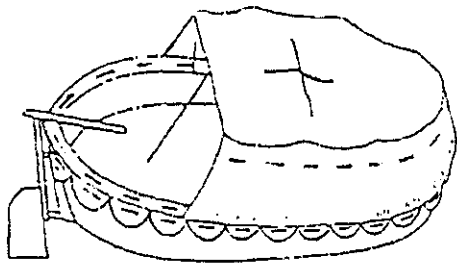

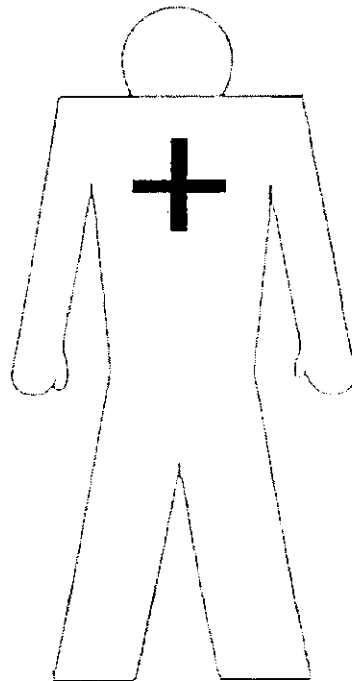
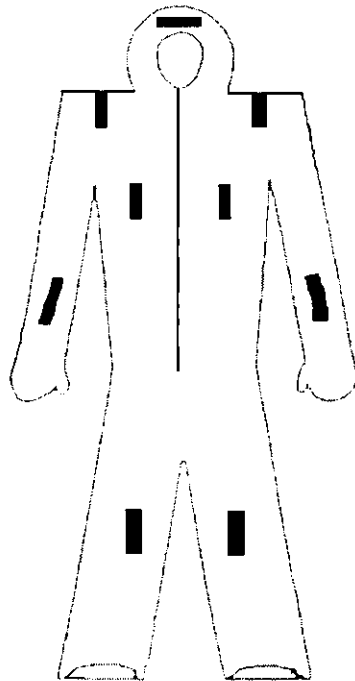
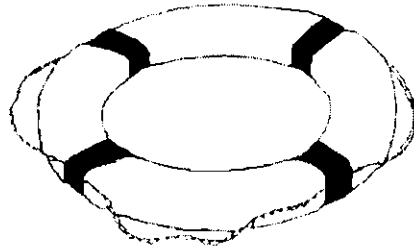
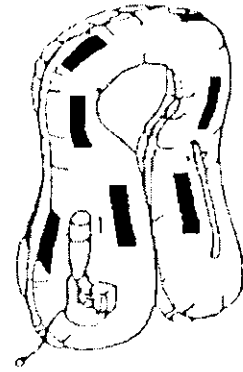
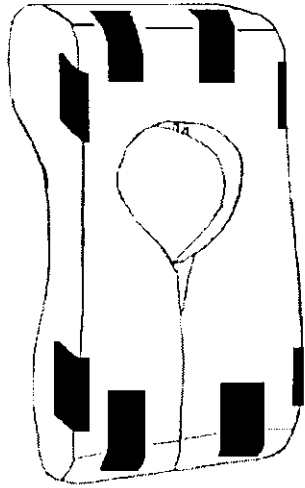



Maritime and Coastguard Agency

## MGN 106 (M+F)

---

---

# NATURAL & SYNTHETIC FIBRE CORDAGE FOR LIFE-SAVING APPLIANCES

Guidance to Shipowners, Masters, and Officers of Merchant Ships and Yachts; and to Owners, Skippers and Crews of Fishing Vessels

*This Note supersedes Merchant Shipping Notice No.M.1232*

---

---

### *Summary*

This Note advises all Shipowners, Masters, Officers and Seamen of required standards for natural and synthetic fibre (polypropylene, polyester, polyamide) rope for life-saving appliances (LSA).

- Types of rope acceptable to the Maritime and Coastguard Agency (MCA).
- Evidence from manufacturers' required prior to acceptance of the rope.
- Detailed characteristics given in the Annex.

1. Natural and synthetic fibre ropes intended for use with life-saving appliances should comply with the BSEN standards contained in Annex 1, which is acceptable to the Agency.

2. Before accepting a rope for use onboard, the master should sight a certificate of conformity for the rope. In addition, evidence showing that the rope is sufficiently protected and stabilized against UV degradation.

3. Responsibility for replacing worn, weathered or damaged cordage at all times lies with the master of the vessel.

4. The attached Annex 1 "Cordage for LSA Purposes" indicates the characteristics required of ropes for various life-saving appliance uses and the sizes considered appropriate. Unlike natural cordage the grip provided by different types of synthetic fibre ropes ranges between a grip comparable with manila or sisal to little grip at all. The type of synthetic fibre ropes must therefore be carefully chosen to meet differing grip requirements.

5. Guidance on inspection and care of synthetic fibre ropes in use is included in Annex 2 to this Note.

MSPP2  
Maritime and Coastguard Agency  
Spring Place  
105 Commercial Road  
SOUTHAMPTON  
SO15 1EG

Tel: 01703 329184  
Fax: 01703 329204

April 1999

MS 70/17/0004

© Crown Copyright 1999



*An executive agency of the Department of the Environment, Transport and the Regions*

## Annex 1

### CORDAGE FOR LIFE-SAVING APPLIANCES

Note: **M** denotes Manila rope, complying with BS EN 698: 1995-Fibre Ropes for General Service.

**S** denotes Sisal rope, complying with BS EN 698: 1995-Fibre Ropes for General Service.

**Pa** denotes Polyamide (nylon) rope, complying with BS EN 696: 1995-Fibre Ropes for General Service (Polyamide).

**Pe** denotes Polyester rope, complying with BS EN 697: 1995-Fibre Ropes for General Service (Polyester).

**Pp** denotes Polypropylene rope, complying with BS EN 699: 1995-Fibre Ropes for General Service (Polypropylene).

**All ropes to comply with the requirements of BS EN 701: 1995 – Fibre Ropes for General Service General Specification**

**Where polypropylene is suggested and the grip is required to be similar to that of manila, then only staplespun polypropylene is suitable.**

Application	Type	Grip	Minimum Size of Cordage Diameter in millimetres	
			M or S	Pa, Pe or Pp
Lifeboat and gunwale grablines	M S Pa Pe Pp	Not critical	16 mm	16 mm
Buoyant apparatus grablines	M S Pp	Not critical	14 mm	14 mm
Lifeboat keel grablines (should be knotted)	M S Pa Pe Pp	Not critical	16 mm	16 mm
Buoyant heaving lines	Cotton or Pp	As Manila	8 mm	8 mm
Lifeboat boarding ladders	M S Pa Pe Pp	As Manila	16 mm	16 mm
Overside ladders for lifeboat or liferaft embarkation	M Pa Pe Pp	As Manila	20 mm	20 mm
Lifebuoy grablines	M S Pp unkinkable	Not critical	10 mm	10 mm
Lifebuoy lines	Buoyant Cotton Pp	As Manila	8 mm	8 mm
Lifelines from davit spans	M Pe Pp	As Manila	20 mm	24 mm
Boats' painters	M S Pa Pe Pp boat under 8 m	As Manila	20 mm	24 mm
	8 m and under 9 m		24 mm	28 mm
	9 m boat and over		28 mm	32 mm
Buoyant apparatus painters	M S Pp	As Manila	16 mm	16 mm
			Mass less than 140kg	20 mm
Mass 140kg and over				

Application	Type	Grip	Minimum Size of Cordage Diameter in millimetres	
			M or S	Pa,Pe or Pp
Sea anchor for open lifeboats of 6 metres and under	M S Pa Pe Pp	As Manila	Hawser: 20 mm	20 mm
Open lifeboats over 6 metres			Tripping Line: 12 mm	12 mm
			Hawser: 24 mm	24 mm
			Tripping Line: 16 mm	16 mm
Open lifeboat Sails: Halyards, sheets and roping	M S Pe Pp	As Manila	As current practice	As for natural fibre cordage
Bowsing tackle	Pe Pp should be of Manila or Polypropylene of a type acceptable to the MCA and having a grip comparable with Manila; the type and size of tackle and size cordage should be as follows:			
Fully laden mass of boat Under 8 tonnes	Gun tackle (two single blocks)			20 mm
8 tonnes and under 10 tonnes	Gun tackle (two single blocks)			24 mm
10 tonnes and under 12 tonnes	Luff purchase (one double and single block)			18 mm
12 tonnes and under 15 tonnes	Two fold purchase (two double blocks)			20 mm
15 tonnes and under 20 tonnes	Three/two fold purchase (one treble and one double block)			20 mm
Boats' falls	Manila, durable, unkinkable, firm laid and pliable. Breaking load to be at least 6 x maximum load when hoisting and lowering. To be not less than 20 mm. To be able to pass freely a hole 10 mm larger than the nominal diameter of the rope. Man made fibre cordage is not generally accepted.			

## Annex 2

### THE INSPECTION AND CARE OF POLYAMIDE (NYLON), POLYESTER AND POLYPROPYLENE FILAMENT ROPES IN USE

#### GENERAL

Ropes made from any material are liable to wear and to mechanical damage, and can be weakened to some extent by various agencies such as chemicals, heat and light.

Regular inspection is essential to ensure that the ropes are still serviceable.

It is also emphasized that no matter what agent has weakened the rope the effect will be more serious on the small sizes than on the larger sizes of rope. Consideration should, therefore, be given to the relationship of the surface area of the rope and the rope cross section. Examinations of about 300 mm at a time may prove to be convenient, the rope being turned to reveal all sides before continuing. At the same intervals the strands should be untwisted slightly to allow examination between the strands.

To define a standard of acceptance or rejection is much more difficult than to describe the method of inspection. There can be no well defined boundary between ropes which are safe and those which are not because this depends on the stresses placed on a rope in an emergency. In practice, the decision whether to continue to use a rope or discard it should be based on an assessment of the general condition of the rope. Many of the conditions which will guide the examiner cannot be exactly described, but can only be stated in general terms.

If after examination, there is any doubt about the safety of the rope, it should be withdrawn from service. It is again emphasized that the effects of wear and mechanical damage are relatively greater on thinner ropes which, therefore, require more stringent standards of acceptance.

#### PHYSICAL CAUSES OF DAMAGE

##### General external wear

External wear due to dragging over rough surfaces causes surface chafing or filamentation. This is the most readily noticeable cause of weakness, particularly if a new rope is available for comparison. In the extreme, the strands become so worn that their outer faces are flattened and the outer yarns are severed. In ordinary use some disarrangement or breakage of the fibres on the outside of the rope is

unavoidable and harmless if not extensive. Polyamide (nylon), polyester and polypropylene filament ropes have a very good abrasion resistance.

##### Local abrasion

Local abrasion, as distinct from general wear, may be caused by the passage of the rope over sharp edges while under tension and may cause serious loss of strength. Slight damage to the outer fibres and an occasional torn yarn may be considered harmless but serious reduction in the cross-sectional area of one strand or somewhat less serious damage to more than one strand should merit rejection. Protection at points where excessive abrasion may occur should be considered.

##### Cuts, Contusions, etc.

Cuts, contusions, etc. or careless use may cause internal as well as external damage. This may be indicated by local rupturing or loosening of the yarns or strands.

##### Internal wear

Internal wear caused by repeated flexing of the rope, particularly when wet, and by particles of grit which have been picked up, may be indicated by excessive looseness of the strands and yarns or the presence of powdered fibre.

##### Repeated loading

The resistance of polyamide (nylon) or polypropylene filament rope to damage due to repeated loading is good but a permanent elongation may occur so that the extension available in an emergency is reduced.

If the original length of the rope is known exactly, a check measurement made under exactly the same conditions will indicate the total extension of the rope but may not reveal local extension of parts of the rope. Measurement of the distance between regularly spaced indelible markers on the rope may help to reveal severe local permanent elongation which may cause breakdown on subsequent loading.

#### EXTERNAL CAUSES OF DAMAGE

##### Heat

Heat may, in extreme cases, cause fusing. Any signs of this should obviously merit rejection, but a rope may be damaged by heat without any

such obvious warning. The best safeguard is proper care in use and storage. A rope should never be dried in front of a fire or stored near a stove or other source of heat.

Surging of a polypropylene or polyethylene rope under tension can cause sufficient frictional heat at the contact surfaces to result in the fusing of the surface of the rope. This can be minimized by not applying more turns of the rope around the winch, drum or capstan than are necessary to obtain satisfactory hauling.

The number of turns required around a winch will vary to some extent according to operating conditions and may be different for each of the different types of polypropylene rope. The melting point of polypropylene is 160°C to 170°C while the softening point is around 150°C. The values for polyethylene are somewhat lower. These temperatures are quite quickly produced when a rope is surged on a winch or capstan.

#### **Mildew**

Mildew does not attack polyamide (nylon), polyester and polypropylene ropes.

#### **Strong sunlight**

Strong sunlight causes weakening of rope fibres, but is unlikely to penetrate beneath the surface. Unnecessary exposure should be avoided.

Solar degradation should be checked by rubbing the surface of the rope with the thumb nail. If degradation has taken place the surface material will come off as powder.

In addition, the surface of the rope will feel dry, harsh and resinous.

### **CHEMICAL CAUSES OF DAMAGE**

#### **General**

The variety of possible chemical contaminants of rope is very wide and the information given in above is only a general guide. In cases of uncertainty on the nature of the contaminant and the remedy to be adopted an expert should be consulted. Attack may be more severe if some drying out occurs.

#### **Polyamide (nylon) ropes**

Chemical attack of a sufficient degree may be indicated by local weakening or softening of the rope so that surface fibres can be plucked or rubbed off as a powder in extreme cases. The chemical resistance of polyamide (nylon) filament is in general extremely good, but solutions of

mineral acids cause rapid weakening. It is advisable, therefore, to avoid immersion in acid solutions, either cold or hot.

Polyamide (nylon) filament is unaffected by alkalis at normal temperatures and by many oils although it swells in contact with certain organic solvents. Exposure to fumes, spray or mist of acids or to organic solvents should be avoided, but if contamination is suspected, the rope should be washed out well in cold water. If there is any doubt after subsequent careful inspection, the rope should be discarded.

Polyamide (nylon) ropes absorb a limited amount of water when wetted and may lose a small proportion of their strength while wet.

#### **Polyester ropes**

Chemical attack of a sufficient degree may be indicated by local weakening or softening of the rope so that surface fibres can be plucked or rubbed off as a powder in extreme cases. The chemical resistance of polyester filament is generally extremely good, but hot solutions of strong alkalis progressively dissolve the fibre, causing gradual loss in mass and a corresponding fall in breaking load. It is advisable, therefore, to avoid exposure to alkaline conditions. Resistance to acids and particularly to sulphuric acid is good, although the concentration should not be allowed to exceed about 80%.

Thus, even dilute solutions of sulphuric acid should not be allowed to dry on a rope. If any contamination is suspected, the rope should be washed out well in cold water. If there is any doubt after subsequent careful inspection, the rope should be discarded.

Resistance to hydrocarbon oils and common organic solvents is good, although polyester filament may swell in certain chlorinated solvents. Attack by concentrated phenols is severe and contact should be avoided.

#### **Polypropylene ropes**

Polypropylene ropes are unaffected at normal temperatures by acid or alkalis but are attacked by some organic solvents such as white spirit, xylene and meta-cresol.

Rope contact with wet paint, coal tar or paint stripping preparations should be avoided.



Maritime and Coastguard Agency

## MGN 127 (M+F)

---

---

# Means of Recovering Casualties From the Sea When Involved in Ship to Ship Personnel Transfers

Notice to Owners, Operators and Masters of Merchant Ships, Tugs and Owners and Skippers of Fishing Vessels, Owners and Operators of Code of Practice Vessels and Yachtsmen

---

---

### *Summary*

The purpose of this Note is to recommend that all vessels engaged in ship to ship personnel transfers whilst both vessels are in motion, carry equipment designed to aid in the rapid recovery of a casualty from the water.

There have been a number of accidents, some fatal, whilst transferring personnel between vessels making way. A fatal accident occurred in the River Humber in December 1997 when a Mooring Assistant fell, after losing his footing and grip on a ladder, whilst transferring between a tug and a tanker. His eventual recovery took ten minutes but by then he was unconscious due to hypothermia. He was taken by helicopter to hospital but died an hour later.

The key lessons to be learnt from incidents such as this, are that strict operational procedures must be followed, particularly in cold, wet and adverse sea conditions. These will assist in preventing accidents and ensure a rapid recovery from the sea in the event that they occur.

A detailed assessment of retrieval equipment available for use on all small vessels should be carried out as soon as possible. Small tugs and similar vessels with less than four or five persons in the crew may be exempted from carrying a rescue boat, where it is not practicable to operate one. The exemption is conditional on the following:-

- the adequate manoeuvrability of the vessel;
- the provision of an overside ladder;
- the provision of some means to recover an unconscious person; and

- the crew being trained and practised in man overboard procedures.

Any vessel acting as its own rescue boat must demonstrate to the MCA surveyor issuing the certification the practical effectiveness of its retrieval system, as follows:-

- a suitably clad person of at least 75kg or a manikin of equivalent mass must be recovered from the water under normal operating conditions. If a person is to be used in the test then that person must not assist the rescue crew in any way;
- the requirement to lift the person from the water in a horizontal position, while desirable, is considered secondary to the speed of retrieval.

On all but very low freeboard vessels some form of recovery systems will almost certainly be essential. These include:-

- for low freeboard vessels nets which have proven effective especially those incorporating a parbuckle action;
- a scoop system developed from the net technique which can be effective but demands a certain degree of operator skill to be successful;

- the use of a tackle to hoist the person out of the water which is effective but relies on attaching a strop or harness to the person and a suitably positioned eye or davit arm for the top block; and
- an adaptation of a boat hook is available which incorporates a loop which, once fitted around the person, forms a lifting harness attached to a two-fold purchase.

The effectiveness of any retrieval system depends on training and practice. Operators are reminded of the requirements of the Merchant Shipping (Musters, Training and Decision Support Systems) Regulations 1999. This notice should also be read in conjunction with MGN 17(M) Musters and Drills and On-board Training and Instruction, and MSN 1716 (M+F) Pilot Transfer Arrangements.

MSPP2C

Maritime and Coastguard Agency  
Spring Place  
105 Commercial Road  
Southampton SO15 1EG

Tel: 01703 329189  
Fax: 01703 329204

December 1999  
MS 7/08/1366

© Crown Copyright 1999



*An executive agency of the Department of the  
Environment, Transport and the Regions*



Maritime and Coastguard Agency

## MGN 141 (M)

# Equivalent Arrangements for the Carriage of Man Overboard Smoke Signals and Parachute Flares on Certain Class VI Passenger Vessels

Guidance to Owners, Operators, Masters, Officers and Ratings of Passenger Ships of Class VI

### *Summary*

The purpose of this Note is to offer the owners of certain Class VI passenger vessels an alternative arrangement for the carriage of man-overboard smoke signals and parachute flares.

1. The Merchant Shipping (Life Saving Appliances for Passenger Ships of Classes III To VI(A)) Regulations 1999, require in regulation 8 that Class VI vessels carry lifebuoys with self-activating smoke signals capable of quick release from the navigation bridge. It also states that the vessel should carry not less than 12 rocket parachute flares.
3. This arrangement will only be permitted provided it can be demonstrated to a local MCA surveyor that the vessel concerned can return to a man-overboard within 3 minutes, and the vessel's crew are proficient in the manoeuvre.

### **Man-overboard smoke signals**

2. For 'open boat' Class VI vessels without a wheel house, an alternative arrangement is permissible. When a quick-release lifebuoy and smoke float cannot be fitted, provided that the vessel is very manoeuvrable, a lifebuoy and two 3 minute smoke floats may be considered as an alternative. Such lifebuoys and smoke floats should not be stowed in close proximity to the passengers and should be kept ready for use.

### **Parachute flares**

4. Under certain local conditions eg availability of safely beaching the vessel, following local Coastguard advice and where the vessel is operating within the 10 miles from point of departure and 1 mile offshore limits, the local MCA surveyor may consider that the carriage of six parachute distress flares is sufficient rather than the prescribed twelve. When allowing this reduction, the local topography must be considered and how this might affect the sighting of the flares.

Maritime and Coastguard Agency  
Spring Place  
105 Commercial Road  
Southampton SO15 1EG

Tel: 023 80329 184  
Fax: 023 80329 204

February 2000

MS 003/001/0330

© Crown Copyright 2000



An executive agency of the Department of the Environment, Transport and the Regions

---

---

## Search and Rescue Helicopter Hi-Line Technique

Notice to Owners and Masters of Merchant Vessels, Owners and Skippers of Fishing Vessels and Masters of Yachts and all other Sea-going Vessels.

---

---

### *Summary*

This notice draws attention to mariners of a technique employed by Search and Rescue helicopter crews to recover a casualty from a vessel under certain conditions.

### High-Line Technique

In certain weather conditions it may not be possible to winch the helicopter Winchman or the strop (rescue harness) from a position directly above a vessel to the vessel's deck. Under such circumstances a weighted rope extension to the winch wire may be lowered to the vessel. This extension is known as a Hi-Line Heaving-in Line and is connected via a weak link to the aircraft's winch hook.

When the Hi-Line technique is used, once the weighted line is placed on the deck, one crew member must handle the line. **He should take up the slack on the Hi-Line and haul in ONLY when instructed to do so by the helicopter crew by radio message or hand signal. The Hi-Line must NOT be secured to any part of the vessel.** A second crew member should coil the slack line into a bucket or similar container clear of obstructions. It is advisable for the handling crew to wear protective gloves to prevent rope burns. If the helicopter has to break away during the operation the line must be paid out or, if necessary, released completely ensuring that the line passes clear outboard.

As the Hi-Line is paid out, the helicopter will move to one side of the vessel and descend.

Normally the winchman will be winched out; the ship's crew should continue to take in the slack. As the winchman or strop approach the vessel the earthing lead or hook must make contact with the vessel to discharge the static electricity before the vessel's crew make contact with the wire. Considerable effort may be needed when pulling the Winchman onboard.

Once the casualty has been secured in the strop, the Winchman, if he is present, or a member of the vessel's crew, should indicate that all is ready by making a hand signal. The helicopter will commence to winch in the wire. As this occurs a crew member should pay out the Hi-Line, maintaining sufficient firmness to prevent any swing. If the operation involves a single recovery the Hi-Line should be released once the end is reached. If further winching is required to take place then the crew member should maintain a hold on the Hi-Line and repeat the process for the next lift.

If multiple lifts are required two strops may be delivered with the hook and it is required that a casualty is placed into both strops in the normal manner.

Maritime and Coastguard Agency  
Spring Place  
105 Commercial Rd  
Southampton  
SO15 1EG

Tel: 023 80329323  
Fax: 023 80329488  
E-mail: [aviation@mcga.gov.uk](mailto:aviation@mcga.gov.uk)

October 2000

MC 23/1/01



*An executive agency of the Department of the  
Environment, Transport and the Regions*

---

---

## Guidance to Users of Inflatable Lifejackets

Note to Ship Owners, Ship Operators and Managers, Masters, Officers and Crews of Merchant Ships, Skippers and Crews of Fishing Vessels and Owners and Crews of Yachts and Pleasure Vessels.

---

---

### *Summary*

This Marine Guidance Note reminds users of inflatable lifejackets of the importance of regular inspections of inflatable lifejackets and correct procedures during donning.

The purpose of this MGN is to remind all users of inflatable lifejackets of the importance of carrying out routine and regular inspections and completing correctly all donning instructions.

The lives of users of inflatable lifejackets for both lifesaving purposes and as personnel protective equipment depend to a great extent in their equipment working when relied upon in an emergency situation. Reports of failure to provide the required level of safety can often be traced back to poor or non-existent routines for inspection and defect correction, or the equipment incorrectly donned.

Manufacturers of all approved inflatable lifejackets, their agents and the Maritime and Coastguard Agency (MCA) through maintenance procedures, instructions and Merchant Shipping Regulation, provide details of the need for regular and routine inspection of these life saving appliances, and the way to conduct these routines.

The MCA, by way of this MGN, reminds all users of life saving and personnel protective equipment of the importance to carry out all manufacturers' recommended inspection routines timely and correctly. In addition, the donning instruction issued with life saving equipment is to be followed to ensure that correct usage is applied.

Items particularly identified as being important with inflatable lifejackets, include, but are not limited to:

- a. Inspection of straps, buckles and outer cover
- b. Safety harnesses, its stitching and buckles
- c. Abrasion damage to the inflatable lung
- d. Gas inflation cylinder for signs of corrosion
- e. Gas inflation cylinder for tightness of connection to inflation mechanism

Quality Management and Systems Branch  
Maritime and Coastguard Agency  
Spring Place  
105 Commercial Road  
Southampton SO15 1EG

Tel: 023 8032 9186  
Fax: 023 8032 9204

February 2003

MS 107/026/031

© Crown Copyright 2003

*Safer Lives, Safer Ships, Cleaner Seas*

*Department for*  
***Transport***

The MCA is an executive agency  
of the Department of Transport

---

---

## Operational Issues relating to Marine Evacuation Systems

Notice to all manufacturers of Marine Evacuation Systems (MESs) and Lifejackets, and Operators, Masters and Officers of ships equipped with MESs

---

---

### *Summary*

Trials have shown that some lifejackets used with Marine Evacuation Systems have a greater sensitivity than others to “riding up” as an evacuee descends the passage. This effect is particularly marked in systems comprising a vertical chute. Operators should consult MES manufacturers for guidance about the most suitable lifejackets for use with the system and provide these for MES evacuation within a reasonable period of time (e.g. by the first survey after 31st October 2004).

Other operational issues have also been highlighted, including the need for the provision of appropriate guidance when dealing, for example, with safe descent of infants and the disabled. Appropriate training of crew members in all aspects of MES operation is vital, particularly with respect to crew response in the event of anomalies occurring during deployment.

### **Background**

1. During a recent evacuation drill in the UK using a Marine Evacuation System (MES) an evacuee became lodged in the passage and subsequently died. The Marine Accident Investigation Branch (MAIB) investigated the accident and has since published a report that included recommendations for the Maritime and Coastguard Agency (MCA). An inquest was also held.
2. The MES employed on the day of the drill was of the vertical chute type. The trial proceeded normally, and over 100 of the approximately 250 volunteers had successfully descended the chute to the liferafts when an evacuee encountered problems. The evacuee was found stuck in one of the cells of the chute, in a “piked” position (arms and legs above the head), still conscious, although their lifejacket and jacket had come off. The evacuee subsequently lost consciousness and the chute had to be cut in places to allow the evacuee to complete the descent. Despite immediate first aid and evacuation to hospital the evacuee died.
3. Although there is no evidence that riding up of the lifejacket caused the fatality it is probable that it was the initial mechanism leading to the evacuee becoming stuck in the chute. In addition to the direct risk to the individual, as demonstrated in this trial, such a blockage could delay an evacuation in an emergency.
4. It should be noted that accidents of this kind are believed to be very rare, with around 5000 successful descents to date in this make of MES alone.

## Safety Recommendations

5. Several key findings were identified in the MAIB report. These included:

- (a) the riding up of the evacuee's lifejacket either stopped them in the chute or slowed them down such that they spread their legs;
- (b) it is probable that the initial mechanism for causing the evacuee to become stuck, was the riding up of their lifejacket;
- (c) the "sweeper" (a member of the crew trained to clear such blockages) needed some sort of apparatus to help them lift the evacuee out of the piked position;
- (d) on board ships there are many types and makes of lifejackets, some of which have a tendency to ride up during the descent of MES chutes;
- (e) there is a need for the approval, both in the UK and internationally, of suitable lifejackets, which provide a safe descent for MESs;
- (f) sweepers need more effective means to clear blockages, especially during an emergency, when it is essential to keep the chute operational at all times;
- (g) although very few accidents occur during drills, there should be a specific worldwide accident reporting method to the International Maritime Organization (IMO) which can collate the evidence.

6. From the above findings, three recommendations were made to the MCA in the MAIB report:

- (a) ensure that all lifejackets on board vessels equipped with MESs within MCA's jurisdiction, are suitable for safe descent with the specific MES installed;
- (b) take to the European Union (EU) for action with regard to the EC Marine Equipment Directive and forward to the IMO the requirement that all lifejackets on board vessels equipped with MESs worldwide, are approved for use with the specific MES installed;

(c) take forward to the IMO that a reporting system should be set up, to gather reports of all accidents involving MESs.

7. At the Inquest into the fatality, the Coroner also made three recommendations to the MCA:

- (a) a lifejacket which can be pulled off the wearer should not be used in a vertical chute MES;
- (b) sweepers should receive adequate training and should carry equipment to assist in the freeing of a trapped evacuee;
- (c) a comprehensive system of collecting data of injuries/deaths associated with MESs should be created.

## Lifejacket Compatibility

8. Although there is no evidence that riding up of the lifejacket caused the fatality it is probable that it was the initial mechanism for causing the evacuee to become stuck. Trials have shown that some lifejackets used in MESs have a greater sensitivity than others to ride up, flip up, or otherwise become dislodged as the evacuee descends the passage.

9. The manufacturer of the system involved is establishing a database of lifejackets used successfully on ships with their systems.

10. Manufacturers of MESs should assess the performance of lifejackets with their systems to ensure the greatest probability of safe descent of the passage, and safe access to and entry into the associated rafts. Operators and lifejacket manufacturers are requested to provide appropriate assistance.

11. Operators should consult MES manufacturers for guidance about lifejackets suitable for safe descent of the passage and access to and entry into the rafts, and provide these for MES evacuation within a reasonable period of time (e.g. by the first survey after 31<sup>st</sup> October 2004).

### **“Sweeper” Training and Equipment**

12. The manufacturer of the MES system involved in this casualty has developed a standard list of sweeper kit required for use during an MES deployment (whether drill or emergency). This includes devices to assist with holding position in the chute, a method of communication with crew at top and bottom of chute and apparatus to help evacuees out of problem positions.
13. Manufacturers and suppliers of other systems should review their equipment and develop equivalent provisions and training requirements, and distribute these to operators of their equipment. Operators should ensure that the necessary equipment is provided and is stored adjacent to the evacuation stations and that additional training is undertaken as defined by the MES manufacturers.

### **Evacuation of Infants and the Disabled**

14. The MAIB investigation also drew attention to the specific evacuation needs of the injured, disabled and infants less than 5 years old when using MESs. Tests have now been carried out on the MES system involved to optimise methods for safe descent.
15. The manufacturer of the system involved in this case has developed a method for their particular system for holding an infant during the descent of the chute; this is now specified in the crew instruction manual. Operators should ensure that full crew training takes place to test the suggested method, and to familiarise crew with the specific installations and equipment, during deployments planned over coming months. Medical opinion indicates that the risk to an infant descending the chute is no greater than that of being carried normally by an adult.
16. It is advised, where necessary, that the disabled are strapped to a stretcher and lowered down the chute using some form of arrangement provided for use by the sweeper. These tests have demonstrated that such vertical chutes are suitable for use in an emergency by infants and the disabled.

17. Manufacturers of other systems should develop and demonstrate appropriate procedures for holding and guiding an infant down the chute or passage, and for the best method for descent of an injured or disabled person.
18. Operators are to ensure that adequate training and procedural information from the manufacturers is available on board for the use of relevant crew members and inclusion in on board training manuals. Manufacturers are to ensure that such information is provided to the operators.

### **International Action**

19. This incident has highlighted the wider issue of compatibility of lifejackets, not only in the case of MESs but also in the use of other types of survival craft. This is in line with the principles of SOLAS III/7.2, namely that lifejackets should not impede access to survival craft.
20. In response to the MAIB report and Inquest recommendations, the MCA has provided information, similar to that given within this MGN, to the IMO Design and Equipment Sub-Committee (DE 47), which is currently considering the matter of compatibility of components of life saving appliance systems. The MCA is working to ensure that MES manufacturers, ship operators and lifejacket manufacturers formally address the issue of compatibility.
21. The UK has also requested the IMO Flag State Implementation Sub-Committee (FSI 12) to update the IMO casualty reporting system to include further details on incidents involving life saving appliances and ship evacuation, as recommended by paragraphs 6(c) and 7(c). This should provide reliable statistics to assess safety of life saving appliances.

### **Conclusions**

22. This paper brings to the attention of manufacturers and operators the need for compatibility of lifejackets with MESs. It is issued in anticipation of further work to be carried out at IMO in the near future, following which additional guidance or amendments to regulations may be forthcoming.

23. It should be noted that the shipowner or operator remains responsible for ensuring, with advice from manufacturers, that the ship system as a whole is fit for purpose, in addition to SOLAS compliance of individual items of equipment, and provides for an efficient means of abandonment.

Shipping Safety Branch  
Maritime and Coastguard Agency  
Spring Place  
105 Commercial Road  
SO15 1EG

Telephone: 023 8032 9522  
Fax: 023 8032 9251  
E-Mail: [safetysafetyequipment@mcga.gov.uk](mailto:safetysafetyequipment@mcga.gov.uk)

General Enquiries: 24 Hour Info Line  
[infoline@mcga.gov.uk](mailto:infoline@mcga.gov.uk)  
0870 600 6505

MCA Website Address: Internet:  
<http://www.mcga.gov.uk>

File Ref: MS 10/9/144 and MS 7/8/1562

Published: 09/2004

© Crown Copyright 2004

*Safer Lives, Safer Ships, Cleaner Seas*

*Department for*  
**Transport**

The MCA is an executive agency  
of the Department for Transport

---

---

## **DISPOSAL OF OUT OF DATE PYROTECHNICS (MARINE FLARES)**

**Notice to all Fishermen, Leisure Craft, Shipping Service Providers, Marinas,  
Harbourmasters, Life Saving Equipment Servicing Stations, Chandlers and Suppliers**

*This notice supersedes MGN 287 (M+F)*

---

---

### **Summary**

HM Coastguard only accepts out of date marine pyrotechnics from recreational boat users and no longer accepts them from independent fishing vessels.

### **Notes:**

- a) **It is an offence to fire distress-signal pyrotechnics on land, in harbour or at sea for either testing purposes, practice or as fireworks (whether the pyrotechnics are out of date or not).**
- b) **It is an offence to dump pyrotechnics at sea**
- c) **Out of date pyrotechnics should be landed ashore as soon as possible after the date of expiry for safe disposal.**
- d) **Do not place out of date pyrotechnics in the general rubbish, or abandon them at Coastguard, RNLI or Police stations.**

Further information on the revised system for the disposal of out of date marine pyrotechnics and contact details for disposal sites can be found on either the MCA website or Directgov on the following links:

<http://www.mcga.gov.uk/c4mca/mcga07-home/emergencyresponse/mcga-searchandrescue/mcga-hmcgsar-sarsystem/pyrotechnics.htm>

or Directgov

[http://www.direct.gov.uk/en/TravelAndTransport/Boatingandtravellingbywater/Usingpleasurecraftsafely/DG\\_185790](http://www.direct.gov.uk/en/TravelAndTransport/Boatingandtravellingbywater/Usingpleasurecraftsafely/DG_185790)

## More Information

Search and Rescue Branch  
Maritime and Coastguard Agency  
Bay 2/07  
Spring Place  
105 Commercial Road  
Southampton  
SO15 1EG

Tel : +44 (0) 23 8032 9486  
Fax : +44 (0) 23 8032 9488  
e-mail: SAR.Response@mcga.gov.uk

General Inquiries: [infoline@mcga.gov.uk](mailto:infoline@mcga.gov.uk)

MCA Website Address: [www.mcga.gov.uk](http://www.mcga.gov.uk)

File Ref: CG 1/1/681

Published: July 2010  
Please note that all addresses and  
telephone numbers are correct at time of publishing

© Crown Copyright 2010

**Safer Lives, Safer Ships, Cleaner Seas**

*When printed by the MCA the material used contains a minimum 75% post-consumer waste paper*



*An executive agency of the  
Department for  
**Transport***



## MGN 294 (M+F)

### **Use of GMDSS equipment in general communications**

Notice to Masters and Officers of Merchant Vessels, Skippers of Fishing Vessels, Telecommunication Authorities and Training Institutions.

*This notice supersedes MGN 114*

#### **Summary**

This note draws attention to the contents of circular COMSAR/Circ.17 issued by the International Maritime Organization (IMO).

#### Key Points

- It is good practice to make use of GMDSS equipment for general communications in the course of normal operations as an effective test of equipment and an opportunity to enhance operator skills thereby contributing to a reduction in false alerts.

The International Maritime Organization (IMO) recommends that GMDSS equipment should be used for routine communications or testing in order to ensure equipment availability and operator competency. This also helps to reduce the false alerts transmitted inadvertently by inexperienced operators.

Use of GMDSS equipment for transmission of general radiocommunications is one of the functional requirements specified by the International Convention for the Safety of Life at Sea (SOLAS) Chapter IV, Regulation 4. Regular use of GMDSS equipment helps to develop operator competency and ensure equipment availability. If ships use other radiocommunication systems for the bulk of their business communications, a regular programme of sending selected traffic or test messages via GMDSS equipment should be adopted to ensure operator competency and equipment availability and to help reduce the incidence of false alerts. This policy extends to all GMDSS equipment suites including Digital Selective Calling (DSC) on VHF, MF and HF, to Inmarsat - A, B, C and Fleet F77 systems, and to any duplicated VHF and long range communications facilities.

#### **Further Information**

Further information on the contents of this Notice can be obtained from:

Navigation Safety Branch  
Bay 2/30  
Maritime and Coastguard Agency  
Spring Place  
105 Commercial Road  
Southampton  
SO15 1EG

Telephone: +44 (0) 23 8032 9146  
Fax: +44 (0)23 8032 9204  
E-Mail: [navigationsafety@mcga.gov.uk](mailto:navigationsafety@mcga.gov.uk)

General Enquiries: 24 Hour Infoline  
[infoline@mcga.gov.uk](mailto:infoline@mcga.gov.uk)  
0870 600 6505

MCA Website Address: Internet: <http://www.mcga.gov.uk>

File Ref: MNA 134/04/13

Published: 06/2005

© Crown Copyright 2005

*Safer Lives, Safer Ships, Cleaner Seas*

Printed on material containing 100% post-consumer waste



ISO 9001:2000  
FS 34835

*Department for*  
**Transport**

*The MCA is an executive agency  
of the Department for Transport*



Maritime and Coastguard Agency

---

---

## Shore-to-Ship Communications During a Distress

**Notice to all Masters and Officers of Merchant Vessels, Skippers of Fishing Vessels, Telecommunication Authorities and Training Institutions.**

*This note supersedes Marine Guidance Note MGN 113*

---

---

### Summary

This Note draws attention to the contents of circular COMSAR/Circ.13 issued this year by the International Maritime Organization (IMO).

#### Key Points

- It is essential communications are maintained between the Rescue Co-ordination Centre (RCC) and ships in a distress situation and Masters should ensure all assistance is given to maintain these communications.

1. Severe difficulties can be faced by Rescue Co-ordination Centres (RCCs) in contacting ships in a distress situation due to satellite communications links being jammed by other traffic.
2. Recognising the difficulty, the International Maritime Organization (IMO) issues guidance to RCCs to assist them in contacting ships fitted with Inmarsat Ship Earth Station (SEEs), busy with other traffic.
3. Masters should ensure, if in distress, or assisting in Search and Rescue, measures are taken to terminate all non-emergency communications from the ship and to offer all assistance to the RCC in maintaining communications.

## Further Information

Further information on the contents of this Notice can be obtained from:

Navigation Safety Branch  
Bay 2/29  
Maritime and Coastguard Agency  
Spring Place  
105 Commercial Road  
Southampton  
SO15 1EG

Tel: +44(0)23 8032 9146  
Fax : +44 (0) 23 8032 9204  
e-mail: [navigationsafety@mcga.gov.uk](mailto:navigationsafety@mcga.gov.uk)

General Inquiries: 24 Hour Infoline  
[infoline\(5\)mcga.gov.uk](mailto:infoline(5)mcga.gov.uk)  
0870 600 6505

MCA Website Address: [www.mcga.gov.uk](http://www.mcga.gov.uk)

FileRef: MNA134/04/13

Published: November 2005

© Crown Copyright 2005

*Safer Lives, Safer Ships, Cleaner Seas*

Printed on material containing minimum 75% post-consumer waste



ISO 9001: 2000 FS 34835

*An executive agency of the  
Department for  
**Transport***

## **Helicopter Assistance at Sea**

**Notice to all Shipowners, Masters, Officers, Ratings, Shipbuilders and Shiprepairers**

*This notice replaces MSN 1506..*

### **Summary**

This Notice gives advice on the provision of facilities for emergency helicopter operations on all types of sea-going ships which do not have a helideck, and the contingency plans which should be made and the drills which should be undertaken in anticipation of the need for helicopter assistance.

#### **1. INTRODUCTION**

1.1 Guidance on the conduct of emergency helicopter operations will be found in Notice No. 4, paragraphs 56 to 68 of the Annual Summary of Admiralty Notices to Mariners, and in the International Aeronautical and Maritime Search and Rescue (IAMSAR) Manual Vol II Chapter 6.7 and Vol III Section 2-18. Guidance on the provision of permanent winching and landing areas will be found in the International Chamber of Shipping (ICS) "Guide to Helicopter/Ship Operations" (Third Edition 1989). These publications should be read in conjunction with the advice contained in this Notice.

1.2 The success of low hover operations depends on the behaviour of the ship. If any movement is taking place, a low hover may be impracticable and may be dangerous. The decision on whether to use this technique will be made by the helicopter captain.

#### **2. GENERAL**

2.1 The use of helicopters has become commonplace to evacuate a limited number of persons from ships following a casualty, for rendering medical assistance, and for landing specialist personnel for fire-fighting, damage control and salvage purposes. Provision should be made on board ship for such eventualities. Such provision includes the selection of an area or areas over which a helicopter can safely operate, the preparation of contingency plans for helicopter operations, and the carrying out of drills. This is particularly important in the case of passenger ships which operate within helicopter coverage of the nearest coast.

2.2 Most helicopter operations are successfully executed due primarily to the skill of helicopter crews. These operations are often hazardous and their success can be better assured if owners, masters and officers make suitable provision and preparations.

2.3 Accidents have occurred in the past due to downdraft from the helicopter. All loose objects, such as ropes, tarpaulins, buoyant apparatus and headgear and garbage, located within and adjacent to the intended helicopter operating area, should be either secured or removed.

### **3. WINCHING AND LOW HOVER AREAS**

3.1 It is recommended that a dedicated **winching area** as described in the IAMSAR Manual be provided on:

3.1.1 all new sea-going ships of 100 metres in length and over; and

3.2.1 where practicable, on all other sea-going ships of 100 metres in length and over.

3.2 It is recommended that, where practicable, a clear **low hover area** large enough for a helicopter to conduct a low hover operation is provided on passenger ships. A low hover area will permit passengers and crew to board a helicopter directly from the deck thereby significantly reducing the time needed to board the helicopter. Where it is only practicable to make provision for winching it is recommended that a winching area be provided at each end of a passenger ship where this is at all possible.

### **4. CONTINGENCY PLANS, DRILLS AND COMMUNICATIONS**

4.1 Contingency plans and check lists should be prepared and periodic drills carried out. An example of a shipboard safety check list from the ICS publication "Guide to Helicopter/Ship Operations" is at Annex 1.

4.2 It is possible to communicate with the helicopter on Channel 16 VHF as it is approaching a ship. Communications will be difficult when the helicopter is overhead due to engine noise unless the ship's VHF equipment is fitted with headphones or other suitable devices for use in high ambient noise conditions. Communications will be possible if a winchman is lowered onto the ship.

## More Information

SAR Branch  
Maritime and Coastguard Agency  
Bay 1/08  
Spring Place  
105 Commercial Road  
Southampton  
SO15 1EG

Tel: +44 (0) 23 8032 9261  
Fax : +44 (0) 23 8032 9488  
e-mail: SAR.Response@mcga.gov.uk

General Inquiries: 24 Hour Infoline  
[infoline@mcga.gov.uk](mailto:infoline@mcga.gov.uk)  
0870 600 6505

MCA Website Address: [www.mcga.gov.uk](http://www.mcga.gov.uk)

File Ref: CG 23/3/3

Published: October 2006

© Crown Copyright 2006

***Safer Lives, Safer Ships, Cleaner Seas***

*Printed on material containing minimum 75% post-consumer waste paper*



*An executive agency of the  
Department for  
**Transport***

**SHIPBOARD SAFETY CHECK LIST**

Printed by HMSO, Edinburgh PressDd 8114144 9,150 11/92(205771)

To be checked by the officer in charge.

**1. GENERAL**

- (a) Have all loose objects within and adjacent to the operating area been secured or removed
  - Have all aerials, standing or running gear above and in the vicinity of the operating area
- (b) been lowered or secured?
- (c) Has a pennant or windsock been hoisted where it can be clearly seen by the helicopter pilot?
- (d) Has the officer of the watch been consulted about the ship's readiness?
- (e) Does the leader of the deck party have a portable radio transceiver (walkie talkie) for communicating with the bridge?
- (f) Are the fire pumps running and is there adequate pressure on deck?
- (g) Are fire hoses ready (hoses should be near to but clear of the operating area)?
- (h) Are foam hoses, monitors and portable foam equipment ready?
- (i) Are dry powder fire extinguishers available and ready for use?
- (j) Is the deck party complete, correctly dressed and in position?
- (k) Are the fire hoses and foam nozzles pointing away from the operating area in case of inadvertent discharge?
- (l) Has a rescue party been detailed?
- (m) Is a man overboard rescue boat ready for lowering?
- (n) Are the following items of equipment to hand?
  - (i) Large axe
  - (ii) Crowbar
  - (iii) Wire cutters
  - (iv) Red emergency signal/tor n
  - (v) Marshalling batons (at night)
  - (vi) First aid equipment
- (o) Has the correct lighting (including special navigation lights) been switched on prior to night operations?
- (p) Is the deck party ready, wearing brightly coloured tabards (waistcoats) and protective helmets, and are all passengers clear of the operating area?
- (q) Has the hook handler been equipped with helmet, strong rubber gloves and rubber soled shoes to avoid the danger of static discharge?
- (r) Is access to and egress from the operating area clear?

## **2. LANDING ON**

- (a) Is the deck party aware that a landing is to be made?
- (b) Is the operating area free of heavy spray or seas on deck?
- (c) Have side rails and, where necessary, awnings, stanchions and other obstructions been lowered or removed?
- (d) Where applicable, have portable pipes been removed and have the remaining apex ends been blanked off?
- (e) Are rope messengers to hand for securing the helicopter, if necessary? (Note: only the helicopter pilot may decide whether or not to secure the helicopter.)
- (f) Have all personnel been warned to keep clear of rotors and exhausts?

## **3. TANKERS: Additional Items for Check List**

- a) Ships not fitted with an inert gas system: has pressure been released from tanks within 30 minutes of commencement of helicopter operations?
- (b) Ships fitted with an inert gas system: has pressure in cargo tanks been reduced to slight positive pressure?
- (c) All tankers: have all tank openings been secured following venting operations?

## **4. BULK CARRIERS AND COMBINATION CARRIERS: Additional Item for Check List**

Has surface ventilation to dry bulk cargoes ceased, and have all hatch openings been fully battened down prior to helicopter operations?

## **5. GAS CARRIERS: Additional Item for Check List**

Have all precautions been taken to prevent vapour emission on deck?

---

---

## Lifejackets " Infant and Oversized Passengers "

Notice to all Owners, Operators, Masters and Crew of Passenger Ships.

---

---

**PLEASE NOTE:-**

Where this document provides guidance on the law it should not be regarded as definitive. The way the law applies to any particular case can vary according to circumstances - for example, from vessel to vessel and you should consider seeking independent legal advice if you are unsure of your own legal position.

**Summary**

The purpose of this Note is to provide general guidance on Lifejackets for Infant and Oversized passengers

The Annex to this MGN provides an advance notice to the amendments to the 1974 SOLAS Convention and the Amendments to the International Life-Saving Appliance (LSA) Code that will come into force on 1 January 2010

### 1. Introduction

- 1.1. The lifejacket is probably one of the most recognisable pieces of personal life-saving appliances. The regulations require that a lifejacket shall be provided for every person on board.
- 1.2. There is currently no statutory requirement to carry lifejackets specifically designed for infants. However, where infants might be carried on board, it is a matter of good safety management that appropriate personal life saving appliances are provided. There are products available for the personal safety of infants available in the form of floating cots or smaller lifejackets adapted for infants.
- 1.3. A related issue is the possibility that a standard lifejacket may not be suitable for larger passengers. As guidance, large can be considered as 140 kg weight, 2 m tall, or more and 1350 mm chest girth or more but up to 1750 mm. Lifejackets suiting such sizes or straps to make standard lifejackets fit to those sizes are available on the market.
- 1.4. For vessels of classes I, II and II(A) this equipment will become mandatory on the 1 January 2010. The amendments to SOLAS can be found in the Annex to this MGN.
- 1.5. Amendments to the International Life-Saving Appliance (LSA) Code, that will become mandatory on the 1 January 2010 can be found in the Annex to this MGN.

1.6. This MGN provides guidance on the best practice for dealing with these two extremes of the size scale.

## **2. Infant Lifejackets:**

2.1. Infant life jackets should:

- be clearly marked with the word "INFANT".
- be stored in a place that is clearly indicated.
- be readily available in case of emergency.

2.2. For passenger vessels on voyages with a duration of less than 24 hours, infant lifejackets are not required on board at all times. However, if the operator foresees that infants may be carried on a specific voyage or are carried during normal operations then it is recommended that:-

- People travelling with infants should be made aware of the provision of floating cots and infants' lifejackets when boarding the vessel.
- The procedure for handling, storage and distribution should be reflected in the Safety Management System.
- At least a number of infant lifejackets equal to 2.5% of the number of passengers the vessel is certified to carry should be readily available.

2.3. For passenger vessels on voyages with a duration of more than 24 hours, infant lifejackets should be provided for each infant on board:-

- People travelling with infants should be made aware of the provision and arrangements of floating cots and infants' lifejackets when boarding the vessel.
- The procedure for handling, storage and distribution should be reflected in the Safety Management System.

## **3. Oversized Lifejackets**

3.1. It is recommended that these lifejackets are always carried on board

- Oversized lifejackets should be clearly marked with the word "LARGE".
- The place of storage should be clearly indicated.
- The lifejackets should be readily available in case of emergency.
- The procedure for handling, storage and distribution should be reflected in the Safety Management System.

## **4. Crew awareness**

4.1. The crew of the vessel should be familiar with the personal life-saving appliance provided on board the vessel and trained to assist passengers in the correct donning and use of such items.

## More Information

Shipping Safety Branch  
Maritime and Coastguard Agency  
Bay 2/11  
Spring Place  
105 Commercial Road  
Southampton  
SO15 1EG

Tel : +44 (0) 23 8032 9120  
Fax : +44 (0) 23 8032 9251  
e-mail: [ShippingSafety@mca.gov.uk](mailto:ShippingSafety@mca.gov.uk)

General Inquiries: 24 Hour Infoline  
[infoline@mca.gov.uk](mailto:infoline@mca.gov.uk)  
0870 600 6505

MCA Website Address: [www.mca.gov.uk](http://www.mca.gov.uk)

File Ref: MS 003/001/0361

Published: August 2006

© Crown Copyright 2006

**Safer Lives, Safer Ships, Cleaner Seas**

*Printed on material containing minimum 75% post-consumer waste paper*



An executive agency of the  
Department for  
**Transport**

# Annex to MGN 329 Lifejackets " Infant and Oversized Passengers "

## Amendments to the 1974 SOLAS Convention

### Chapter III Life-Saving Appliances and Arrangements

#### Regulation 7 . Personal life-saving appliances

In paragraph 2.1, the following new subparagraphs .1 and .2 are inserted:

.1 for passenger ships on voyages less than 24 h, a number of infant lifejackets equal to at least 2.5% of the number of passengers on board shall be provided;

.2 for passenger ships on voyages 24 h or greater, infant lifejackets shall be provided for each infant on board;. and the existing subparagraphs .1 and .2 are renumbered as subparagraphs .3 and .4.

The following new subparagraph .5 is inserted after the renumbered subparagraph .4 of paragraph 2.1:

.5 if the adult lifejackets provided are not designed to fit persons with a chest girth of up to 1,750 mm, a sufficient number of suitable accessories shall be available on board to allow them to be secured to such persons..

## Amendments to the International Life-Saving Appliance (LSA) Code

### Chapter II Personal Life-Saving Appliances

The existing section 2.2 is replaced by the following:

#### 2.2 Lifejackets

##### 2.2.1 General requirements for lifejackets

**2.2.1.1** A lifejacket shall not sustain burning or continue melting after being totally enveloped in a fire for a period of 2 s.

**2.2.1.2** Lifejackets shall be provided in three sizes in accordance with table 2.1. If a lifejacket fully complies with the requirements of two adjacent size ranges, it may be marked with both size ranges, but the specified ranges shall not be divided. Lifejackets shall be marked by either weight or height, or by both weight and height, according to table 2.1.

**Table 2.1 . Lifejacket sizing criteria**

<b>Lifejacket marking</b>	<b>Infant</b>	<b>Child</b>	<b>Adult</b>
User's size:			
Weight (kg)	less than 15	15 or more but less than 43	43 or more
Height (cm)	less than 100	100 or more but less than 155	155 or more

**2.2.1.3** If an adult lifejacket is not designed to fit persons weighing up to 140 kg and with a chest girth of 1,750 mm, suitable accessories shall be available to allow it to be secured to such persons.

**2.2.1.4** The in-water performance of a lifejacket shall be evaluated by comparison to the performance of a suitable size standard reference lifejacket, i.e. reference test device (RTD) complying with the recommendations of the Organization<sup>1</sup>.

<sup>1</sup> Refer to the Revised Recommendation on testing of life-saving appliances (resolution MSC.81(70), as amended by resolution MSC.200(80)).

**2.2.1.5** An adult lifejacket shall be so constructed that:

- .1 at least 75% of persons who are completely unfamiliar with the lifejacket can correctly don it within a period of 1 min without assistance, guidance or prior demonstration; .
- 2 after demonstration, all persons can correctly don it within a period of 1 min without assistance;
- .3 it is clearly capable of being worn in only one way or inside-out and, if donned incorrectly, it is not injurious to the wearer;
- .4 the method of securing the lifejacket to the wearer has quick and positive means of closure that do not require tying of knots;
- .5 it is comfortable to wear; and
- .6 it allows the wearer to jump into the water from a height of at least 4.5 m while holding on to the lifejacket, and from a height of at least 1m with arms held overhead, without injury and without dislodging or damaging the lifejacket or its attachments.

**2.2.1.6** When tested according to the recommendations of the Organization on at least 12 persons, adult lifejackets shall have sufficient buoyancy and stability in calm fresh water to:

- .1 lift the mouth of exhausted or unconscious persons by an average height of not less than the average provided by the adult RTD;
- .2 turn the body of unconscious, face-down persons in the water to a position where the mouth is clear of the water in an average time not exceeding that of the RTD, with the number of persons not turned by the lifejacket no greater than that of the RTD;
- .3 incline the body backwards from the vertical position for an average torso angle of not less than that of the RTD minus 5°;
- .4 lift the head above horizontal for an average faceplane angle of not less than that of the RTD minus 5°; and
- .5 return the wearer to a stable face-up position after being destabilized when floating in the flexed foetal position.<sup>2</sup>

**2.2.1.7** An adult lifejacket shall allow the person wearing it to swim a short distance and to board a survival craft.

**2.2.1.8** An infant or child lifejacket shall perform the same as an adult lifejacket except as follows:

- .1 donning assistance is permitted for small children and infants;
- .2 the appropriate child or infant RTD shall be used in place of the adult RTD; and
- .3 assistance may be given to board a survival craft, but wearer mobility shall not be reduced to any greater extent than by the appropriate size RTD.

**2.2.1.9** With the exception of freeboard and self-righting performance, the requirements for infant lifejackets may be relaxed, if necessary, in order to:

- .1 facilitate the rescue of the infant by a caretaker;
- .2 allow the infant to be fastened to a caretaker and contribute to keeping the infant close to the caretaker;
- .3 keep the infant dry, with free respiratory passages;
- .4 protect the infant against bumps and jolts during evacuation; and
- .5 allow a caretaker to monitor and control heat loss by the infant.

**2.2.1.10** In addition to the markings required by paragraph 1.2.2.9, an infant or child lifejacket shall be marked with:

- .1 the size range in accordance with paragraph 2.2.1.2; and

---

<sup>2</sup> Refer to the illustration on page 11 of the IMO Pocket Guide to Cold Water Survival and to the Revised Recommendation on testing of life-saving appliances (resolution MSC.81(70), as amended by resolution MSC.200(80)).

.2 an .infant. or .child. symbol as shown in the .infant's lifejacket. or .child's lifejacket. symbol adopted by the Organization<sup>3</sup>.

**2.2.1.11** A lifejacket shall have buoyancy which is not reduced by more than 5% after 24 h submersion in fresh water.

**2.2.1.12** The buoyancy of a lifejacket shall not depend on the use of loose granulated materials.

**2.2.1.13** Each lifejacket shall be provided with means of securing a lifejacket light as specified in paragraph 2.2.3 such that it shall be capable of complying with paragraphs 2.2.1.4.6 and 2.2.3.1.3.

**2.2.1.14** Each lifejacket shall be fitted with a whistle firmly secured by a lanyard.

**2.2.1.15** Lifejacket lights and whistles shall be selected and secured to the lifejacket in such a way that their performance in combination is not degraded.

**2.2.1.16** A lifejacket shall be provided with a releasable buoyant means to secure it to a lifejacket worn by another person in the water.

**2.2.1.17** A lifejacket shall be provided with a suitable means to allow a rescuer to lift the wearer from the water into a survival craft or rescue boat.

### **2.2.2 Inflatable lifejackets**

A lifejacket which depends on inflation for buoyancy shall have not less than two separate compartments, shall comply with the requirements of paragraph 2.2.1 and shall:

- .1 inflate automatically upon immersion, be provided with a device to permit inflation by a single manual motion and be capable of having each chamber inflated by mouth;
- .2 in the event of loss of buoyancy in any one compartment be capable of complying with the requirements of paragraphs 2.2.1.5, 2.2.1.6 and 2.2.1.7; and
- .3 comply with the requirements of paragraph 2.2.1.11 after inflation by means of the automatic mechanism.

---

<sup>3</sup> Refer to Symbols related to life-saving appliances and arrangements, adopted by the Organization by resolution A.760(18), as may be amended.

---

---

## Hydrostatic Release Units (HRU) - Stowage and Float Free Arrangements for Inflatable Liferafts

Notice to all Owners, Masters, Officers, Skippers and Crews of Merchant Ships and Fishing Vessels

*This notice replaces MGN 104.*

---

---

### PLEASE NOTE:-

Where this document provides guidance on the law it should not be regarded as definitive. The way the law applies to any particular case can vary according to circumstances - for example, from vessel to vessel and you should consider seeking independent legal advice if you are unsure of your own legal position.

### Summary

The purpose of this Note is to provide general advice and guidance on the securing, stowage and launching of liferafts, and the fitting of the most common types of Hydrostatic Release Units - HRUs.

## 1. Required Functionally

1.1 A liferaft is required to do two things:

1.1.1 Float free and automatically inflate if the ship sinks

- This is achieved by fitting a Hydrostatic Release Unit which automatically releases when the liferaft is submerged.
- The liferaft then starts to float to the surface because of its internal buoyancy, pulling out the painter which is now only connected by the weak link at the end of the painter to the vessel.
- When the painter is pulled all the way to the end, the gas cylinder is activated, and the liferaft inflates.
- At this point the buoyancy force of the inflated liferaft is sufficient to break the weak link, and the liferaft will float to the surface, fully inflated and ready for boarding. For MED approved rafts the weak link should break at a force of between 1.8 and 2.6kN. Random pieces of small diameter line are not acceptable for use as weak links.

- Some rafts have more than one line coming from the canister. In these cases the manufacturer's literature must be consulted to establish which line is which. There may be separate firing lines, painter and multiple bousing lines.

#### 1.1.2 Be manually released and thrown overboard

- In a more controlled abandonment, the liferaft retaining strap must be capable of being released quickly and easily, eg, by senhouse slip, and the liferaft is physically thrown over the side. The painter is then pulled to inflate the liferaft.
- This system relies critically on the painter being made fast to a strong point.
- If the raft is only secured to the ship by the weak link, and is thrown over the side, the dynamic shock of being thrown over may break the weak link, instead of pulling out the painter, and therefore the whole liferaft and painter may be lost.

1.2 For these reasons the liferaft and HRU must be fitted correctly, otherwise one or both of the above functions may not work.

1.3 Diagrams and pictures showing the method of fitting some of the most common types of HRU are shown in the appendix to this note.

## 2. **Key points on the stowage of liferafts and HRUs**

### 2.1. Servicing

Re-useable HRUs must be serviced annually to ensure they will work. Disposable types do not normally need servicing during the working life indicated by the manufacturer. The manufacturer's guidelines must be followed.

### 2.2. Readily Transferable

- It is the Maritime and Coastguard Agency's view that side-to-side transfer must be accomplished in less than 5 minutes as follows:-
  - liferafts of six persons to 15 persons capacity when carried by two persons;
  - liferafts of more than 15 persons capacity when carried by four persons.
- To avoid lifting liferafts over guardrails or bulwarks, portable rails or hinged openings may be necessary. Suitable protection should be provided to prevent the possibility of persons falling over the side.
- Where doubt exists as to whether the stowage position of a SOLAS liferaft (which can weigh up to 185 kg) does allow easy side-to-side transfer, a practical demonstration must be carried out at the first Safety Equipment Certification survey.

### 2.3. Davit Launched Liferafts (DLRs)

- Must be at least 9 m forward of propeller, if physically possible.
- Must be at least 2 m above waterline at embarkation position, in fully loaded condition, unfavourable 10° trim and 20° list.
- Two crew can prepare for embarkation and launching in less than 5 minutes per raft.

#### 2.4. Marine Evacuation Systems (MES)

Rafts forming part of an MES installation must also float free in the event of a sudden sinking. Rafts must be stowed in accordance with paragraph 1.1. Any control or bousing lines that may cause the rafts to be dragged under water must be fitted with approved weak links.

#### 2.5. Remote liferafts on Cargo ships where the horizontal distance from the extreme end of the stem or stern of the ship to the nearest end of the closest survival craft is more than 100 m

- HRUs are not required.
- Must have means of rapid, easy manual release, while being secured against sea damage.
- Must have sufficient means of embarkation (a knotted lifeline is not acceptable).

#### 2.6. Ships operating in shallow waters

- On small ships, which operate in only 'favourable weather' or inland waterways, it may be practicable or preferable to arrange for liferafts to float free from their stowage without the need for HRU to hold them in place. A weak link with the correct breaking load will still be required to secure the painter to the ship so that the inflation system is activated and the inflated raft is then able to break free.
- In shallow water there is a danger that a sinking ship will touch bottom before the HRU has released or the raft has pulled enough painter/ firing line from the canister to activate the inflation system. Arrangements without HRUs should be considered, bearing in mind the possibility of accidental launching if the ship is likely to roll.
- On Open Reversible Liferafts (ORLs) the firing is typically arranged to operate after 1 – 1.5 m of line is pulled out, but this must be checked with the service station which prepared the raft. Where ORLs are stowed on cabin tops etc, the short firing line on ORLs may enable the raft to inflate before it hits the water. Where the rafts are stowed closer to the water operational procedures should cover the possibility that manual intervention may be needed to activate the inflation system. Easy access to the firing line should be available in these cases. Owners should ensure that the arrangements give the best chance of successful manual and automatic release in the circumstances and plying area.

#### 2.7. Multiple liferafts on a single HRU

- Prototype testing of HRUs is carried out in accordance with the LSA Code which only requires that the tests are carried out with a single liferaft. Approval for use of the HRU normally only applies to its use to hold down one liferaft.
- Trials have been carried out to test the effectiveness of HRUs holding more than one raft to operate when submerged to a depth of 4 m. In some cases, the additional up thrust from the rafts has been sufficient to prevent the HRU opening and releasing the rafts.
- When considering whether to accept a situation where more than one liferaft is held down by a strap attached to a single HRU, the following should be taken into account:

- when multiple liferafts are to be secured on a single HRU, owners must show that the HRU used is approved for this use;
- the arrangements should be checked to ensure that the painters are not lead or connected in such a way as to inhibit release of the rafts eg., painters running through and fouling the cradle. Each painter should have its own weak link;
- that there is sufficient other LSA available so that in the event of a single HRU not operating, there would still be adequate survival craft to accommodate the persons on the ship;
- With the introduction of disposable HRUs, the retail price of the units has been reduced. They are not expensive and it is not difficult for shipowners to fit each raft with a single unit.

## 2.8. Tensioning of HRUs

Practical experience has shown that over tensioning, whether by overtightening of the securing straps or as in 2.7.2 above, can lead to the failure of the HRU to operate. Similar problems can occur when there is insufficient load on the HRU. Securing straps should then be taut but not over tight.

## 2.9. Vessels carrying liferafts which are not approved under the Maritime Equipment Directive (MED)

Those Vessels carrying liferafts that are not certified under the MED, including those built to the ISO 9650 standard, should check the compatibility between the liferaft and the HRU. MED approved HRUs are not necessarily compatible with smaller rafts (less than 6 people) as these may not have enough buoyancy to break the weak link. Some manufactures offer special HRUs for low buoyancy rafts.

## 3. **Key Points on stowage of liferafts and HRUs**

### 3.1. Liferafts must:

- float free;
- automatically inflate;
- have launching instructions displayed;
- be lit by emergency lighting at the stowage position and launch area;
- clear projections and belting when launched;
- be secured through an approved and compatible HRU;
- be approved for the stowage height;
- have adequate length painters for the drop height.

### 3.2. Do:

- consult manufactures instructions for HRU fittings;
- stow clear of propellers and thrusters;
- stow containers with drain holes at the bottom;
- stow longitudinally in horizontally fixed cradle;
- stow to give protection from weather, smoke, soot, oil, flooding and accidental damage;
- distribute evenly port and starboard, separated longitudinally to provide redundancy in event of collision, fire etc.;
- carefully identify and remove transport lashings;
- inspect frequently for damage to the container. If it is damaged it needs to be checked by an approved service station;
- ensure liferaft can be manually released easily in an emergency by operating the senhouse slip or other release mechanism, and does not need tools or a knife.

### 3.3. Don't:

- lash in Cradles;
- stow under overhanging decks or awnings;
- allow contact with materials containing copper or copper compounds;
- hose down;
- use bottle screws instead of slips;
- concentrate on all life-saving appliances in one place.

### 3.4. Consider:

- if it will be able to float free and clear;
- interference with other rafts or lifeboats;
- effects in icing;
- effects on ships compass;
- the ability to transfer liferafts on either side;
- height above waterline – should be as near to waterline as safe and practicable;
- that the painter is many meters long and must be deployed to its full length before the liferaft will inflate. Ensure that the risk of the painter snagging on obstructions, that might prevent it from deploying fully, is minimised.

## More Information

Shipping Safety Branch  
Maritime and Coastguard Agency  
Bay 2/11  
Spring Place  
105 Commercial Road  
Southampton  
SO15 1EG

Tel : +44 (0) 23 8032 9120  
Fax : +44 (0) 23 8032 9251  
e-mail: [ShippingSafety@mcga.gov.uk](mailto:ShippingSafety@mcga.gov.uk)

General Inquiries: 24 Hour Infoline  
[infoline@mcga.gov.uk](mailto:infoline@mcga.gov.uk)  
0870 600 6505

MCA Website Address: [www.mcga.gov.uk](http://www.mcga.gov.uk)

File Ref: MS 003/089/001

Published: April 2007

© Crown Copyright 2007

***Safer Lives, Safer Ships, Cleaner Seas***

*Printed on material containing minimum 75% post-consumer waste paper*



An executive agency of the  
Department for  
**Transport**

**APPENDIX - Diagrams of common types of Hydrostatic Release Units.**  
**Hammar H20**

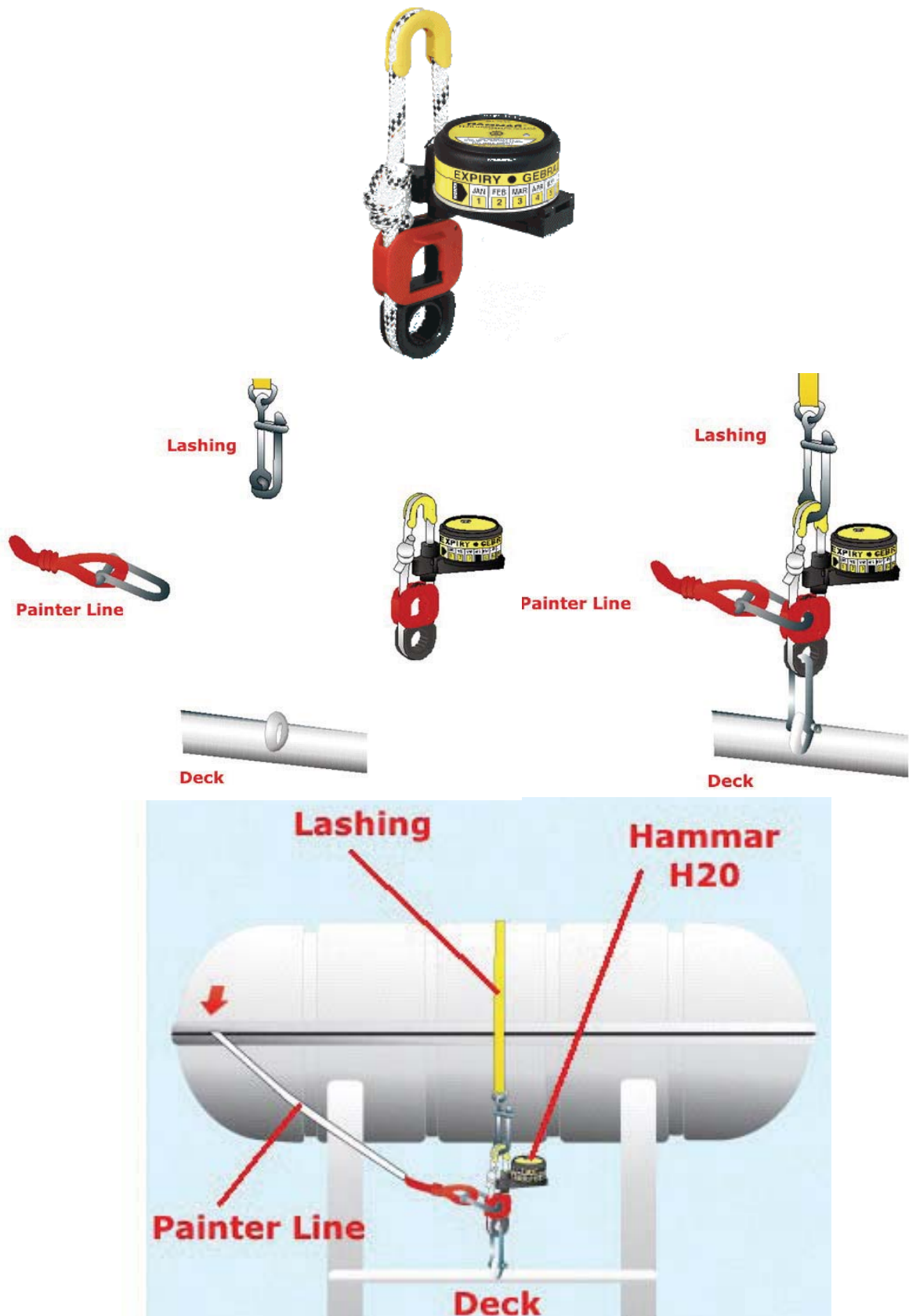

## Non SOLAS Hammar H20

There is a specific Non-SOLAS HRU that is attached in the same way as the one shown in the diagram below but its body features are green instead of yellow and the lower thimble is green instead of black.



## Thanner HRU DK- 84

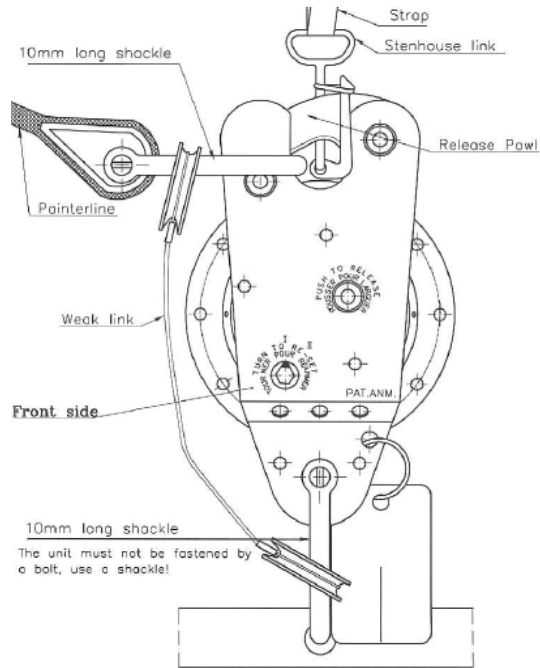

## Thanner HRU DK- 2000/2004

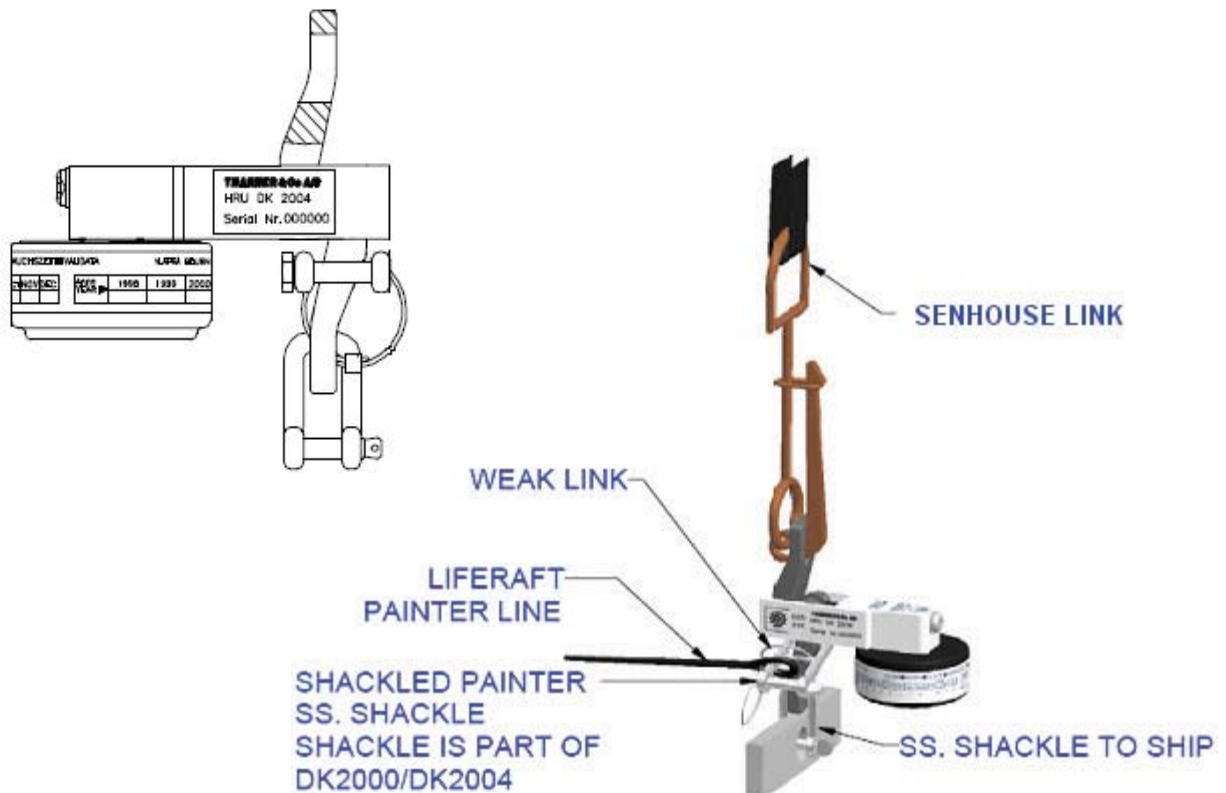

# **SALCOM SERVO-RELEASE™ S-R Mk1**

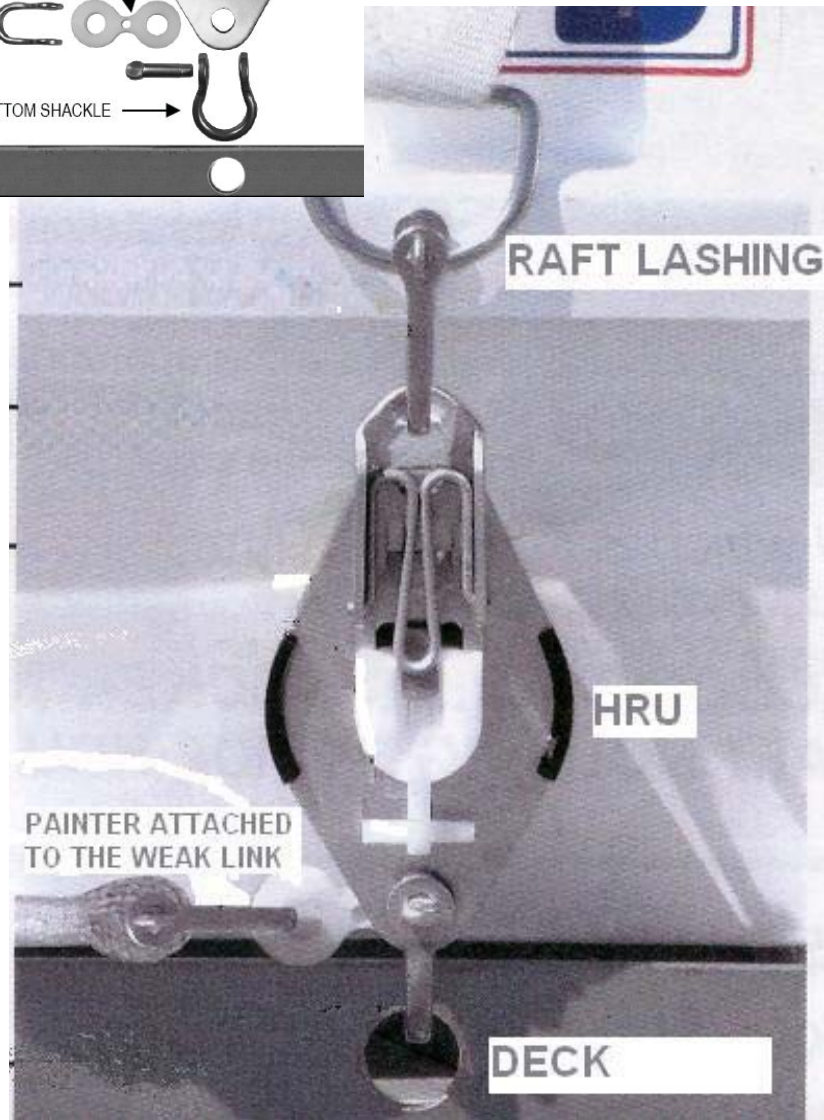
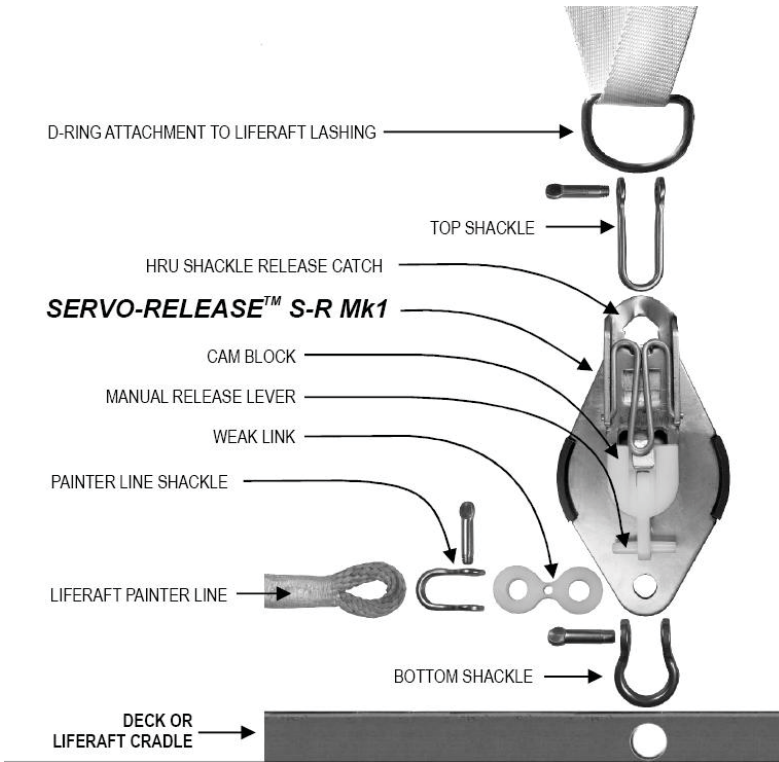

**BERWYN MK9**

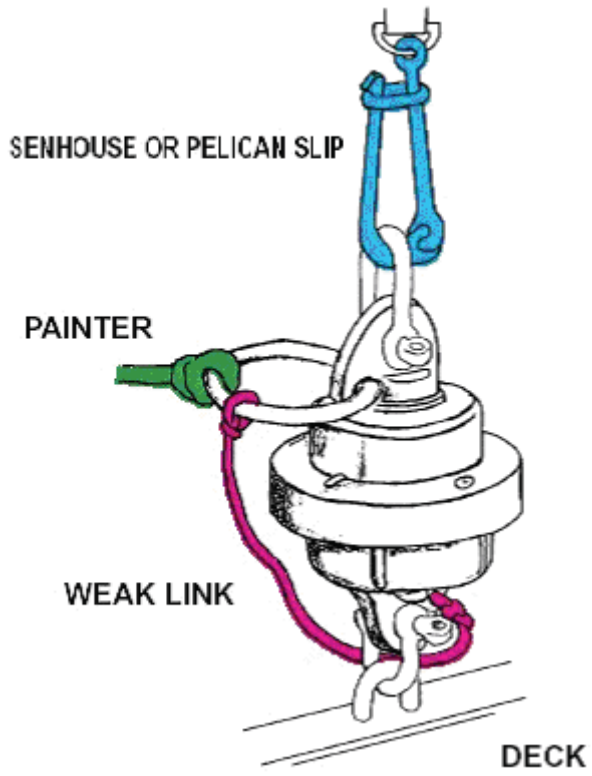

**BERWYN MK7**

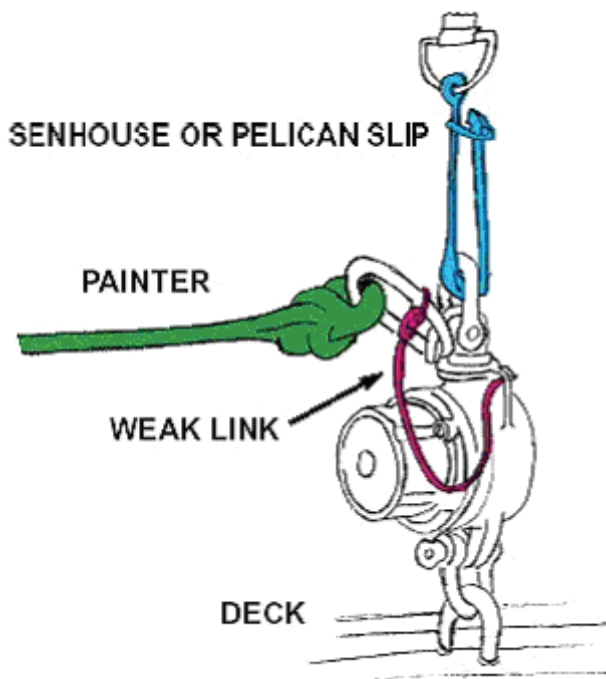

---

---

## **Observations and Recommendations arising from a Series of Domestic Passenger Vessel Evacuation Exercises.**

**Notice to all Ship Owners, Operators, Ship Designers and Marine Surveyors**

---

---

### **PLEASE NOTE:-**

Where this document provides guidance on the law it should not be regarded as definitive. The way the law applies to any particular case can vary according to circumstances - for example, from vessel to vessel and you should consider seeking independent legal advice if you are unsure of your own legal position.

### **Summary**

This guidance reports the findings of a series of trials and evacuation exercises undertaken or witnessed by the Maritime and Coastguard Agency (MCA) during 2006.

The findings are considered relevant to all passenger ships engaged on non-international (domestic) voyages, particularly those operating on rivers with strong currents, as they address a number of generic issues relevant to emergency evacuations from these vessels. The findings and conclusions identify issues that are both equipment related and operational.

Copies of the individual reports of the exercises referred to in this Note are available from the Shipping Safety Branch of the MCA upon request. Contact details are provided at the end of this Note.

### **1. Introduction / Background**

Evacuation of a domestic passenger vessel in the event of an emergency is possible by disembarkation to either dry land, attending vessels or life saving appliances. While it is important to remember that not all of these means may be available to a given vessel in a specific situation, their relative merits should be understood.

Most UK registered passenger vessels operating on domestic voyages are required to carry one or more liferafts. However, the viability of these liferafts, and in particular Open Reversible Inflatable Liferafts (ORILs), as an evacuation platform has been questioned. The main concerns expressed have related to the evacuation procedures and the feasibility of towing an ORIL and its occupants to safety, especially in a river's current or tidal stream.

Consequently, exercises were conducted to ascertain, among other things, the feasibility and effectiveness of an ORIL as an evacuation platform. An evacuation of a passenger vessel utilising attending rescue craft was also undertaken.

Knowing the time that it takes to evacuate a vessel could be critical, particularly in the case of a flooding scenario as hydrostatic stability may be lost very quickly in such circumstances. As an example:

On a 1-compartment damage stability vessel, an assumed damage of 400mm by 30mm at a position 0.25m below the waterline where it breaches the subdivision would cause a total loss of stability after 30 minutes (estimated by calculation).

On the same vessel if the damage in the same location were increased in width to 107mm, the vessel would survive less than 10 minutes.

Apart from providing an assessment of the suitability of ORILs, these exercises also identified other equipment related and operational findings which are reported and discussed in this Note.

## **2. Exercises**

Two exercises were conducted as part of the work that the MCA is currently undertaking in its Domestic Passenger Ship Regulatory Review (DPSRR) – see sections 2.1 and 2.2 below. In addition, one exercise was undertaken by the London emergency services – see section 2.3 below. Two further exercises have been witnessed by surveyors from the MCA's Falmouth Marine Office – see section 2.4 below.

### *2.1 Towing exercise on the River Thames (14<sup>th</sup> July 2006)*

An exercise was conducted by the MCA in partnership with the Royal National Lifeboat Institution, the Metropolitan Police Marine Support Unit, the London Fire Brigade and Seawater Marine Services Limited. The dynamic and lateral stability and general behaviour of an ORIL while under tow in a tidal current were observed. The raft was also observed when drifting freely in the vicinity of obstructions that a deployed ORIL is likely to encounter in a river environment.

### *2.2 Domestic Passenger Ship Evacuation Exercise on the River Thames (19<sup>th</sup> October 2006)*

The Domestic Passenger Ship Evacuation Exercise formed a part of the 2006 training day for Passenger Boat Association members, which was jointly organised by the Association and the MCA. Also essential to the organisation of the event was the assistance received from Seawater Marine Services Ltd., British Waterways and the Disabled Persons' Transport Advisory Committee.

In the exercise, 81 of 82 personnel onboard a twin decked passenger vessel were successfully evacuated after supposed damage resulting from a collision. The chosen methods of exit were recorded, although the majority of the evacuees utilised the liferafts provided. Further trials were conducted after the main evacuation exercise had been completed using persons of reduced mobility to assess the effectiveness of the arrangements (both equipment and operational) for evacuating such passengers.

### *2.3 Exercise Palm Tree on the River Thames (1<sup>st</sup> November 2006)*

Exercise Palm Tree was primarily intended to test the co-ordination and communication between London's emergency services in the event of a major maritime incident on the River Thames. The exercise involved the evacuation of passengers from a passenger vessel moored mid-stream and the search for, and rescue of, persons who had abandoned the vessel

directly into the water (as represented by mannequins for the purpose of this exercise). The participants in this exercise were the MCA, the Royal National Lifeboat Institution, the Metropolitan Police Marine Support Unit, London Fire Brigade, London Ambulance Service, the Royal Air Force, the Department for Transport, the London Boroughs of Hammersmith and Fulham and Wandsworth, and the Port of London Authority.

#### *2.4 Falmouth evacuation exercises (30<sup>th</sup> March and 26<sup>th</sup> September 2006)*

Two evacuation exercises were undertaken in the Falmouth area involving local passenger ship operators, the MCA and the Royal National Lifeboat Institution. In both exercises, there was an assumed fire onboard and an evacuation into ORILs was initiated. The first exercise in March took place in windy conditions (force 5/6, gusting 8 at times) with light rain and the September exercise, whilst winds were light, was undertaken in a swell of 1-2ft. The exercises involved an initial evacuation into an ORIL. The people in the ORIL were then transferred to an attending vessel. Subsequently, this vessel was assumed to be a casualty and these people were evacuated into an ORIL. Finally a third vessel attended to recover the ORIL and embark its occupants.

### **3. Findings from the exercises**

#### *3.1 Liferaft towing exercise (see section 2.1 above)*

The key findings of this exercise are summarised below.

##### Operational

- ◆ A suitable landing site needs to be identified when strong currents and tides are running. Travelling against the direction of flow may not be viable.
- ◆ Manoeuvring ORILs that are being towed, even when passing under bridges, does not appear unduly hazardous. However, in strong currents it may be appropriate to consider allowing the progress of the ORIL to be controlled with the 'towing' vessel upstream of the liferaft.
- ◆ The danger of a drifting liferaft colliding with, or becoming entangled in, a bridge pier or other obstruction appears to be small.
- ◆ Vessels approaching ORILs should be manoeuvred with awareness of the hazards posed by any trailing drogue and painter lines attached to the liferaft.
- ◆ Rescue vessels attending ORILs that have been deployed, especially in rivers with strong currents running, need to have sufficient power and manoeuvrability to control and, where appropriate, tow the liferafts. The crews of such rescue vessels should have the appropriate degree of training and experience and should be aware of the effect of the wash of the rescue vessel when approaching the ORIL.

##### Equipment

The following issues will be further considered by the MCA in consultation with liferaft manufacturers and other interested parties in the DPSRR.

- ◆ The deployment of drogues in river environments may increase the speed of a liferaft. Consequently, consideration will be given as to whether their positions of attachment should be clearly marked on the inside and outside of the liferaft. This comment is equally pertinent to painter lines that assist with recovery.

- ◆ It is to be considered whether the fitting of a second bridle to the towing points of a liferaft would be beneficial in those cases where the primary bridle is inadvertently cut during the liferaft's detachment from the casualty.

- ◆ Drogue lines fitted to liferafts carried on passenger vessels operating in river environments could be significantly shorter than those used at sea, to reduce the risk of interference with obstructions.

Overall, the MCA is satisfied that it has been shown that ORILs can provide a safe evacuation platform in environments such as tidal rivers until passengers can be transferred to a more permanent place of refuge.

### *3.2 Domestic Passenger Ship Evacuation Exercise (see section 2.2 above)*

The key findings of this exercise are summarised below.

- ◆ It is essential that liferafts are installed correctly on vessels in order that they deploy effectively and in a manner which allows them to be handled alongside and boarded as intended. For this reason, liferaft canisters are marked to identify which side should face inboard. Canisters containing multiple liferafts are labelled either Type A or B to indicate the manner of packing within the canister, it is suggested that the cradles for such liferafts should also be marked to indicate Type A or B and with the directions of the operating and bowing lines marked to ensure correct installation.

- ◆ There is no substitute for regular training based on varied and realistic scenarios, so that the crew have the confidence and abilities to be effective in a real emergency. It is therefore essential that the crew are familiar with emergency procedures and also with their individual responsibilities for directing and assisting passengers, launching liferafts and supervising the evacuation into liferafts. In this regard, an effective Domestic Safety Management (DSM) system must be in place.

- ◆ Crew members must be easily recognisable in the event of an emergency. It is therefore recommended that what the crew wear, or don in the event of an emergency, should make them readily identifiable to passengers and the crews of attending rescue vessels.

- ◆ Announcements made, and instructions given, by the crew to passengers in an emergency should clearly explain escape routes and the location of lifejackets. Passenger knowledge or memory of the initial safety announcement should not be relied upon. Readily accessible loud hailers or torches could improve communication during an evacuation. Effective control of passengers boarding liferafts is important, particularly in restricting hazardous items carried and worn by those about to board the liferafts.

- ◆ The evacuation procedures for persons of reduced mobility need to be properly addressed, as part of the DSM system, to ensure the rapid and safe evacuation of all onboard. This is of particular importance on vessels with higher freeboards to ensure the arrangements are appropriate. Apparatus, such as wheelchairs and pushchairs, should be removed from the evacuation area or jettisoned rather than loaded into the liferaft.

- ◆ It is recognised that the stowage of large numbers of lifejackets can prove challenging on some passenger vessels. However, stowing lifejackets with the straps in the fully tightened position will cause problems with donning; therefore straps should not be tightened when lifejackets are stowed.

- ◆ In the event of the vessel sustaining flooding, the emergency procedures should ensure that liferafts are launched and passengers readied for evacuation immediately. Even vessels of a one compartment standard are very vulnerable if damaged on the bulkhead and therefore a quick response is crucial. In deciding when, or whether, a vessel that has sustained flooding

should be evacuated, the master should be aware that there may be an absence of visual clues (for example adverse heel or trim, or reduction in freeboard) before the vessel will founder – in some cases, extremely quickly.

### *3.3 Exercise Palm Tree (see section 2.3 above)*

The key findings of this exercise are summarised below.

- ◆ Lifejackets that are stowed beneath seats may be difficult to access. It may also take some time for lifejackets, which are not stowed in evenly distributed locations around the vessel, to be allocated to all passengers in a timely manner. Consequently, donning instructions may need to be repeated several times.
- ◆ Lifejackets that are stowed adjusted to their smallest size make donning a slow and complex procedure.
- ◆ It is important that announcements and instructions made from the wheelhouse (usually using the public address system) and by the rest of the crew (in the passenger spaces, at the liferaft embarkation stations etc.) are consistent, updated and repeated at regular intervals.
- ◆ In an emergency, there is a natural tendency for passengers to crowd at the sides of the open (often upper) decks. However, this negatively impacts upon the stability of the vessel and so should be controlled by the crew to the best extent possible.
- ◆ As well as ensuring that, in the event of an emergency, communications with the emergency services are initiated as quickly as possible, it is strongly recommended that, to ensure the accuracy of distress messages transmitted by radio, the standard format of a distress broadcast is displayed in the wheelhouse next to the radio installation.
- ◆ Crew members must be easily recognisable to, and distinguishable from, the passengers. This needs to be particularly considered in the situation after lifejackets have been donned by the crew, when uniforms may be covered by the lifejackets.

### *3.4 Falmouth evacuation exercises (see section 2.4 above)*

The key finding of these exercises are summarised below.

#### Equipment

The following issues will be considered by the MCA in the DPSRR.

- ◆ An ORIL provides no protection from the elements. On a day when the air temperature was 9°C and the mean wind speed was 20 - 25 knots, after ten minutes in an ORIL most people were feeling cold. However, there was unanimous agreement among exercise participants that boarding an ORIL is considerably easier and much faster than boarding through the doorway of a canopied liferaft. It was also perceived that persons of reduced mobility would have more difficulty boarding an enclosed liferaft in a seaway.
- ◆ It is to be considered whether a “grab-bag” containing essential equipment should be kept ready at hand in the wheelhouse. Items such as a first aid kit, portable radio, flares, etc. might be placed in a sealed container that will float.
- ◆ The freeboard and high floor of an ORIL generally may make boarding and recovery of survivors easier, particularly from low freeboard passenger ships, as it is simply a case of stepping down when boarding an ORIL from the stricken ship. There are likely to be fewer obstructions, which make it easier for the less agile to board the liferafts. However, where

vessels have a higher freeboard, which is likely to slow down the evacuation process, alternative means of boarding should be considered.

### Operational

- ◆ Comprehensive briefings to passengers before and during the evacuation enhance the speed of the evacuation and help to avoid confusion and panic.
- ◆ Someone must take overall responsibility for the safe evacuation of the vessel. This needs to be addressed in the DSM system.
- ◆ The effective control of passengers is essential to the coordination of orderly evacuation. It is important that frightened or less able passengers are assisted and all passengers should be instructed as to where to sit within the liferaft. It is important that someone onboard the liferaft is in command when passengers disembark to a rescue vessel, to ensure that children, injured or weaker passengers are assisted and disembarkation is conducted in an orderly manner.
- ◆ Lifejackets should be donned as soon as abandonment appears likely.
- ◆ If necessary, able-bodied passengers can be identified by the crew and asked to assist with injured or less mobile passengers, lifejacket donning etc.
- ◆ The number and capacity of liferafts fitted on a vessel should reflect the operating environment. Larger capacity liferafts are more difficult to handle in exposed conditions, yet a number of smaller liferafts would need more crew supervision during an evacuation and multiple boarding points would be required.
- ◆ Holding a liferaft alongside a vessel in strong wind or a swell proved difficult. The raft should be secured fore and aft using the bowsing line and painter around cleats before passengers embark. Careful consideration should be given to identifying what strong points are available on individual vessels for securing liferafts.
- ◆ It is not advisable to split up family or other groups during the evacuation as this is likely to cause unease and panic amongst passengers. Passengers with impaired mobility, disability and/or injury should be identified and assigned a 'buddy' but generally board the liferafts last so that the evacuation process maintains the highest possible level of control and speed.
- ◆ Passengers should be asked to remove shoes with heels before boarding.
- ◆ Exercises to practise crowd control procedures during emergency situations should be held as part of the DSM regime. They do not need to be complicated but could take the form of a discussion to establish sensible guidelines and procedures.

The Falmouth exercises verified that ORILs can provide a suitable evacuation platform in adverse weather conditions, such as high winds and swell. The exercises also demonstrated that passengers can be successfully disembarked from an ORIL to an attending vessel.

## **4. Conclusions and recommendations for immediate consideration/action**

It is critical that the master and crew appreciate the risks of flooding damage and are fully aware of the survivability standard of their vessel. Operators and rescue services need to be fully aware of the danger of moderate damage and the speed with which a vessel can potentially be lost. Analysis has shown that there may not be sufficient visual cues to suggest imminent loss of a vessel due to a flooding situation. In the example of the evacuation exercise discussed in section 3.2 above, at the time of the simulated loss of a typical twin decked passenger vessel operating on a tidal river there was no significant heel, only 2.4 degrees of trim by the bow and 30% of the freeboard remained. An understanding of such

issues would assist Masters and rescue services in appropriately prioritising the recovery of persons from the water and the transfer of persons onboard the vessel to liferafts or attending rescue vessels.

It has been shown that the evacuation of 81 people from a passenger vessel of a similar size and arrangement to that used in Exercise Palm Tree (see section 3.3 above), into liferafts can be accomplished in less than 10 minutes. However, while this time to evacuate will vary depending on such issues as the freeboard and evacuation arrangements on individual vessels, it is expected to compare favourably to the relatively longer time for evacuation to attending rescue vessels. There may be a more significant delay in the arrival of some attendant craft than witnessed during Exercise Palm Tree, merely as a result of the unexpected nature of a real life emergency. Liferafts form a valuable element of evacuation capability if all passengers are to be removed from danger in the available time.

The frequent, considered and clear provision of information, particularly that provided over the public address system, is invaluable for instructing passengers on the correct procedures to be followed in the event of an emergency and providing ongoing additional guidance such as the need to remain low in the vessel because of stability considerations, lifejacket donning instructions and updates to passengers on the progress of the evacuation. Such announcements should be clear and honest and made in a tone which, while not inducing panic, fits the situation. Bland or overly casual messages will not reinforce the authority of the crew and are unlikely to register effectively in the surrounding atmosphere of an emergency situation. The importance of ensuring the effectiveness of communication was a common finding in all of the exercises undertaken.

Training is fundamental to ensure that the crew are confident and effective in emergency situations. Crew members should be readily identifiable, taking into account any personal life saving equipment which may be worn. They must be familiar with procedures and aware of their specific responsibilities for directing and assisting passengers, launching liferafts and supervising the evacuation. The boarding of liferafts and positioning of persons within them should be closely supervised and passengers should be refrained from wearing inappropriate footwear or carrying hazardous items such as umbrellas and bags into the liferafts.

The Domestic Safety Management (DSM) system on board the vessel should be carefully developed and regularly tested. In particular, procedures must be in place to ensure that no passengers remain on board a vessel at the end of an evacuation, bearing in mind the added difficulties which would be presented by a fire scenario. Procedures for evacuation of persons of reduced mobility also need to be clearly defined and well known by the crew. In this regard, it is recommended that passengers with reduced mobility, disability and/or injury should be identified and assigned a 'buddy'. In an emergency situation, reduced mobility passengers may be physically assisted into life saving appliances but due regard must be given to the safety of all on board in order that the evacuation process maintains the highest possible level of control and speed.

As far as practicable, lifejackets should be stowed ready to don, with no additional packaging and with straps in their most relaxed position. They are far easier to tighten than they are to loosen and this would reduce confusion, donning times and errors in donning. Clear guidance as to the method of fastening and appropriate tightening of straps should be given. It should be borne in mind that a person jumping into the water – not necessarily from a great height - while wearing a lifejacket, runs the risk of neck injuries especially if the lifejacket has been incorrectly donned or adjusted.

The exercises have demonstrated that Open Reversible Inflatable Liferafts (ORILs) provide an appropriate evacuation platform for domestic passenger ships. Furthermore, they may be essential in order to achieve a full evacuation within the time limits imposed by the survivability of the casualty.

It is recommended that the findings of this Note, particularly regarding onboard emergency procedures, the stowage and donning of lifejackets and the potential difficulties of evacuation of persons of reduced mobility, should be carefully considered and procedures and training updated as appropriate. The findings from these exercises will also be considered in the further work that the MCA is undertaking, in consultation with industry, in the DPSRR.

## More Information

Shipping Safety Branch  
Maritime and Coastguard Agency  
Bay 2/11  
Spring Place  
105 Commercial Road  
Southampton  
SO15 1EG

Tel : +44 (0) 23 8032 9179  
Fax : +44 (0) 23 8032 9251  
e-mail: [shipping.safety@mcga.gov.uk](mailto:shipping.safety@mcga.gov.uk)

General Inquiries: 24 Hour Infoline  
[infoline@mcga.gov.uk](mailto:infoline@mcga.gov.uk)  
0870 600 6505

MCA Website Address: [www.mcga.gov.uk](http://www.mcga.gov.uk)

File Ref:

Published: November 2007

© Crown Copyright 2007

**Safer Lives, Safer Ships, Cleaner Seas**

*Printed on material containing minimum 75% post-consumer waste paper*



An executive agency of the  
Department for  
**Transport**

---

---

## **Servicing of Inflatable Liferrafts, Inflatable Boats, Rescue Boats, Fast Rescue Boats, Inflatable Lifejackets and Hydrostatic Release Units.**

**Notice to all Owners, Operators and Masters of Merchant Ships, Owners and Skippers of Fishing Vessels, Code Vessels, Yachtsmen, Manufacturers and Service Station Personnel.**

*This notice replaces MGN 339 (M+F)*

---

---

### **Summary**

**Life-saving appliances should be regularly serviced at an approved service station.**

#### **Key Points:**

All above life-saving appliances carried on UK ships, Code Vessels and fishing vessels are normally required to be serviced annually, although if compliance is impracticable servicing may be deferred for a period not exceeding 5 months.

Listed as Appendices are the names and addresses of the manufacturers of the life-saving appliances and their currently appointed service station located in the UK.

The Maritime and Coastguard Agency (MCA) operates an exception scheme for extended servicing of open reversible liferafts (ORLs) fitted to Class III to VI(A) passenger vessels. These do not apply to ORLs fitted on high-speed craft or canopy liferafts fitted to the above classes of vessels.

Another exception accepted by the MCA which allows servicing intervals of up to 30 months for particular equipment when it is specially packed.

## **1. Introduction**

1.1 Under the provisions of the following Regulations, all inflatable liferafts, boats, rescue boats, fast rescue boats, inflatable lifejackets and hydrostatic release units carried on United Kingdom ships and fishing vessels are required to be regularly serviced at an approved service station:

- Regulation 11(7) of the Merchant Shipping (Life-Saving Appliances for Passenger Ships of Classes III to VI (A)) Regulations 1999.

- Regulation 84 (7) of the Merchant Shipping (Life Saving Appliances for Ships Other Than Ships of Classes III to VI(A)) Regulations 1999 as amended by Merchant Shipping (Life-Saving Appliances for Ships Other Than Ships of Classes III to VI(A)) (Amendment) Regulations 2000.
- Rule 85(2) of the Fishing Vessel (Safety Provisions) Rules 1975.
- Regulation 5 of the Fishing Vessels (Life Saving Appliances) Regulations 1988.
- Sections 12.14 and 12.26.3 of the Survey of Fishing Vessels (Instructions for the Guidance of Surveyors).

## **2. Approved Service Stations**

- 2.1 Equipment listed in paragraph 1 should normally be serviced annually, and every effort should be made to ensure that it is carried out, (however see Section 3 for exemptions). When it is clearly impracticable to comply with this annual servicing requirement, the servicing may be deferred for a period not exceeding 5 months. In such cases, masters or owners should apply to the Maritime and Coastguard Agency's (MCA) Shipping Safety Branch, explaining their reason in writing for seeking deferment.
- 2.2 The International Sailing Federation (ISAF) Offshore Special Regulations (OSR Appendix A Part 2) canister rafts, must be serviced according to the manufacturer's instructions at a manufacturer's approved service station. These rafts are acceptable on some vessels certified under the MCA's Codes of Practice for vessels under 24m (Code Vessels).
- 2.3 Inflatable lifejackets on Code Vessels should be serviced at a service station approved by the manufacturer within one month either side of the Compliance, Renewal and Intermediate examinations of the vessel. In the intervening years they are to be examined annually to the manufacturer's recommendation. Further information on inflatable liferaft and lifejacket servicing can be found in the Codes of Practice.
- 2.4 Appendix 1 lists the manufacturers and up-to-date online details of their currently appointed service stations in the United Kingdom. Manufacturers must notify the MCA with details of any changes to the UK approved service stations. Manufacturers of approved liferafts are required to have a service network of at least six in the UK. Information about location of overseas service stations is available direct from the individual manufacturers or UK representatives. Contact details of manufacturers and UK representatives are listed in Appendix 2.
- 2.5 Where a vessel is carrying a liferaft which needs servicing, but is not manufactured by one of the companies with a UK service station network, the Owner, Master or Agent should contact the manufacturer to establish the location of their approved service stations.
- 2.6 Before putting equipment in a service station, masters or owners should check the continued acceptance of the station direct from the individual manufacturer (See Appendix 1).
- 2.7 An 'approved service station' has been formally appointed by the manufacturer of an approved type of liferaft, boat or inflatable lifejacket and has been accepted by the Secretary of State. It has certificated personnel who have been trained to undertake servicing and repairs, and also to repack inflatable liferafts ready for operational use; it carries genuine spares and is kept fully informed of the current servicing procedures by the approved manufacturer. For information, an extract of IMO Resolution A.761(18) - Recommendations On Conditions For The Approval Of Servicing Stations For Inflatable Liferrafts"- is shown at Appendix 3. This extract outlines the frequency of the various tests carried out.

2.8 At every biennial servicing or servicing referred to in paragraph 3.2, of a davit launched inflatable liferaft, inflatable boat or inflatable rescue boat, a 10% overload static load test is to be carried out with the liferaft or boat suspended from its lifting hook or bridle, in accordance with the manufacturer's approved servicing instructions.

### **3. Exceptions**

3.1 An exception to the annual servicing of liferafts is that for open reversible liferafts (ORLs) fitted to Class III to VI(A) passenger vessels. The MCA introduced a scheme for extended servicing i.e. to omit the 2nd year, 4th year, 6th year and 8th year annual servicing interval. This extended servicing procedure will not apply to ORLs fitted to high-speed craft or to canopy "SOLAS" type liferafts fitted to the above Classes of vessels. Attached as Appendix 4 is a copy of the general exemption from the requirements of Regulation 11(7) of the Merchant Shipping (Life-Saving Appliances for Passenger Ships of Classes III to VI(A)) Regulations 1999. The schedule to this general exemption, attached as Appendix 5, specifically indicates the particular servicing intervals and test methods applicable to ORLs fitted on the above passenger ships.

3.2 A further exception accepted by the MCA allows servicing intervals of up to 30 months for particular equipment when it is specially packed. Special packing systems have been designed and developed by the relevant manufacturers, and these ensure that the liferafts can (i) be operated using the normal control lines, and (ii) remain protected throughout the extended servicing interval within a hermetically sealed membrane which resists water vapour transmission. Under the provisions of SOLAS 1974 Chapter III, regulations 20.8.3 and 20.8.5, the MCA has notified IMO of the arrangements accepted on United Kingdom ships. Extracts from these IMO notifications are attached at Appendices 6, 7 and 8 describe the equipment and the conditions attached to its use. These specially packed liferafts may only be serviced at suitably equipped, approved service stations.

### **4. Hydrostatic release units (HRUs)**

4.1 There are HRUs approved by the MCA which have an operational life of two years without an intermediate service being required. In this case, when the operational life of these particular HRUs has expired, they are to be returned to an authorised service station for a function test to be carried out.

4.2 There have been incidences of incorrectly installed HRUs resulting in a compromise of the float-free arrangements of the liferaft. After servicing of the liferaft and HRUs, where applicable, the liferaft and HRUs when returned on board should be installed strictly in accordance with the approved manufacturer's instructions. Details of the correct installation of the HRU to the liferaft should be provided with each unit supplied. Requirements for onboard stowage of inflatable liferafts together with hydrostatic release units are contained in Marine Guidance Note MGN 343 (M+F).

### **5. Other Information**

5.1 United Kingdom ships are required to carry Wheelmarked liferafts equipped to UK standards under the requirements of the Marine Equipment Directive.

5.2 Internationally, through the provisions of SOLAS 1974, National Administrations are responsible for the approval of servicing stations within their jurisdiction irrespective of whether or not that particular administration has approved the subject product.

5.3 It is an offence to carry an inflatable liferaft, inflatable boat, rescue boat, fast rescue boat, inflatable lifejacket or hydrostatic release unit which is known to be defective, or which has not been serviced at the intervals prescribed by the Regulations.

5.4 This MGN can be found on the MCA website at [www.mcga.gov.uk](http://www.mcga.gov.uk). Although this MGN is issued each year, the service station and manufacturer address lists will be regularly updated on the website. Please notify us at the address below of any changes or additions.

## More Information

Shipping Safety Branch  
Maritime and Coastguard Agency  
Bay 2/11  
Spring Place  
105 Commercial Road  
Southampton  
SO15 1EG

Tel : +44 (0) 23 8032 9120  
Fax : +44 (0) 23 8032 9251  
e-mail: [ShippingSafety@mcga.gov.uk](mailto:ShippingSafety@mcga.gov.uk)

General Inquiries: 24 Hour Infoline  
[infoline@mcga.gov.uk](mailto:infoline@mcga.gov.uk)  
0870 600 6505

MCA Website Address: [www.mcga.gov.uk](http://www.mcga.gov.uk)

File Ref: MS 3/14/862

Published: March 2008

© Crown Copyright 2008

**Safer Lives, Safer Ships, Cleaner Seas**

*Printed on material containing minimum 75% post-consumer waste paper*



An executive agency of the  
Department for  
**Transport**

## Appendix 1

### **Online contact information for current UK approved service stations**

#### **Avon**

[http://catalogue.avoninflatables.co.uk/\\_s-2\\_f-fc-0-408\\_ma-54.html](http://catalogue.avoninflatables.co.uk/_s-2_f-fc-0-408_ma-54.html)

#### **Baltic**

<http://www.baltic.se/service.asp?lang=eng>

#### **Crewsaver**

[http://www.crewsaver.co.uk/Industrial\\_and\\_Commercial/Lifejacket\\_Service\\_Stations/index.html](http://www.crewsaver.co.uk/Industrial_and_Commercial/Lifejacket_Service_Stations/index.html)

#### **CSM (Liferafts)**

##### **UK Representative – Nautic Service Sauvetage**

[http://www.mcga.gov.uk/c4mca/mcga-safety\\_information/ssb\\_lif\\_sav\\_appliance\\_serv\\_stations.htm](http://www.mcga.gov.uk/c4mca/mcga-safety_information/ssb_lif_sav_appliance_serv_stations.htm)

#### **Deutsche Schlauchboot GmbH & Co KG (DSB)**

<http://www.deutsche-schlauchboot.de/en/downloads/Europe.doc>

#### **Eurovinil**

<http://www.eurovinil.it/en/Service/>

#### **Fr Fassmer GmbH & Co. KG**

<http://www.fassmer.de/english/service/servicenet.html>

#### **Liferaft Systems Australia**

<http://www.liferaftsystems.com.au/service.cgi>

#### **Mullion**

[http://www.mcga.gov.uk/c4mca/mcga-safety\\_information/ssb\\_lif\\_sav\\_appliance\\_serv\\_stations.htm](http://www.mcga.gov.uk/c4mca/mcga-safety_information/ssb_lif_sav_appliance_serv_stations.htm)

#### **Remploy (Ocean Safety)**

[www.oceansafety.com](http://www.oceansafety.com)

#### **RFD / Beaufort**

<http://www.survitecgroup.com/en/rfdSite/serviceNetwork/ssByCountry.asp>

#### **Umoe Schat Harding Limited**

[www.schat-harding.com](http://www.schat-harding.com)

#### **Viking**

<http://www.viking-life.com/viking.nsf/public/servicing-listofstations.html>

#### **Zodiac/ Bombard**

<http://www.zodiacsolas.com/saleservice/index.html>

APPENDIX 2

**MANUFACTURERS & THEIR UK REPRESENTATIVES**

<p><b>Avon Inflatables Limited</b>  <a href="http://www.avoninflatables.co.uk">www.avoninflatables.co.uk</a></p>	<p>Dafan, Llanelli, Carmarthenshire SA14 8NA          Tel: 01554 882 000 Fax: 01554 882 039          E-mail: <a href="mailto:info@avon-inflatable.com">info@avon-inflatable.com</a></p>
<p><b>Baltic Safety Products UK</b>  <a href="http://www.baltic.se">www.baltic.se</a></p> <p><b>Crewsaver Ltd</b>  <a href="http://www.crewsaver.co.uk">www.crewsaver.co.uk</a></p> <p><b>DSB Deutsche Schlauchboot GmbH &amp; Co KG</b>  <a href="http://www.deutsche-schlauchboot.de/en">www.deutsche-schlauchboot.de/en</a></p>	<p>UK Representative: Unit 4, Mitchell Point, Ensign Way, Hamble, Southampton, SO31 4RF          Tel: 023 8045 7272          Fax: 023 8045 4747          E-mail: <a href="mailto:sales@baltic-uk.com">sales@baltic-uk.com</a>          Mumby Road, Gosport, Hampshire, PO12 1AQ          Tel: 023 9252 8621 Fax: 023 9251 0905          E-mail: <a href="mailto:sales@crewsaver.co.uk">sales@crewsaver.co.uk</a>          Angerweg 5, D-37632 Eschershausen, Germany          Tel: 0049 5534 3010          Fax: 0049 5534 3012          E-mail: <a href="mailto:info@deutsche-schlauchboot.de">info@deutsche-schlauchboot.de</a></p>
<p><b>UK Representative: I C Brindle &amp; Co</b>  <a href="http://www.icbrindle.com">www.icbrindle.com</a></p>	<p>34 Lytchett Drive, Broadstone, Dorset, BH18 9LB          Tel: 01202 657814          Fax: 01202 693005          E-mail: <a href="mailto:info@icbrindle.com">info@icbrindle.com</a></p>
<p><b>Delta</b>  <a href="http://www.deltapower.co.uk/support/home.html">www.deltapower.co.uk/support/home.html</a></p>	<p>Newby Road Industrial Estate, Hazel Grove, Stockport, Cheshire, SK7 5DR          Tel: 0161 456 6588          Fax: 0161 456 6686          E-mail: <a href="mailto:sales@deltapower.co.uk">sales@deltapower.co.uk</a></p>
<p><b>Eurovinil SpA</b>  <a href="http://www.eurovinil.it/en">http://www.eurovinil.it/en</a></p>	<p>Via Genova 5, 58100 Grosseto, P.IVA 01117410538, Italy          Tel: +39 0564 487452          Fax: +39 0564 487222          E-mail: <a href="mailto:info@eurovinil.it">info@eurovinil.it</a></p>
<p><b>Fr Fassmer GmbH &amp; Co. KG</b>  <a href="http://www.fassmer.de/english/service/servicenet.html">http://www.fassmer.de/english/service/servicenet.html</a></p>	<p>Industriestrasse 2          D-27804 Berne/Motzen (Weser)          Tel.: +49 4406 942-0          Fax: +49 4406 942-100          E-mail: <a href="mailto:info@fassmer.de">info@fassmer.de</a></p>
<p><b>Liferaft Systems Australia (LSA) Pty Ltd</b>  <a href="http://www.liferaftsystems.com.au/">www.liferaftsystems.com.au/</a></p>	<p>European Manager: PO Box 306, Bangor, Co. Down, BT20 9BF          Tel: 028 9127 4424          Fax: 028 9124 0138          E-mail: <a href="mailto:info@LSAMES.com">info@LSAMES.com</a></p>
<p><b>Maritime Partner As</b>  <a href="http://www.maritime-partner.com">www.maritime-partner.com</a></p>	<p>Notenesgata 1, PO Box 776 Sentrum, N 6001 Aalesund, Norway          Tel: +47 70 11 65 65          Fax: +47 70 11 65 55          E-mail: <a href="mailto:office@maritime-partner.com">office@maritime-partner.com</a></p>
<p><b>Mullion Manufacturing Ltd</b></p>	<p>44 North Farm Road, South Park Industrial Estate, Scunthorpe, North Lincolnshire, DN17 2AY          Tel: 01724 280077          Fax: 01724 280146          E-mail: <a href="mailto:jane.goodwin@uk.sioen.com">jane.goodwin@uk.sioen.com</a></p>

<b>Ocean Safety</b> <a href="http://www.oceansafety.com">www.oceansafety.com</a>	UK Representative: Ocean Safety Ltd, Saxon Wharf, Lower York Street, Southampton, SO14 5QF Tel: 023 8072 0800 Fax: 023 8072 0801 E-mail: mail@oceansafety.com
<b>RFD Beaufort Limited</b> <a href="http://www.rfdbeaufort.com/rfd_Commercial">http://www.rfdbeaufort.com/rfd_Commercial</a>	Commercial Division, Kingsway, Dunmurry, Belfast, BT17 9AF Tel: 44 (0) 2890 301 531 Fax 44 (0) 2890 621 765 E-mail: <a href="mailto:information@rfdbeaufort.com">information@rfdbeaufort.com</a> <b>(Also Lifeguard liferafts)</b> <b>(Beaufort Air-Sea Equipment Ltd) (Dunlop Marine Safety)</b>
<b>Shanghai Star Rubber Products Co. Ltd.</b> <a href="http://en.csmliferaft.com/">http://en.csmliferaft.com/</a>	No.4968 Sichen Highway (Sheshan Industrial Zone), Songjiang District Shanghai, P.R.China Tel: 00 8621 5779 7018 Fax: 00 8621 5779 7008 <a href="mailto:csmliferaft.com">csmliferaft.com</a>
<b>Nautic Service Sauvetage</b> <a href="http://www.nautic-service-sauvetage.com">www.nautic-service-sauvetage.com</a>	Parc de L'Estuaire, Avenue du Cantipou, 76700 Harfleur, France Tel: 33 02 3551 7530 Fax: 33 02 3545 7085 E-mail: <a href="mailto:servicecommercialnss@orange.fr">servicecommercialnss@orange.fr</a>
<b>Umoe Schat Harding Limited</b> <a href="http://www.schat-harding.com">www.schat-harding.com</a>	Mumby Road, Gosport, Hampshire PO12 1AE Tel: 023 9260 3893 Fax: 023 9258 2565 General E-mail: <a href="mailto:service@schat-harding.co.uk">service@schat-harding.co.uk</a>
<b>Viking Life Saving Equipment A/S</b> <a href="http://www.viking-life.com">www.viking-life.com</a>	PO Box 3060, DK-6710 Esbjerg V, Denmark Tel: 00 4576 118 100 Fax: 00 4576 118 101 E-mail: <a href="mailto:viking@viking-life.com">viking@viking-life.com</a>
<b>UK Representative</b> <b>Viking Life Saving Equipment Ltd</b>	Ferry House, South Denes Road, Great Yarmouth, Norfolk, NR30 3PJ Tel: 01493 850250 Fax: 01493 851222 E-mail: <a href="mailto:vikingldn@viking-life.com">vikingldn@viking-life.com</a>
<b>Zodiac and Bombard Liferafts (ZODIAC INTERNATIONAL)</b> <a href="http://www.zodiacsolas.com">www.zodiacsolas.com</a>	Division Marine, 2 rue Maurice Mallet, 92130 Issy Les Moulineaux, France Tel: 00 33 1 41 23 23 23 Fax: 00 33 1 41 23 23 98 E-mail: <a href="mailto:solassales@zodiac.com">solassales@zodiac.com</a>
<b>UK Representative</b> <b>International Safety Group Limited</b> <a href="http://www.ispl.co.uk">www.ispl.co.uk</a>	Orrell Mount, 159 Hawthorne Road, Bootle, Merseyside, L20 6JU Tel: 0151 922 2202 Fax: 0151 922 5874 E-mail: <a href="mailto:sales@ispl.co.uk">sales@ispl.co.uk</a>

### APPENDIX 3

#### FREQUENCY OF NAP TESTS, WORKING PRESSURE TESTS, GAS INFLATION TESTS AND FLOOR SEAM STRENGTH TESTS.

- extract from IMO Resolution A.761 (18)

<b>Servicing intervals</b>	<b>Test method</b>
End of first year	WP test
End of second year	WP test
End of third year	WP test
End of fourth year	WP test
End of fifth year	GI test
End of sixth year	WP test
End of seventh year	WP test
End of eighth year	WP test
End of ninth year	WP test
End of tenth year	GI test + FS
Eleventh to fourteenth year	NAP test + FS
Fifteenth year	GI test + NAP + FS
Sixteenth to nineteenth year	NAP test + FS
Twentieth year	GI test + NAP + FS
Twenty-first to twenty-fourth year	NAP test + FS
Twenty-fifth year	GI test + NAP + FS
Etc.	

NAP - Necessary additional pressure test

WP - Working pressure (compressed air)

GI - Gas Inflation

FS - Floor seam test

## APPENDIX 4

### GENERAL EXEMPTION

#### THE MERCHANT SHIPPING (LIFE-SAVING APPLIANCES FOR PASSENGER SHIPS OF CLASSES III TO VI(A) REGULATIONS 1999

The Secretary of State in exercise of his power under regulation 23 of the Merchant Shipping (Life-Saving Appliances for Passenger Ships of Classes III to VI(A) Regulations 1999<sup>1</sup>; hereby exempts ships to which the Regulations apply from the requirement of regulation 11(7) that open reversible liferafts, complying with the requirements of Schedule 4, Part II of the said Regulations, shall be serviced at a service station approved by the Secretary of State at intervals not exceeding 12 months, subject to the following conditions that:

1. such open reversible liferafts shall be serviced;
  - (a) at intervals not exceeding two years; and
  - (b) within the periods stated in the attached Schedule, such periods being measured from the date of manufacture; and
2. the servicing includes the test methods stated in the attached Schedule according to the age of the open reversible liferaft.

This exemption shall not apply to open reversible liferafts carried on High Speed Craft.

This exemption, which may be cancelled or modified at any time, shall remain in force until 31 May 2010.

Dated this 20<sup>th</sup> day of May 2005

**A Fairney**  
**For the Secretary of State**

---

<sup>1</sup> SI 1999/2723

## APPENDIX 5

### SCHEDULE

#### SERVICING INTERVALS AND TEST METHODS FOR OPEN REVERSIBLE LIFERAFTS CARRIED ON PASSENGER SHIPS OF CLASSES III TO VI(A)

<b>Servicing intervals</b>	<b>Test method</b>
End of first year	WP test
End of third year	WP test
End of fifth year	GI test
End of seventh year	WP test
End of ninth year	WP test
End of tenth year	GI test + FS
Eleventh to fourteenth year	NAP test + FS
Fifteenth year	GI test + NAP + FS
Sixteenth to nineteenth year	NAP test + FS
Twentieth year	GI test + NAP + FS
Twenty-first to twenty-fourth year	NAP test + FS
Twenty-fifth year	GI test + NAP + FS
Etc.	GI test + NAP + FS

NAP - Necessary additional pressure test

WP - Working pressure (compressed air)

GI - Gas Inflation

FS - Floor seam test

## APPENDIX 6

### EQUIVALENT ARRANGEMENT FOR EXTENDED SERVICING INTERVALS OF INFLATABLE LIFERAFTS.

#### Equipment Type

**RFD Endura** inflatable liferafts packed for extended service intervals. Packing consists of hermetically sealed and dessicated, reinforced and metallised foil bag within a GRP outer container.

These liferafts are type approved as indicated on Lloyds Register/ MCA type approval certificates below in accordance with SOLAS 74, Chapter III regulations 4, 20.8.3 and 34 and Chapter X regulation 3, and manufactured at the places of production as listed on the certificates listed below.

<u>Certificate Number</u>	<u>Liferaft Description</u>
MED 0250139	RFD Endura 25DL
MED 0550071	RFD Endura 6 Mk3
MED 0550072	RFD Endura 8 Mk3
MED 0550073	RFD Endura 10 Mk3
MED 0550074	RFD Endura 12 Mk3
MED 0550083	RFD Endura 12DL Mk3
MED 0550075	RFD Endura 16 Mk3
MED 0550084	RFD Endura 16DL Mk3
MED 0550076	RFD Endura 20 Mk3
MED 0550023	RFD Endura 20DL Mk3
MED 0550085	RFD Endura 20DL Mk3
MED 0550024	RFD Endura 25DL Mk3
MED 0550077	RFD Endura 25 Mk3

#### Conditions under which extended servicing intervals have been accepted

1. Servicing will be carried out at 30 month maximum intervals, only at approved servicing stations which have additionally been appointed for this purpose by Survitec Group Ltd.
2. As long as the hermetic seal has not been compromised, the 30 month service intervals will apply over the life of the product. Hermetic seal verification must be performed at maximum intervals of 12 months from the date of last service. This is done on board the ship, by measuring humidity inside the pack by means of a coloured indicator
3. Liferafts which are specially packed shall be repacked at each service using new packaging materials within the GRP outer container.
4. On loss of hermetic seal for any reason a raft will be serviced and repacked within 3 months, or 30 months from previous repacking if sooner.
5. All servicing tests prescribed in A761(18) which would have been carried out during the period of the extended service interval will be carried out by the service station at the next service after the nominal "due date" of that test.
6. Monitoring on board consists of regularly checking for moisture ingress by means of a special indicator, and completion of an inspection log which remains aboard the ship; as indicated in the equipment type approval certificate.

7. Passenger ships equipped with liferafts specially packed as above will comply with SOLAS regulation III 19.4.3 by carrying aboard, or having ready access to, a conventionally packed training raft of similar type and means of operation, or by carrying a visual training aid which can simulate inflation and davit launching of such liferafts.

8. In addition to other required marks, the outer containers of specially packed Endura liferafts within the extended servicing scheme carry the following label:

This RFD 'Endura' Liferaft has been designed and manufactured in accordance with the SOLAS 1996 Amendments, regulation 20 paragraph 8.3 and the IMO '2000 HSC Code', chapter 8 paragraph 8.9.9, which permit Extended Service Intervals of 30 months.

To comply with this, the liferaft must be inspected on board by a person certified for such purpose by Survitec Group Ltd at intervals not exceeding 12 months. The record of such inspection must be entered on an Inspection Log Card.

The liferaft must be serviced at intervals of 30 months at a Survitec Group Ltd approved liferaft service station in accordance with regulation 20, paragraph 8.1.2.

## APPENDIX 7

### EQUIVALENT ARRANGEMENT FOR EXTENDED SERVICING INTERVALS OF INFLATABLE LIFERAFTS

#### Equipment Type

**Zodiac** (or Bombard) inflatable liferafts with SOLAS 'A' and 'B' packs of the following models:

Throw over – 6, 8, 10, 12, 16, 20, 25 and 50 persons;

Throw over self righting – 6, 25, 37 and 50 persons;

Davit launched – 12, 16 and 20 persons;

Davit launched - 25 and 37 persons;

Davit launched self righting - 25 and 37 persons.

The liferafts are packed for extended service intervals by enclosure within a sealed polyurethane membrane, located within the GRP outer container (the Extended Packing Service, EPS system). The inflation gas cylinders are fitted with accurate temperature and pressure transducers connected to a port which can be accessed without disturbing the sealed polyurethane membrane.

The liferafts are manufactured by ZODIAC INTERNATIONAL, Issy-les-Moulineaux, France; type approved by Bureau Veritas in accordance with SOLAS 74, Chapter III, regulations 4, 20.8.3 and 34 and Chapter X regulation 3; as evidenced by certificates Nos.

15641/A0 EC	15641/A0 MMF	15561/A0 EC	15561/A0 MMF
15666/A0 EC	15666/A0 MMF	15667/A0 EC	15667/A0 MMF
13298/A1 EC	13300/A0 EC	13301/A0 EC	13302/A1 EC
13305/A1 EC	13303/A1 EC	12930/A0 EC	13297/A0 EC
13304/A0 EC	13299/A0 EC	13148/A0 EC	16045/A1 EC
16046/A1 EC			

#### Conditions under which extended servicing intervals have been accepted on United Kingdom ships.

1. Servicing will be carried out at 30 month maximum intervals, only at approved servicing stations which have additionally been appointed for this purpose by Zodiac International.
2. Zodiac International will provide the MCA with the results of comparative study on the ageing of liferaft fabric and pressure seams, using material samples variously exposed, and tested at 2 ½, 5, 7 ½ and 10 years of age.
3. EPS liferafts shall be repacked at each service using new packaging materials within the GRP outer container.
4. On deployment, or damage to membrane, or pressure within gas inflation cylinder falling below a limit defined by the manufacturer, a raft will be serviced and repacked within 3 months, or 30 months from a previous repacking, if sooner.
5. All servicing tests prescribed in A761(18) to be carried out, according to the age of the liferaft, during the period of the elapsed extended service interval will be carried out by the service station prior to repacking.
6. Monitoring on board by certified personnel consists of annually checking inflation gas pressure and temperature by means of a special indicator, and completion of an inspection card which travels with the liferaft.

7. Passenger ships equipped with any of the above EPS liferafts will comply with SOLAS regulation III/ 19.4.3 by carrying aboard, or having ready access to, a conventionally packed training raft of similar type and means of operation, or by carrying a visual training aid which can simulate inflation and davit launching of such liferafts.

8. In addition to other required marks, the outer containers of EPS liferafts which are serviced at extended intervals will be marked:

(i) with the words '*EPS liferaft 30 months servicing*' within a disc bearing year and month numerals, and

(ii) with the words '*EPS liferaft 12 months control on board*' within a second disc bearing year and month numerals.

## APPENDIX 8

### EQUIVALENT ARRANGEMENT FOR EXTENDED SERVICING INTERVALS OF INFLATABLE LIFERAFTS

#### Equipment Type

**Viking** S30 inflatable liferafts packed for extended service intervals. Packing consists of hermetically sealed and desiccated, hermetically sealed pouch within a GRP outer container.

These liferafts are type approved as indicated on Det Norske Veritas/ Norwegian Maritime Directorate type approval certificates below in accordance with SOLAS 74 as amended, Chapter III regulations 4, 21.1, 31.1, 34 and Chapter X regulation 3, the resolution MSC.81(70), IMO MSC/Circ.811 and HSC Code 8.1, 8.5, 8.6. 8.7 & 8.10., and manufactured at the places of production as listed on the certificates listed below.

<b><u>Certificate Number</u></b>	<b><u>Liferaft Description</u></b>
MED-B-3336	6 DK+S30
MED-B-3337	8 DK+S30
MED-B-3338	10 DK+S30
MED-B-3339	12 DK+S30
MED-B-3340	16 DK+S30
MED-B-3341	20 DK+S30
MED-B-3335	25 DK+S30
MED-B-3334	35 DK+S30
MED-B-3342	12 DKF+S30
MED-B-3344	16 DKF+S30
MED-B-3443	20 DKF+S30
MED-B-3403	25 DKF+S30
MED-B-3404	35 DKF+S30

#### **Conditions under which extended servicing intervals have been accepted**

1. Servicing will be carried out at 30 month maximum intervals, only at approved servicing stations which have additionally been appointed for this purpose by Viking Life-Saving Equipment A/S
2. As long as the hermetic seal has not been compromised, the 30 month service intervals will apply over the life of the product. Hermetic seal verification must be performed at maximum intervals of 12 months from the date of last service. This is done on board the ship by certified personnel.
3. Liferafts which are specially packed shall be repacked at each service using new packaging materials within the GRP outer container.
4. On loss of hermetic seal for any reason within the first 12 months then a raft will be serviced and repacked within on or before month 12 or 30 months from previous repacking if sooner.' On loss of hermetic seal for any reason after month 12 a raft will be serviced and repacked within 3 months, or 30 months from previous repacking if sooner.
5. All servicing tests prescribed in A761(18) which would have been carried out during the period of the extended service interval will be carried out by the service station at the next service after the nominal "due date" of that test.

6. Monitoring on board is to be done by certified personnel and they will check the humidity based on a computer program that checks the humidity levels and any CO2 leakages. All readings are recorded on the computer. A label, with the date and the liferaft serial number, is then printed and placed on the individual liferaft certificate onboard the ship, as documented evidence for record and inspection purposes.

7. Passenger ships equipped with liferafts specially packed as above will comply with SOLAS regulation III 19.4.3 by carrying aboard, or having ready access to, a conventionally packed training raft of similar type and means of operation, or by carrying a visual training aid which can simulate inflation and davit launching of such liferafts.

8. In addition to other required marks, the outer containers of specially packed S30 liferafts within the extended servicing scheme carry the following label:

1. This liferaft is permitted for extended service intervals of 30 months at an approved service station.
2. The liferaft must be inspected on board by a person certified for such purpose by Viking Life-saving Equipment A/S at intervals not exceeding 12 months.

---

---

## Compatibility of Life-Saving Equipment

Notice to all Owners, Operators, Masters, Marine Equipment Suppliers & Surveyors

---

---

**PLEASE NOTE:-**

Where this document provides guidance on the law it should not be regarded as definitive. The way the law applies to any particular case can vary according to circumstances - for example, from vessel to vessel and you should consider seeking independent legal advice if you are unsure of your own legal position.

**Summary**

A number of issues have been highlighted with regards to the unsuitability of some immersion suits and lifejackets.

Information provided is intended to give guidance when taking into account the issue of compatibility of immersion suits and lifejackets when jointly used.

### 1. Introduction/ Background

1.1 Standards for lifejackets and for immersion suit specifications are outlined within the Life-Saving Appliances Code (LSA Code). They do not fully address the wider issue of compatibility and suitability of lifejackets and immersions when worn together, such as buoyancy, flotation position and self-righting performance. Chapter II of the LSA Code outlines the general requirements for Lifejackets (Section 2.2), Immersion Suits (Section 2.3) and Anti-Exposure Suits (Section 2.4).

1.2 In summary, the requirements of the LSA Code include:

- a) "a lifejacket, when worn on its own, will:
  - i) lift the mouth of an exhausted or unconscious person not less than 120mm clear of the water .....; and
  - ii) turn the body of an unconscious person in the water from any position to one where the mouth is clear of the water. (LSA Code 2.2.1.2);
- b) an immersion suit (one which does not have sufficient buoyancy to be also classed as a lifejacket), will when worn in conjunction with a lifejacket, permit:
  - i) the test subject to float face-up with their mouths clear of the water by at least 120mm and be stable in that position; and

ii) a person in fresh water.....shall be able to turn from a face-down to a face-up position. (LSA Code 2.3.3)”

## 2. Guidance

2.1 The LSA Code tests for immersion suits do not necessarily ensure that any given type of immersion suit is compatible with any given lifejackets. The LSA Code requirements with regards to buoyancy requirements for immersion suits will change as from 1st January 2010, (MSC.207 (81)). Extra care should be taken where the lifejacket is of a design with no “behind the neck” buoyancy – this type of lifejacket could actually lead to a survivor being inclined head down in the water when worn in combination with an immersion suit. It will be necessary to seek advice from the Chandler/manufacturer when considering using lifejackets and immersion suits in combination - they may be able to indicate a type of lifejacket and immersion suit which have been tested satisfactorily in combination. Alternatively, operators may wish to conduct their own tests in accordance with the guidance referenced in the following paragraphs.

2.2 The Health and Safety Executive (HSE) commissioned research into the issue of compatibility of immersion suits and lifejackets, with the objective to produce a protocol to enhance the testing regime within the offshore sector. The Protocol assists Duty Holders to satisfy themselves that the different items of equipment are compatible and are suitable for use offshore. The HSE document outlines the acceptable additional criteria for "compatibility testing". The title of the document is:

*Compatibility test protocol for lifejackets and immersion suits on offshore installations. [Offshore Technology Report 2002/021], which was prepared by Mensafe Ltd for the Health and Safety Executive.*

The document is available electronically at the following hyperlink:

<http://www.hse.gov.uk/research/otohtml/2002/oto02021.htm>

## 3. LSA Code & ISM Code

3.1 Although the LSA Code does specify a number of testing requirements in section 2.3.1.3, this does not fully address the compatibility issues. As such, the HSE document should be noted when assessing the potential implications of incompatible immersion suits and lifejackets within the maritime industry.

3.2 This MGN draws the attention to the principles of the International Safety Management (ISM) Code, which states that the safety management objectives of the Company should, among other things, establish safeguards against all identified risks. Consequently, it should be noted that the shipowner or operator is responsible for ensuring, with advice from the relevant manufacturers, that the LSA system as a whole is fit for purpose, in addition to SOLAS compliance of individual items of equipment. In particular, care should be taken that the full and free movement is available, that fixed gloves do not prevent operators from handling controls of LSA equipment, and that sufficient suits are provided in sizes appropriate for the crew onboard (i.e. including children) as required by Regulation 32.3 of SOLAS Chapter III.

## 4. Other Issues

4.1 Compatibility of lifejackets and immersion suits is one aspect of the wider issue of compatibility of LSA equipment for all types of survival craft and Marine Evacuation Systems (MES). Specifically, compatibility of MES and lifejackets was highlighted in MGN 273(M) – “Operational issues relating to Marine Evacuation Systems”.

- 4.2 The HSE document may also be of benefit in considering compatibility in line with the principles of SOLAS III/7.2, namely that lifejackets should not impede access to survival craft. By extension, the combined use of lifejackets and immersion suits must provide for an efficient means of abandonment. It should be noted that there should be appropriate sizes of approved lifejackets for all persons onboard.
- 4.3 The 84th session of the IMO Maritime Safety Committee issued guidance on the wearing of immersion suits in totally enclosed lifeboats. This document, MSC.1/Circ 1278 is attached to this MGN as Annex A.

### More Information

Marine Technology Unit  
Maritime and Coastguard Agency  
Bay 2/29  
Spring Place  
105 Commercial Road  
Southampton  
SO15 1EG

Tel : +44 (0) 23 8032 9100  
Fax : +44 (0) 23 8032 9251  
e-mail: [natacha.southwell@mcga.gov.uk](mailto:natacha.southwell@mcga.gov.uk)

General Inquiries: [info@mcga.gov.uk](mailto:info@mcga.gov.uk)

MCA Website Address: [www.mcga.gov.uk](http://www.mcga.gov.uk)

File Ref: IMS003/072/0051

Published: June 2009  
Please note that all addresses and  
telephone numbers are correct at time of publishing



© Crown Copyright 2009

**Safer Lives, Safer Ships, Cleaner Seas**

*Printed on material containing minimum 75% post-consumer waste paper*

*An executive agency of the  
Department for  
**Transport***

**INTERNATIONAL MARITIME ORGANIZATION**  
4 ALBERT EMBANKMENT  
LONDON SE1 7SR

Telephone: 020 7735 7611  
Fax: 020 7587 3210

Ref.: T4/3.01

MSC.1/Circ.1278  
23 May 2008

## **GUIDANCE ON WEARING IMMERSION SUITS IN TOTALLY ENCLOSED LIFEBOATS**

- 1 The Maritime Safety Committee, at its eighty-fourth session (7 to 16 May 2008), considered the recommendations made by the Sub-Committee on Ship Design and Equipment at its fifty-first session, with regard to potential risks of overheating and dehydration associated with the wearing of immersion suits inside totally enclosed lifeboats, and approved the following guidance.
- 2 Experience gained during the January 2007 abandonment of the containership **MSC Napoli** during a winter storm in the English Channel highlighted the potential risks of wearing of immersion suits in totally enclosed lifeboats. Although outside temperatures were frigid, a number of crew wearing immersion suits suffered from overheating and dehydration. In document DE 51/INF.8, the Republic of Korea reported similar experience with immersion suits worn during abandon ship drills in moderate conditions, where crew experienced discomfort in a very short period of time, due both to overheating and to interference with seating arrangements.
- 3 Totally enclosed lifeboats have long been considered to provide adequate protection from hypothermia without the need for the occupants to wear immersion suits. The revised SOLAS regulation III/32 (as amended by resolution MSC.152(78)) requires to carry immersion suits for all persons on board cargo ships, regardless of carriage of totally enclosed lifeboats, stemming from reports of casualties in which the ship sank too quickly for crew to access the lifeboats. Immersion suits were required in order to ensure that thermal protection is available in the event that members of the crew are unable, for whatever reason, to embark on the lifeboats.
- 4 In general, immersion suits should not be worn when boarding totally enclosed lifeboats. While abandon ship drills are a good opportunity to examine and demonstrate the use of immersion suits, crew training during these drills should emphasize that immersion suits are intended primarily to ensure thermal protection in cases where the totally enclosed lifeboat cannot be embarked on.
- 5 Member Governments are invited to use the aforementioned guidance and to bring it to the attention of all parties concerned.

**LIFEBOAT WINCHES FITTED WITH A ROLLER RATCHET MECHANISM****Notice to Shipowners, Masters, Safety Officers and Shiprepairers**

In 1981 a seaman was injured whilst assisting in the recovery of a lifeboat/passenger launch on a passenger cruise liner. The boat was also badly damaged. The incident occurred as the boat was being hoisted on board the liner by an electric boat winch. When the boat reached Boat Deck level the launching crew began fitting the tricing pendants as the winch operator stopped the winch. The brake apparently failed to hold the boat and although one of the tricing pendants had been connected to the lower block it could not hold the boat in position. The pendant parted causing the boat to swing violently and drop on the falls into the sea. As the boat swung one of the launching crew was thrown into the sea and injured; fortunately the Chief Officer and the other seamen in the launching crew jumped clear and were not injured.

When the brake was opened up for examination it was found to be in good condition and working satisfactorily; the roller ratchet mechanism within the winch was then suspected as being the principal cause of this incident, but upon subsequent examination it too was found to be in an apparently satisfactory condition.

Examination of our records then showed that a number of similar winch failures had occurred in recent years but fortunately in none of these cases had anyone been injured or any of the boats damaged. In each case however, it was noted that the failure occurred to a winch which had been used for the launching and recovering of a lifeboat/passenger launch, a type of boat which is in frequent use on most cruise liners.

In view of these past failures and the knowledge that they could have led to disastrous results, an extensive programme of winch testing was carried out by one of the country's leading winch manufacturers. As a result of this work it has been concluded that the most probable cause of these winch failures was the weakening of the springs used to retain the rollers in position within the ratchet. The weakening was due to the frequent use of these particular winches on passenger cruise liners.

Consequently, Shipowners, Masters and Safety Officers are strongly recommended to ensure that winches used for the launching and recovery of any boat are regularly checked. In addition:—

- (a) Any winch used for any lifeboat/passenger launch fitted on a UK passenger ship or any other highly worked survival craft or work

boat shall be opened up and thoroughly examined every two years. In addition, it is recommended that on those winches which are fitted with roller ratchets the opportunity should be taken to renew the roller retaining springs at these biennial examinations;

- (b) Any winches used for a traditional lifeboat fitted on any ship (which is likely to be used less frequently than a lifeboat/passenger launch) should be opened up for thorough examination at intervals not exceeding 4 years as indicated in paragraph 3.11.2 of "Survey of Life Saving Appliances—Instructions for the Guidance of Surveyors". If roller ratchets are fitted to these winches then the roller retaining springs should be renewed during such examinations;
- (c) Winches used for any type of survival craft, work boat or launch should, if fitted with a roller ratchet mechanism, have such mechanisms regularly maintained. The ratchet mechanisms should never be packed with grease; a light non-solidifying grease or light oil should be lightly smeared on the mechanisms to assist easy movement and to prevent the onset of corrosion.

It is also recommended that ships fitted with winches incorporating a roller ratchet mechanism carry an adequate supply, or at least one complete set, of spare roller retaining springs.

Department of Transport  
Marine Directorate  
London WC1V 6LP  
August 1985

© Crown copyright 1985

**EMERGENCY EQUIPMENT LOCKERS FOR RO/RO PASSENGER SHIPS****Notice to Shipowners, Shipbuilders, Shiprepairers, Suppliers of Ships' Equipment, Masters, Officers and Seamen**

*(This notice is to be read in conjunction with the Merchant Shipping (Emergency Equipment Lockers for Ro/Ro Passenger Ships) Regulations 1988)*

**1. INTRODUCTION**

1.1 This Merchant Shipping notice contains guidance on the lockers and emergency equipment required by the Merchant Shipping (Emergency Equipment Lockers for Ro/Ro Passenger Ships) Regulations 1988 and in paragraph 3.1 lays down the required scale of equipment. These Regulations apply to United Kingdom ro/ro passenger ships of Classes I, II, II(A) and IV.

1.2 The provision of such lockers and equipment was a recommendation of the Court of Formal Investigation into the loss of the Herald of Free Enterprise. The purpose of the equipment is to provide means in unusual circumstances, eg when a ship is at a very large angle of heel, to assist passengers and crew to escape from enclosed spaces within the ship when the normal escape arrangements cannot be used. Some of the emergency equipment will also be of assistance during damage control operations, and in assisting with escape when the normal escape routes are obstructed by debris or by doors jammed in the closed position.

**2. LOCKERS****2.1 Number**

2.1.1 At least one locker must be provided on each side of the ship. Where only one locker is provided on each side it should be large enough to contain the equipment listed in paragraph 3.1. Where more than one locker is provided on each side each locker should contain at least sufficient equipment to deal with escape from one side opening, eg hand lamp/torch, two adult lifting strops and a hand-powered lifting arrangement with associated rope.

**2.2 Location**

2.2.1 The prime consideration in the location of the lockers is that the locker (or lockers) on at least one side will be available for use in all foreseeable circumstances. The lockers must be located on an open deck as high up in the ship and as near the ship's side as possible compatible with there being sufficient access outboard of the locker for opening the door or lid.

2.2.2 Where only one locker is fitted on each side of the ship, location near the bridge is advantageous from security and prevention of vandalism aspects. Where more than one locker is fitted on each side, the positions in which they are located should be widely separated longitudinally.

2.2.3 Where possible a locker should be located in an area which can be illuminated by the main and emergency lighting.

**2.3 Construction**

2.3.1 Lockers must be constructed of steel or GRP or other suitable material and be weathertight. They may be free-standing or integral with the superstructure. Access to free-standing lockers may be by means of vertical doors or horizontal lids. Vertical doors should face outboard and horizontal lids should be hinged on the inboard side. Doors or lids should be provided with means to hold them in the open position when the ship is both upright and at a large angle of heel when the locker is on the high side. A lid should be held in the horizontal position when the ship is heeled at an angle of 90°.

2.3.2 The interior of a locker should be fitted with clips or arrangements to hold tools, handlamps and heavy equipment securely in position.

2.3.3 Lockers should be so secured to the ship's structure that they will remain in position at an angle of heel up to 90°.

2.3.4 Lockers should be capable of being locked. If not fitted with a break glass key box the door, or the locker itself, should be so constructed that access can be gained by means of a kick-in panel.

2.3.5 A free-standing locker should be of a conspicuous colour, eg international orange. If integral with the ship's structure the door should be of a conspicuous colour.

2.3.6 A locker should be identified by a label marked with the words "EMERGENCY EQUIPMENT". The label should be made of a photoluminescent material. If the key is kept in a break glass box this should also be identified by photoluminescent material.

### 3. EMERGENCY EQUIPMENT

3.1 Emergency equipment should be of good quality and the following minimum scale of equipment is specified for the purpose of the Regulations and should be provided on each side of the ship and stowed in one or more lockers:

Fireman's axe (long handled)	1
Fireman's axe (short handled)	1
Pin maul (7 lb)	1
Crowbar	1
Hand lamp/torch	4
Padded lifting strop (adult) <sup>(1)</sup>	6
Padded lifting strop (child) <sup>(2)</sup>	2
Hand-powered lifting arrangement <sup>(1,3)</sup>	3
Lightweight rigid collapsible ladder at least 3 metres long <sup>(4)</sup>	1
Lightweight rope ladder (equal in length to beam of ship or 10 metres whichever is less <sup>(4)</sup> )	1
First Aid Kit	1
Blankets (sealed in plastic bags) or thermal protective aids	6
Waterproof jackets and trousers	4 sets

Notes;

- (1) In ships under 100 metres in length the number of adult lifting strops and lifting arrangements may be reduced to 4 and 2 respectively.
- (2) Not required if the adult lifting strop is also suitable for children.
- (3) Lifting arrangements to be capable of being used at angles of up to 20° from the horizontal and to have a SWL of at least 150 kg.  
Rope if used to be of a type which features good grip. One end of rope to be fitted with a snap link suitable for securing to lifting strops. Tensile strength of rope and snap link to be at least 1 tonne. Length to be suitable for lowering harness a distance equal to at least 2/3 beam of the ship taking into consideration the type of purchase (if any). If wire used in the lifting arrangement tensile strength and length to be of equivalent standard.
- (4) Ladder to be capable of supporting one person weighing up to 150 kg and to be provided with means of support at top end when suspended from side escape when ship is on its beam ends.

3.2 The equipment should be so stowed and secured in the locker that it will not drop out when the door or lid is opened when the ship is heeled at an angle of 90°.

### 4. DRILLS AND ON-BOARD INSTRUCTION

4.1 The circumstances of an emergency may be such that the first crew members on the scene could be from any rank, rating or department. Consequently, it is most important that all crew members take part in drills and instruction sessions in order to gain familiarity with the equipment. They should also be instructed in how and where the various items of equipment should be used in an emergency and how access to the equipment can be gained.

### 5. INSPECTION AND MAINTENANCE

5.1 The contents of emergency lockers should be inspected and maintained on a regular basis and will be subject to examination by a Department surveyor during the annual survey for the issue of a passenger ship safety certificate.

Department of Transport  
Marine Directorate  
London WC1V 6LP  
November 1988

© Crown copyright 1988

---

---

## Emergency Information for Passengers on Passenger Ships of Classes III, IV, V, VI AND VI(A)

Notice to Owners, Operators, Builders, Masters, Officers and Ratings of Passenger Ships of Classes III to VI(A).

*This Notice should be read in conjunction with Notice No. M.1409.*

---

---

### 1. Introduction

1.1 Following the Formal Investigation into the loss of the *Herald of Free Enterprise*, Merchant Shipping Notice No. M.1316\* was issued. That Notice drew attention to legislation dealing with the emergency information which must be provided for passengers and applicable to passenger ships of Classes II, II(A) and III. It also gave guidance on how the legislation could be implemented. The Notice was intended primarily for passenger ships of Classes II and II(A) and although some of the recommendations were also considered to be appropriate for certain ships of Classes III to VI(A)† a need was identified for recommendations more relevant to smaller ships of these Classes. The purpose of this Notice, therefore, is to fill this need for the smaller ships of these latter Classes. The recent sinking of the Class V passenger ship *Marchioness* with heavy loss of life has underlined this need.

1.2 The content of passenger emergency instructions notices and announcements will depend on the size and type of ship concerned. For example, a Class III or IV ship which can carry 1000 passengers will need more information displayed and broadcast than a small Class VI(A) ship carrying 20 passengers. It may be found that, in the case of the former, the guidance given in M.1409 is applicable in full whereas, in the case of the latter, a few words from the person in charge and a simple notice will suffice.

### 2. Statutory Requirements

2.1 Statutory requirements relating to the provision of emergency information for passengers on ships of Classes III to IV(A) are as follows;

2.1.1 Regulation 4 of the MS (Emergency Information for Passengers) Regulations 1990 requires that on ships of Classes III to VI(A)

carrying more than 20 passengers be provided with a public address system. In ships of Classes IV to VI(A) carrying not more than 50 passengers in which the passengers have access to only one passenger compartment or space a portable loud hailer may be carried in lieu of providing a public address system.

2.1.2 Regulations 4(9) and 4(10) of the MS (Muster and Training) Regulations 1986 require that on all ships of Class III, (a) clear instructions to be followed in the event of an emergency be provided for every person on board, and (b) instructions on muster stations, essential actions to be taken in an emergency, and the method of donning a lifejacket be conspicuously displayed at muster stations and other passenger spaces.

2.1.3 Regulation 6(3) of the MS (Muster and Training) Regulations 1986 requires that on all ships of Class III where a muster of the passengers is not held on departure, the attention of the passengers be drawn to the emergency instructions required by regulation 4(9) and 4(10) referred to above.

2.1.4 Regulation 5(2) of the MS (Emergency Information for Passengers) Regulations 1990 requires that on ships of Classes IV to VI(A) passengers shall be given emergency information at the commencement of each voyage and that emergency instructions notices be displayed in each passenger compartment.

2.1.5 Regulation 6 of the MS (Emergency Information for Passengers) Regulations 1990 requires that on ships of Classes III to VI(A), other than open or partially decked ships of Classes V to VI(A), all doors used for exits to open decks and all emergency escapes be clearly marked to indicate their purpose.

---

\* This Notice has been revised and reissued as M.1409.

† Passenger ships of Classes III to VI(A) are defined in the Merchant Shipping (Fire Protection) Regulations 1984.

### 3. Public Address System

3.1 When a public address system or portable loud hailer is provided such means should be used to inform the passengers of the action they should take in the event of an emergency which could lead to the ship being abandoned. This information, detailed in section 6, should be given either prior to or immediately on leaving the berth. An example of such an announcement is given at Annex 2 to this Notice. In the case of ships of Classes IV, V and VI which operate a waterbus or regular ferry service of short duration where compliance with regulation 5(2) of the MS (Emergency Information for Passengers) Regulations 1990 would result in very frequent broadcasting of the safety message, or where passengers are regular users of the service, other arrangements will be considered by the Department. For example, drawing attention on the public address system or by other means to safety notices displayed on the back of seats where all the passengers are seated, or to safety notices widely displayed in the passenger spaces where passengers are not seated.

3.2 The speakers in the public address system must be so located that broadcasts will be audible in all public spaces, including open decks, to which passengers have access.

3.3 A public address system should be powered from the main source of electrical power and from an alternative source of electrical power situated in a location remote from the main source.

3.4 Where a public address system or loud hailer is not provided the emergency information should be given by portable loud hailer.

### 4. Marking of Exits and Emergency Escapes

4.1 All doors leading from passenger spaces to open decks and all emergency escapes must be clearly marked with a sign using the word "EXIT" or the words "EMERGENCY ESCAPE DOOR/WINDOW" as appropriate. These signs should be legible at all times by means of the main or artificial lighting. In ro/ro passenger ships of Classes III to VI(A) the signs should be legible under supplementary lighting conditions.

4.2 Where possible the sign should be located over the door, window or escape. Where a door is not readily visible from within the space it serves a further sign should be provided to indicate the direction in which the door lies. Signs should not be on doors except in cases where a door is never in the open position when the ship is in service. Signs should be composed of white or light coloured letters on a green background

and on ships not provided with supplementary emergency lighting the signs should be made of a photoluminescent material.

### 5. Passenger Emergency Instructions Notices

5.1 Such notices are required to be displayed in each passenger compartment. The number to be displayed will depend on the layout of the compartments and the service the ship is engaged in (see paragraph 3.1). On some services it may also be appropriate to provide notices in terminals or waiting rooms. The information provided in a notice should include:

5.1.1 the method to be used to inform passengers that an emergency has occurred;

5.1.2 the action they will be required to take;

5.1.3 and how to use the life-saving equipment; and

5.1.4 how to don a lifejacket where lifejackets are carried.

5.2 Lifejacket donning information may be given separately and on ships with a small crew donning information should be provided in the form of posters located at the lifejacket stowage positions. Where lifejackets are stowed beneath the seats donning information should be provided on the backs of the seats.

5.3 An example of a passenger emergency instructions notice is given in Annex 1 to this Notice.

### 6. Passenger Emergency Instructions Announcement

6.1 The announcement required to be made at the commencement of each voyage should contain as a minimum:

6.1.1 the method to be used to inform passengers that an emergency has occurred;

6.1.2 the type of life-saving appliances on board;

6.1.3 action to take in event of an emergency;

6.1.4 how to use the life-saving appliances.

6.2 Announcements should be made in a clear and simple manner bearing in mind that in some services a significant number of foreign tourists may be carried on occasions. Announcements should be brief compatible with the need to convey sufficient information to assist all concerned in the event of an emergency leading to abandonment. Announcements should be

prefaced by a special signal followed by a request for everyone's attention. It should be ensured that no other announcement or music is allowed to be broadcast while the passenger emergency instructions announcement is being made.

6.3 An example of such an announcement is given in Annex 2 to this Notice.

## 7. General

7.1 Operators of ships of Classes III to VI(A) should consider each of their ships individually and determine whether the guidance in this Notice or M.1409 is appropriate. They should also determine what information should be displayed and announced (see section 5 and 6). Guidance on this matter should be sought from a Department Surveyor when a ship is being surveyed for the issue of its passenger certificate.

7.2 In the case of passenger ships of Classes III to VI(A) the number of crew members is often small and it is important that this point is taken into account by

operators of these ships when emergency procedures are being considered. In some cases this may involve active participation of some of the able bodied passengers under the direction of crew members, particularly at the abandon ship stage. The need for crew members to be readily recognisable in an emergency is important and consideration should be given to the provision of some distinguishing clothing, headwear, distinctive marking on lifejackets, loose covers worn over clothing or lifejackets, armbands, etc. Operators should also keep in mind the problems associated with disco and party cruises where an excessive consumption of alcohol may affect the ability of some of the passengers to help themselves in the event of a serious emergency occurring.

7.3 In-water support equipment, i.e. lifebuoys and buoyant apparatus, should be conspicuous and care taken that the primary function of buoyant apparatus is clearly apparent, i.e. that its use as lifesaving equipment is as apparent as or more apparent than its use as seating. Where lifejackets are carried, lifejacket lockers should be conspicuously marked.

Department of Transport  
Marine Directorate  
London WC1V 6LP  
April 1990

© Crown copyright 1990

## EXAMPLE

## EMERGENCY INSTRUCTIONS FOR PASSENGERS

## Please Read and Take Careful Note of the Contents of This Notice

1. In the event of an emergency you will be informed over the public address system\*/by means of a signal on the ship's whistle\*/by sounding of the alarm bells\*/by the person in charge\*. The signal on the whistle and/or the alarm bells will be;

Seven or more short blasts followed by one prolonged blast.



Remain calm and follow instructions.

2. In the event of the ship having to be abandoned you will be instructed by the Master to leave the compartment in which you are located using the nearest accessible exit which is clearly marked. Enter the water.

3. When in the water hold one of the grablines on a life buoy/buoyant apparatus\* Each lifebuoy can support two persons and each buoyant apparatus can support [ ]† persons.

---

\* As Appropriate.

† Insert appropriate number.

## EXAMPLE

## EXAMPLE OF EMERGENCY INSTRUCTION BROADCAST

1. **Special Signal**
2. Ladies and gentlemen, please listen very carefully to the following safety announcement.
3. In the event of an emergency you will be informed by means of an announcement\*/a signal consisting of seven or more short blasts followed by one prolonged blast on the ship's whistle and/or the alarm bells\*/by a crew member\*.
4. The vessel is equipped with buoyant apparatus and lifebuoys which can be manually launched or will float-free in the event of the vessel sinking.
5. In the event of an emergency requiring evacuation you will be instructed by the Master to proceed to the nearest accessible exit and to enter the water. All exits are clearly marked.
6. When in the water take hold of one of the grablines on a lifebuoy or buoyant apparatus. Each lifebuoy will support two persons and each buoyant apparatus [ ]\* persons.
7. Thank you for your attention.

---

\* As appropriate.

---

---

## Emergency Information for Passengers

Notice to Owners and Operators of Passenger Ships, Masters, Officers, Ratings and Shipbuilders

*This Notice Supersedes Notice No. M.1316*

---

---

### 1. Introduction

1.1 The first purpose of this Notice is to draw the attention of all concerned to the relevant statutory requirements on this subject and to make specific recommendations on the provision of safety information in the form of broadcasts, notices and signs for use by passengers in an emergency. The second purpose is to remind owners and operators of passenger ships of the need to ensure that adequate measures are taken to inform passengers of the procedures which would be adopted in the event of an emergency situation arising, and that it is particularly important that this information is communicated to passengers prior to, or on departure from port.

1.2 The recommendations in this Notice are primarily intended for passenger ships of Classes I, II and II(A).<sup>\*</sup> Recommendations intended for smaller passenger ships of Classes III to VI(A)<sup>\*</sup> are found in M.1386. However, some or all of the recommendations in this Notice may be appropriate for larger ships of Classes III, IV and V carrying large numbers of passengers. Operators, designers and builders of such ships should examine these two Notices carefully and apply the recommendations which are most appropriate for a particular ship.

1.3 This Notice includes recommendations on the following subject matter:

1.3.1 the provision and description of “muster station signs”, “muster station direction signs”, “exit signs”, “emergency escape signs” and “deck identification signs”.

1.3.2 “passenger emergency instructions notices” provided at muster stations, in passenger cabins and other passenger spaces, and

1.3.3 means of drawing attention of passengers to the emergency procedures information.

### 2. Statutory Requirements

2.1 There are currently seven specific statutory requirements relating to the provision of signs, emergency instructions and public address systems to assist passengers in the event of an emergency. These requirements are as follows:

2.1.1 Regulation 128(5) of the MS (Passenger Ship Construction) Regulations 1980 requires that on ships of Class I built before 1 September 1984 continuously illuminated signs be provided in passageways and stairways indicating the direction to muster stations.

2.1.2 Regulation 76(5) of the MS (Passenger Ship Construction and Survey) Regulations 1984 requires that on ships of Classes I, II and II(A) (whose keels were laid on or after 1 September 1984) continuously illuminated signs be provided in passageways and stairways indicating the direction to muster stations. The provision of such information is equally important on ships of Classes II and II(A) whose keels were laid before that date and on certain ships of other Classes and it is recommended that similar provision should be made on such ships.

2.1.3 Regulation 6 of the MS (Emergency Information for Passengers) Regulations 1990 requires that on all passenger ships (other than open or partially decked ships of Classes V, VI and VI(A)) all doors used for exits to open decks and all emergency escapes be clearly marked to indicate their purpose.

2.1.4 Regulation 4 of the MS (Emergency Information for Passengers) Regulations 1990 requires that passenger ships (with certain exceptions) not already required to be provided with a public address system, be provided with such a system.

<sup>\*</sup> Passenger ships of Classes I to VI(A) are defined in the Merchant Shipping (Fire Protection) Regulations 1984.

2.1.5 Regulations 4(9) and 4(10) of the MS (Muster and Training) Regulations 1986 require that on all ships of Classes II, II(A), and III, (a) clear instructions to be followed in the event of an emergency be provided for every person on board, and (b) that instructions on muster stations, essential actions to be taken in an emergency, and the method of donning a lifejacket be posted in passenger cabins and conspicuously displayed at muster stations and other passenger spaces.

2.1.6 Regulation 6(3) of the MS (Muster and Training) Regulations 1986 requires that on all ships of Classes II, II(A) and III where a muster of the passengers is not held on departure, the attention of the passengers be drawn to the emergency instructions required by regulations 4(9) and 4(10) referred to above.

2.1.7 Regulation 5(1) of the MS (Emergency Information for Passengers) Regulations 1990 requires that on ships of Class I, if a muster is not held on departure, the attention of passengers be drawn to the emergency instructions referred to in paragraph 2.1.5.

### **3 Signs**

#### **3.1 General**

3.1.1 Since the majority of passengers, particularly on ships of Classes II and II(A) will have very little knowledge of the layout of the ship on which they are travelling or of the purpose or location of the Muster Stations, it is essential to ensure that the Muster Stations are readily identifiable, that their purpose is made known and that the routes to the Muster Stations are clearly marked. It is also important that normal and emergency exits from enclosed spaces are clearly indicated. The use of the signs described in this section should therefore be of great assistance to passengers in this respect.

3.1.2 Care should be taken to place the signs referred to in this Notice in prominent and continuously illuminated positions and clear of other signs.

#### **3.2 Muster Station Sign**

3.2.1 While there is no specific statutory requirement to display a muster station sign such a sign has been adopted by the International Maritime Organisation and its use is strongly recommended in Merchant Shipping Notice No. M.1293. The sign is illustrated in Annex 1 to this Notice.

3.2.2 The sign is square in shape with the component parts of the muster station symbol in white on a green background. The sign consists of an arrow at each corner pointing inwards to a symbol for a family group at the centre of the sign (see Annex 1).

3.2.3 It is recommended that the dimensions of the symbol be 480 x 480 mm unless the size of the muster station or the location of the sign is such that a smaller size or sign would be appropriate. The dimensions of the sign should where possible be preferred dimensions as listed in Amendment No. 1 to BS 5378: Part 2: 1980 (Safety signs and colours Part 2. Specification for colorimetric and photometric properties of materials). The design and colour of the sign should comply with BS 5378: Part 1: 1980 (Safety Signs and Colours Part 1. Specification for colour and design).

3.2.4 Where the muster station is identified by a number (or letter) the size of the number (or letter) should be compatible with the size of the muster station symbol.

3.2.5 Muster station signs should be so located in muster stations that they are readily apparent to passengers and the muster stations themselves clearly identifiable.

#### **3.3 Muster Station Direction Sign**

3.3.1 This sign, the use of which is strongly recommended in Merchant Shipping Notice No. M.1293 consists of the sign for a muster station in combination with an arrow. The colour of the symbol for the arrow is white on a green background. It is recommended that the dimensions for each of the symbols be 180 x 180 mm or 360 x 180 mm for a combined sign unless the location of the sign is such that a smaller size of sign would be appropriate. The dimensions of the sign should where possible be preferred dimensions as recommended in paragraph 3.2.3.

3.3.2 Muster station direction signs should be provided in the alleyways of passenger cabin spaces, on stairways leading to the muster stations, in public rooms not used as muster stations, in entrance halls and spaces linking public rooms and on outside decks in the vicinity of doors giving access to muster stations.

3.3.3 While it is important that the routes to muster stations are prominently marked, it is of course equally important that these routes are kept clear at all times and not allowed to be used by passengers as places in which to leave luggage and other belongings.

### 3.4 *Exit and Emergency Escape Signs*

3.4.1 All doors provided for passenger use leading from passenger spaces to open decks must be clearly indicated with one or more signs marked "EXIT". Where possible one sign should be over the door but where the door is not readily visible from within the space it serves a further sign should be provided to indicate the direction in which the door lies. In ships of Classes I, II and II(A) the signs should be capable of being illuminated by the ship's emergency lighting system. In Ro/Ro passenger ships of Classes I, II and II(A) such signs should be legible under supplementary emergency lighting conditions. The sign should be composed of white letters on a green background.

3.4.2 Doors, windows, side scuttles and other openings provided for emergency escape purposes only, should be clearly marked "EMERGENCY ESCAPE WINDOW/DOOR" as appropriate and should be designed and capable of being seen as described above for exit signs.

### 3.5 *Deck Identification Signs*

3.5.1 Each deck in the passenger spaces should be capable of being readily identified eg by a letter, number or name. The relevant signs should be located at a convenient place close to each entrance to the space. In public rooms a deck identification sign should be clearly visible.

3.5.2 The colours used in the signs should contrast with the colour of the panelling to which they are attached.

3.5.3 The display of simple plans showing "you are here" positions and decks to which passengers have access, will also be of assistance to passengers in identifying decks.

## 4. **Passenger Emergency Instructions Notices**

4.1 Such notices are required to be provided in passenger cabins, at muster stations and in other passenger spaces and as a minimum must include information on muster stations, essential action to take in an emergency and the method of donning lifejackets. The instructions may be provided on one notice or alternatively, in two parts with the instructions on donning lifejackets being provided in the form of the lifejacket manufacturer's donning instructions. The instructions should be in English followed by any other language or languages appropriate to the principal nationalities carried on the route on which the ship is operating.

4.2 The passenger emergency instructions notice should be located in suitable positions in muster stations and where possible close to the muster station signs. Such notices should also be placed in other public passenger spaces not used as muster stations and should be kept well clear of other non-safety signs and posters.

4.3 An example of a passenger emergency instructions notice is given in Annex 1 to this Notice.

## 5. **Public Address Systems**

5.1 Except where otherwise provided in the Merchant Shipping (Fire Protection) Regulations 1984, broadcasts made on a public address system should be capable of being heard in all public spaces, including open decks, to which passengers have access.

5.2 A public address system should be powered from the main source of electrical power, and on ships where there is no requirement for the system to be powered from an emergency source it should also be powered from an alternative source of electrical power situated in a location remote from the main source.

## 6. **Means of Drawing Passengers' Attention to Passenger Emergency Instructions Notices**

6.1 It is most important to draw the attention of the passengers to the location and contents of the passenger emergency instructions notices and to encourage the passengers to read the notices. This is particularly important in Class I ships where a muster is not held on departure. There are various ways of encouraging the passengers to read the notices although the most effective way will be by means of the ship's public address system. The announcements should be made after all the passengers have boarded and either prior to or immediately on departure from the berth. Since it is often difficult to gain the full attention of passengers at this early stage in the voyage it is recommended that this type of announcement be prefaced by a special signal when the public address system is used and followed by a request for everyone's attention. Announcements should be made in English followed by languages appropriate to the principal nationalities of passengers carried on a particular route. Such announcements should be relatively brief compatible with the need to convey sufficient information to the listener to enable an orderly muster of the passengers to take place if this should become necessary. It should be ensured that no other announcement or music is allowed to be broadcast while the passenger emergency instruction announcement is being made.

6.2 An example of an announcement for this purpose is given in Annex 2 of this Notice.

6.3 Announcements on board the ship should be supplemented by other means appropriate to the ship and voyage to ensure that as many passengers as possible have their attention drawn to the passenger emergency instructions notices. This can include the showing of video programmes on board or in the shore terminal, inserting in the ticket folder a page containing emergency procedures information, including information in magazines and brochures published for passengers, making announcements in the shore terminal that passengers should familiarise themselves with the contents of the notices on board, etc.

## 7. Conclusion

The overall aim in providing the foregoing signs, notices and instructions should be to ensure that the majority of the passengers will be sufficiently well informed to know that:

7.1 proper contingency plans exist for their evacuation from the ship if this should ever become necessary;

7.2 in an emergency situation they are expected to proceed to, or remain in, a muster station and conduct themselves in an orderly manner;

7.3 when assembled in a muster station they will be issued with a lifejacket by a member of the crew if not already so provided;

7.4 they should follow the instructions of the member of the crew present in the muster station; and

7.5 in the event of a sudden disaster where the normal evacuation procedures cannot be put into effect, they will be able to find their way out of the enclosed spaces by the normal exits or emergency escapes.

Department of Transport  
Marine Directorate  
London WC1V 6LP  
April 1990

© Crown copyright 1990

## EXAMPLE

## EMERGENCY INSTRUCTIONS FOR PASSENGERS

Please Read and Take Careful Note of the Contents of This Notice

### 1. GENERAL EMERGENCY ALARM SIGNAL

In the event of an emergency the following signal will be sounded on the ship's whistle and on the alarm bells:

Seven or more short blasts followed by one prolonged blast.



### 2. ACTION ON HEARING GENERAL EMERGENCY ALARM SIGNAL

If this signal is sounded and you are not already in a Muster station, proceed calmly to the nearest Muster Station\*/to your cabin\*, dress warmly, collect your lifejacket and follow the direction signals to your Muster station.

[If you are in a cabin when the signal is heard dress warmly, collect your lifejacket from [ ]\* and follow the direction signs to your Muster Station]†.

### 3. MUSTER STATIONS

A Muster Station is a space where passengers will be required to assemble in the event of an emergency. Muster Stations are marked by the sign shown below and with a number\*/letter\*. On this ship the Muster Stations are located in\* [

] The direction signs to Muster Stations consist of the Muster Station sign and an arrow pointing in the appropriate direction.



### 4. ACTION ON ARRIVAL IN MUSTER STATION

On arrival in a muster station, (or if you are already located in a muster station), you will be issued with a lifejacket by a member of the crew [unless you have collected a life jacket from your cabin]\* and, as necessary, instructed in how it is to be worn. Child lifejackets are available for smaller children. Please see accompanying instructions on method of donning a lifejacket.

### 5. SUBSEQUENT ACTION

Remain calm and follow the instructions of the crew members in your muster station.

---

\* As appropriate.

† Include if cabin accommodation, and also include any additional information relevant to action to take when in a cabin.

**EXAMPLE****EXAMPLE OF EMERGENCY INSTRUCTION BROADCAST****1. Special Signal**

2. “Ladies and gentlemen, would you please listen very carefully to the following safety announcement.
3. Your attention is drawn to “the passenger emergency instruction notices” which are displayed in the [cabins,]\* Muster Stations, and in other spaces.
4. These notices include the location of Muster Stations, that is, the areas where passengers should assemble in the event of an emergency, the method of donning a lifejacket and a description of the General Emergency Alarm Signal.
5. This Signal consists of seven or more short blasts followed by one prolonged blast on the ship’s whistle, then by a similar signal on the alarm bells.
6. If this Signal is sounded and you are not already in a Muster Station you should proceed to the nearest Muster Station\*,/to your cabin\*, dress warmly, collect your lifejacket and then proceed to your Muster Station.
7. The Muster Stations on this ship are located in [ ]\*. The Muster Stations can be identified by a square green and white sign and an arrow in each corner pointing inwards to a symbol depicting a family group.
8. At a Muster Station a crew member will issue you with a lifejacket and instruct you how it is to be worn. You should remain calm and follow the instructions of the crew members in your Muster Station”.

---

\* As appropriate.

---

---

## Carriage of Additional Lifejackets

Notice to Builders, Owners, Skippers and Crew of Fishing Vessels

---

---

1. The Report of the Court of Formal Investigation into the circumstances surrounding the loss of the MV "LOVAT" recommended that "an additional supply of lifejackets should be kept in some such position as the bridge to cater for situations in which it is not possible for all the crew to collect their lifejackets from their accommodation".\*

2. The Department in accepting the views of the Court and bearing in mind the restricted storage space available in the smaller fishing vessels issued appropriate advice in Merchant Shipping Notice M.873 (no longer extant). The advice previously given in that Notice remains valid however and the Department therefore continues to recommend that:

- (a) The recommendation should extend to all sea going fishing vessels having a registered length of 12 metres and over and carrying a crew of eight or more persons, which are subject to the provisions of the Fishing Vessels (Safety Provisions) Rules 1975.†
- (b) The number of additional lifejackets should be related to the number of persons that the vessel is certificated to carry as follows:

- (i) more than 16 persons—additional lifejackets for not less than 25 per cent;
- (ii) between eight and 16 persons—not less than two additional lifejackets;
- (iii) less than eight persons—no additional lifejackets required.

(c) The additional lifejackets should be of the same type as supplied to the vessel to meet statutory requirements and should be stowed at or near the normal embarkation positions, except in the cases of smaller vessels which carry lifejackets to meet statutory requirements in boxes on deck. In these latter cases bridge stowage for additional lifejackets might be appropriate, or alternative positions should be agreed with the surveyor.

(d) A suitable unlocked clearly marked, dry stowage position should be provided.

(e) The Department recommends that on vessels which carry less than eight persons at least two of the statutory lifejackets be stowed, if practicable, in the wheelhouse.

Department of Transport  
Marine Directorate  
London WC1V 6LP  
April 1990

---

\* Report of Court No 8066 published in May 1977—HMSO

† SI 1975/330 SI 1977/313

---

---

## Life-Saving Appliances—The Provision of Rescue Boats on Ships Fitted with Free Fall Lifeboats

Notice to Shipbuilders, Shipowners, Masters and Ships' Officers

---

---

1. The Merchant Shipping (Life-Saving Appliances) Regulations 1986 (SI 1986 No. 1066) allow the fitting of free fall totally enclosed lifeboats on ships of Class VII, VII(T), VIII, VIII(A), VIII(T), VIII(A)(T) and IX. Under the same regulations any lifeboat may be accepted as a rescue boat provided that it also complies with the requirements of a rescue boat.
2. Trials of free fall lifeboats being used as rescue boats have shown that they cannot be recovered safely in conditions other than calm. The Department has concluded that free fall lifeboats are not acceptable as rescue boats.
3. The Department recommends that existing and new ships fitted with free fall lifeboats should be provided with a rescue boat and launching arrangements which comply with the requirements for rescue boats.

Department of Transport  
Marine Directorate  
London WC1V 6LP  
October 1992

© Crown copyright 1993



MARINE SAFETY AGENCY

---

---

## Minimum Training Requirements for Personnel Nominated to Assist Passengers in Emergency Situations

Notice to Owners, Managers, Masters and Crew of Passenger Ships

---

---

### Introduction

1. On 4 November 1993, the 18th Assembly of the International Maritime Organisation adopted Resolution A770 (18) on the subject of minimum training requirements for personnel nominated to assist passengers in emergency situations on passenger ships. A copy of this Resolution is attached as an Annex to this Notice. Its contents are not mandatory but the advice it contains is endorsed by the MSA.
2. Owners, Managers and Officers are recommended to ensure that crew members nominated to assist passengers in emergency situations are trained in accordance with the Resolution.
3. The contents of this M. Notice should be read in conjunction with the Merchant Shipping (Musters and Training) Regulations 1986 (S.I. 1071 of 1986) as amended in 1993 (S.I. 3231 of 1993) and Merchant Shipping Notices Nos. M.1217, M.1396 and M.1441.
4. Where suitable training is undertaken ashore, this would usefully be supplemented by shipboard training because familiarity with a specific ship and knowledge of the locations of various equipment and escape routes on board is invaluable.

Marine Safety Agency  
Spring Place  
105 Commercial Road  
Southampton SO15 1EG  
November 1994

© Crown Copyright 1994

*Safe Ships Clean Seas*

IMO

A 18/Res. 770

Adopted on 4 November 1993

**Recommendation on Minimum Training Requirements for Personnel nominated to assist  
Passengers in Emergency Situations on Passenger Ships**

**1. General**

1.1 Personnel nominated on muster lists to assist passengers in emergency situations should receive additional training to enable them to perform their duties properly. The number of trained persons should always be sufficient to assist the total number of passengers who may be on board at anyone time. The number of trained persons should be included on the ship's safe manning document.

1.2 Where training is given in a shore-based training course, it should be supplemented by shipboard training before assuming the duties referred to in 1.1. The training should be to the satisfaction of the Administration. Administrations should establish some means of ensuring that crew members maintain continued proficiency through periodic refresher training, drills or related work experience.

1.3 Communication skills should be sufficient to assist passengers during an emergency, taking into account the following criteria:

- .1 the language or languages appropriate to the principal nationalities of passengers carried on a particular route;
- .2 the likelihood that an ability to use elementary English vocabulary for basic instructions can provide a means of communicating with a passenger in need of assistance whether or not the passenger and crew member share a common language;
- .3 the possible need to communicate during an emergency by some other means (e.g. by demonstration, or hand signals, or calling attention to the location of instructions, muster stations, life-saving devices or evacuation routes) when verbal communication is impractical;
- .4 the extent to which complete safety instructions have been provided to passengers in their native language or languages; and
- .5 the languages in which emergency announcements may be broadcast during an emergency or drill to convey critical guidance to passengers and to facilitate crew members in assisting passengers.

1.4 The training should include but not necessarily be limited to the following items.

**2. Theoretical**

2.1 Awareness of life-saving appliance plans and fire control plans. Knowledge of muster lists and emergency instructions including:

- .1 general alarms and procedures for mustering of passengers, and
- .2 areas of responsibility with emphasis on "own section".

2.2 General layout of the ship with special emphasis on location of muster and embarkation stations, accesses and escape routes.

2.3 Location and use of emergency equipment relevant to the duties in 1.1 with emphasis on "own section" and escape routes therefrom.

2.4 Location of adult and infant lifejackets.

2.5 Location of other evacuation supplies, e.g. blankets, to be taken to survival craft.

2.6 Elementary first aid and transportation of casualties.

## 2.7 Communication:

- .1 the use of internal communication systems;
- .2 raising the alarm;
- .3 alerting the passengers; and
- .4 reporting and notification.

## 2.8 Evacuation:

- .1 the use of passenger lists or counts;
- .2 the alarm signals ;
- .3 mustering; importance of keeping order and panic avoidance procedures;
- .4 emergency exits;
- .5 evacuation equipment;
- .6 control of passengers in corridors, staircases and passage ways;
- .7 maintenance of escape routes clear of obstructions ;
- .8 assistance en route to muster and embarkation station;
- .9 methods available for evacuation of disabled persons and persons needing special assistance;
- .10 restrictions on the use of elevators;
- .11 search of accommodation spaces; and
- .12 ensuring that the passengers are suitably clothed and have donned their lifejackets correctly.

## 2.9 Fire situations:

- .1 fire detection and initial containment;
- .2 raising the alarm;
- .3 danger of smoke inhalation; and
- .4 breathing protection.

## 2.10 Abandon ship situations:

- .1 correct use of individual survival equipment, e.g., lifejackets, immersion suits, lifebuoys, light and smoke signals, etc; and
- .2 need for assistance to special cases.

## **3. Practical**

- 3.1 Familiarization by means of repeated organized guided tours on board.
- 3.2 Repeated participation in fire drills and lifeboat drills including transportation of simulated casualties.
- 3.3 Repeated exercise in use of equipment such as donning of lifejackets and appropriate protective clothing.
- 3.4 Repeated exercise in use of internal communication systems.
- 3.5 Repeated exercises in evacuation.



Maritime and Coastguard Agency

## MSN 1676 (M)

### **The Merchant Shipping (Life-Saving Appliances for Ships Other Than Ships of Classes III to VI(A)) Regulations 1999**

### **The Merchant Shipping (Life-Saving Appliances for Passenger Ships of Classes III to VI(A)) Regulations 1999**

Notice to Shipowners, Certifying Authorities, Shipbuilders, Shiprepairers, Ship Masters and Surveyors

#### *Summary*

This Notice advises all Shipowners, Shipbuilders, Ship Repairers, Ship Masters, Certifying Authorities and Surveyors of the new 1999 Life-Saving Appliances Regulations.

#### Key Points:-

- This Notice forms an integral part of the Merchant Shipping (Life-Saving Appliances for Ships Other than Ships of Classes III to VI(A)) Regulations 1999; and the Merchant Shipping (Life-Saving Appliances for Passenger Ships of Classes III to VI(A)) Regulations 1999.
- Schedules contained in this Notice are invoked by those Regulations and are therefore a statutory obligation.

#### **List of Schedules**

- Schedule 1: General Requirements for all life-saving appliances
- Schedule 2: Lifeboats, rigid rescue boats and fast rescue boats
- Part 1 General
  - Part 2 Lifeboats
  - Part 3 Partially enclosed lifeboats
  - Part 4 Totally enclosed lifeboats
  - Part 5 Lifeboats with self-contained air support system
  - Part 6 Fire-protected lifeboats
  - Part 7 Rigid rescue boats
  - Part 8 Rigid inflated rescue boats
  - Part 9 Free-fall lifeboats
  - Part 10 Fast rescue boats, rigid and rigid inflated

- Schedule 3: Inflated rescue boats and inflated boats
- Part 1 General
  - Part 2 Inflated rescue boats
  - Part 3 Inflated boats (Non-SOLAS)
- Schedule 4: Liferafts
- Part 1 General
  - Part 2 Inflatable liferafts
  - Part 3 Rigid liferafts
  - Part 4 Open reversible liferafts
  - Part 5 Inflatable liferafts (Non-SOLAS)
  - Part 6 Liferaft equipment (SOLAS)
  - Part 7 Automatic release hooks
  - Part 8 Float free arrangements
  - Part 9 Liferaft lights
- Schedule 5: Marine escape systems and means of rescue system
- Part 1 Marine evacuation system
  - Part 2 Training
  - Part 3 Means of rescue system
- Schedule 6: Launching appliances and embarkation ladders
- Part 1 General
  - Part 2 Lifeboat and rescue boat launching appliances
  - Part 3 Liferaft launching appliances
  - Part 4 Inflated boat launching appliances
  - Part 5 Embarkation ladders
- Schedule 7: Pyrotechnic signals and line throwing appliances
- Part 1 General
  - Part 2 Rocket parachute flares
  - Part 3 Hand flares
  - Part 4 Buoyant smoke signals
  - Part 5 Line throwing appliances
  - Part 6 Information, instruction and stowage
- Schedule 8: Lifebuoys and attachments
- Part 1 General
  - Part 2 Lifebuoys (SOLAS)
  - Part 3 Lifebuoys (610 millimetres)
  - Part 4 Lifebuoy self-igniting lights
  - Part 5 Lifebuoy self-activating smoke signals
  - Part 6 Lifebuoy buoyant lifelines
- Schedule 9: Lifejackets and attachments
- Part 1 General
  - Part 2 Inherently buoyant lifejackets (over 32 kilogrammes)
  - Part 3 Inherently buoyant lifejackets (under 32 kilogrammes)
  - Part 4 Inflatable lifejackets
  - Part 5 Inflatable Civil Aviation Authority lifejacket
  - Part 6 Buoyancy aids

- Schedule 10: Requirements for immersion suits, anti-exposure suits and thermal protective aids
- Part 1 Immersion suits  
Part 2 Anti-exposure suits  
Part 3 Thermal protective aids
- Schedule 11: General emergency alarm systems and public address systems
- Part 1 General emergency alarm systems  
Part 2 Public address systems
- Schedule 12: Buoyant apparatus
- Schedule 13: Survival craft equipment and rations
- Part 1 First aid outfits  
Part 2 Food rations  
Part 3 Fresh water  
Part 4 Sea-anchors
- Schedule 14: Training manuals and instructions for on-board maintenance
- Part 1 Training manuals  
Part 2 Instructions for on-board maintenance
- Schedule 15: Carriage of two-way VHF radiotelephone sets - exempting conditions
- Schedule 16: Symbols relating to life-savings appliances and arrangements

In this Merchant Shipping Notice –

- (1) a reference to a numbered paragraph is, unless otherwise stated, a reference to the paragraph of that number in that Part;
- (2) a reference to a numbered section is, unless otherwise stated, a reference to the section of that number in that Part;
- (3) a reference to a numbered Part is, unless otherwise stated, a reference to the Part of that number in that Schedule;
- (4) a reference to a numbered Schedule, is unless otherwise stated, a reference to the Schedule of that number in the Merchant Shipping Notice;
- (5) a reference to the Small Passenger Ships Regulations means a reference to the Merchant Shipping (Life-saving Appliances for Passenger Ships of Classes III to VI(A)) Regulations 1999;
- (6) a reference to the Other Ships Regulations means a reference to the Merchant Shipping (Life-saving Appliances for Ships Other Than Ships of Classes III to VI(A)) Regulations 1999.

**SCHEDULE 1****GENERAL REQUIREMENTS FOR ALL LIFE-SAVING APPLIANCES**

1. Unless expressly provided otherwise, all life-saving appliances shall –
  - 1.1 be constructed with proper workmanship and materials;
  - 1.2 not be damaged in stowage in the air temperature range -30°C to +65°C;
  - 1.3 be capable of operating in the sea water temperature range of -1°C to +30°C;
  - 1.4 be rot-proof, corrosion-resistant, and not be unduly affected by seawater, oil or fungal attack;
  - 1.5 be resistant to deterioration from exposure to sunlight;
  - 1.6 be of a highly visible colour on all parts where this will assist detection;
  - 1.7 be fitted with retro-reflective material where it will assist in detection and the dimensions and location of the material shall be sufficient for this purpose;
  - 1.8 be capable of satisfactory operation in a sea environment;
  - 1.9 be clearly marked with approval information including the Administration which approved it, and any operational restrictions;
  - 1.10 where applicable, be provided with electrical short circuit protection to prevent damage or injury; and
  - 1.11 life-saving appliances which are subject to deterioration with age shall be marked with a means for determining their age or the date by which they must be replaced. Permanent marking with a date of expiry is the preferred method of establishing the period of acceptability. Batteries not marked with an expiry date may be used if they are replaced annually, or in the case of a secondary battery or accumulator, if the condition of the electrolyte can be readily checked.

## SCHEDULE 2

### LIFEBOATS, RIGID RESCUE BOATS AND FAST RESCUE BOATS

#### PART 1 – GENERAL

##### *Definitions*

1. In this Schedule the following definition applies –

“Length of lifeboat or rigid rescue boat or fast rescue boat” means the length of the boat in metres from the inside of the shell at the top of the stem to the corresponding point at the top of the stern post; in the case of a boat with a square stern the length is measured to the inside of the top of the transom.

##### *General*

2. Lifeboats, rigid rescue and fast rescue boats shall comply with the requirements of Schedule 1 and, in addition, with the requirements of this Part.

##### *Construction*

- 3.1 Boats shall be properly constructed and shall be of such form and proportions that they have ample stability in a seaway and sufficient freeboard when loaded with their full complement of persons and equipment. Boats shall have rigid hulls and shall be capable of maintaining positive stability when in an upright position in calm water and loaded with their full complement of persons and equipment and holed in any one location below the waterline, assuming no loss of buoyancy material and no other damage.
- 3.2 Boats shall be of sufficient strength to –
  - 3.2.1 enable them to be safely lowered into the water when loaded with their full complement of persons and equipment; and
  - 3.2.2 be capable of being launched and towed when the ship is making headway at a speed of 5 knots in calm water.
- 3.3 Hulls and rigid covers shall be fire-retardant or non-combustible.
- 3.4 Seating shall be provided on thwarts, benches or fixed chairs which are constructed so as to be capable of supporting:
  - 3.4.1 a static load equivalent to the number of persons each weighing 100 kilogrammes for which spaces are provided in compliance with the requirements of Part 2 paragraph 2.3, Part 5 paragraph 2 or Part 8 paragraph 2.1 as appropriate;
  - 3.4.2 a load of 100 kilogrammes in any single seat location when a lifeboat to be launched by falls is dropped into the water from a height of at least 3 metres; and
  - 3.4.3 a load of 100 kilogrammes in any single seat location when a free-fall lifeboat is launched from a height of at least 1.3 times its free-fall certification height.

- 3.5 Except for free-fall lifeboats, each boat shall be of sufficient strength to withstand a load, without residual deflection on removal of that load –
- 3.5.1 in the case of boats with metal hulls, 1.25 times the total mass of the boat when loaded with its full complement of persons and equipment; or
- 3.5.2 in the case of other boats, twice the total mass of the boat when loaded with its full complement of persons and equipment.
- 3.6 Except for free-fall lifeboats, each boat shall be of sufficient strength to withstand, when loaded with its full complement of persons and equipment and fitted, where applicable, with skates or fenders-
- 3.6.1 a lateral impact against the ship's side at an impact velocity of at least 3.5 metres per second; and
- 3.6.2 also a drop into the water from a height of at least 3 metres.
- 3.7 Each seating position shall be clearly indicated in the boat.
- 3.8 Boats shall have a boarding ladder that can be used on either side of the boat to enable persons in the water to board the boat. The lowest step of the ladder shall be not less than 0.4 metres below the boat's light waterline and shall be weighted if of buoyant material.
- 3.9 The boat shall be so arranged that helpless people can be brought on board either from the sea or on stretchers.
- 3.10 Surfaces on which persons might walk shall have a non-skid finish.
- 3.11 Boats shall have inherent buoyancy or shall be fitted with inherently buoyant material, which shall not be adversely affected by seawater, oil or oil-products, sufficient to float the boat with all its equipment on board when flooded and open to the sea. Additional inherently buoyant material, equal to 280 newtons of buoyant force per person shall be provided for the number of persons the boat is permitted to accommodate. Buoyant material, unless in addition to that required above, shall not be installed externally to the hull of the boat.
- 3.12 All lifeboats shall be stable and have a positive GM value when loaded with 50 per cent of the number of persons the lifeboat is permitted to accommodate in their normal positions to one side of the centreline.
- 3.13 Under the condition of loading in paragraph 3.12 –
- 3.13.1 each lifeboat with side openings near the gunwale shall have a freeboard, measured from the waterline to the lowest opening through which the lifeboat may become flooded, of at least 1.5 per cent of the lifeboat's length or 100 millimetres, whichever is the greater; and
- 3.13.2 each lifeboat without side openings near the gunwale shall not exceed an angle of heel of 20 degrees and shall have a freeboard, measured from the waterline to the lowest opening through which the lifeboat may become flooded, of at least 1.5 per cent of the lifeboat's length or 100 millimetres, whichever is the greater.

### *Propulsion*

- 4.1 Except as permitted by paragraph 3.2 of Part 7 (for rigid rescue boats) every boat shall be powered by a compression ignition engine. No engine shall be used for any boat if its fuel has a flashpoint of 43°C or less (closed cup-test) and the engine shall –

- 4.1.1 be provided with either a manual starting system, or a power starting system with two independent rechargeable energy sources. Any necessary starting aids shall also be provided. The engine starting systems and starting aids shall start the engine at an ambient temperature of -15°C within 2 minutes of commencing the start procedure unless, having regard to the particular voyages in which the ship carrying the boat is constantly engaged, a different temperature is appropriate. The starting systems shall not be impeded by the engine casing, thwarts or other obstructions;
- 4.1.2 be capable of operating for not less than 5 minutes after starting from cold with the boat out of the water; and
- 4.1.3 be capable of operating when the boat is flooded up to the centreline of the crankshaft;
- 4.2 Unless the propeller is arranged so as to avoid its rotation constituting a danger to people in the water adjacent to it, the drive arrangement between the prime mover and the propeller shall be such that the propeller can be brought to rest without stopping the prime mover. Provision shall be made for ahead and astern propulsion of the craft.
- 4.3 The exhaust pipe shall be so arranged as to prevent water from entering the engine in normal operation and insulated as necessary.
- 4.4 Boats shall be designed with due regard to the safety of persons in the water and to the possibility of damage to the propulsion system by floating debris.
- 4.5 The engine, transmission and engine accessories shall be enclosed in a fire-retardant casing or other suitable arrangements providing similar protection. Such arrangements shall also protect persons from coming into accidental contact with hot or moving parts and protect the engine from exposure to weather and sea. Adequate means shall be provided to reduce engine noise. Starter batteries shall be provided with casings which form a watertight enclosure around the bottom and sides of the batteries. The battery casings shall have tight fitting tops which provide for necessary gas venting.
- 4.6 The engine and accessories shall be designed to limit electromagnetic emissions so that engine operation does not interfere with the operation of radio life-saving appliances used in the boat.
- 4.7 Means shall be provided for recharging all engine-starting, radio and searchlight batteries. Radio batteries shall not be used to provide power for engine starting. Means shall be provided for recharging boat batteries from the ship's power supply. The electric power supply connection from the ship to any boat shall be at a voltage not exceeding 55 volts direct current or 55 volts root mean square alternating current and shall be capable of being disconnected automatically at the embarkation station. Charging current may be supplied by means of a solar battery charger.
- 4.8 Water-resistant instructions for starting and operating the engine shall be provided and mounted in a conspicuous place near the engine starting controls.

### *Fittings*

- 5.1 Boats shall be provided with at least one drain valve fitted near the lowest point in the hull, which shall automatically open to drain water from the hull when the boat is not waterborne and shall automatically close to prevent entry of water when the boat is waterborne. Each drain valve shall be provided with a cap or plug to close the valve, which shall be attached to the boat by a lanyard, a chain, or other suitable means. Drain valves shall be readily accessible from inside the boat and their positions shall be clearly indicated.

- 5.2 Boats shall be provided with a rudder and tiller or other suitable means of steering. When a wheel or other remote steering mechanism is also provided the tiller or this means shall be capable of steering the boat in the case of failure of the steering mechanism. Except where the rudder and the tiller form part of an outboard engine the rudder shall be permanently attached to the boat and any tiller shall be permanently installed on or linked to the rudder stock. However if the boat has a remote steering mechanism the tiller may be removable and securely stowed near the rudder stock. The steering arrangements shall be arranged so as not to be damaged by operation of the release mechanism or the propeller.
- 5.3 Except in the vicinity of the rudder, propeller or outboard engine, suitable handholds shall be provided or a buoyant line shall be becketed around the outside of the boat, above the waterline and within reach of a person in the water.
- 5.4 Boats which are not self-righting when capsized shall have suitable handholds on the underside of the hull to enable persons to cling to the boat. The handholds shall be fastened to the boat in such a way that, when subjected to an impact sufficient to cause them to break away from the boat, they break away without damaging the boat.
- 5.5 Every boat to be launched by a fall or falls shall be fitted with a release mechanism complying with section 8.
- 5.6 Every lifeboat shall be fitted with a device to secure painter near its bow. The device shall be such that the lifeboat does not exhibit unsafe or unstable characteristics when being towed by the ship making headway at speeds up to 5 knots in calm water. Except for free-fall lifeboats, the painter securing device shall include a release device to enable the painter to be released from inside the lifeboat, with the ship making headway at speeds up to 5 knots in calm water.
- 5.7 Boats intended for launching down the side of a ship shall have skates and fenders as necessary to facilitate launching and prevent damage to the boat.
- 5.8 Unless expressly provided otherwise, every boat shall be provided with effective means of bailing or be automatically self-bailing.

*Markings*

- 6.1 Each lifeboat shall be fitted with an identity plate endorsed by the Administration, containing at least the following items:
  - 6.1.1 manufacturer's name and address;
  - 6.1.2 lifeboat model and serial number;
  - 6.1.3 month and year of manufacture;
  - 6.1.4 number of persons the lifeboat is approved to carry; and
  - 6.1.5 the approval information required under Schedule 1 paragraph 1.9.
- 6.2 The certifying organization shall provide the lifeboat with a certificate of approval which, in addition to the above items, specifies:
  - 6.2.1 number of certificate of approval;
  - 6.2.2 material of hull construction, in such detail as to ensure that compatibility problems in repair should not occur;
  - 6.2.3 total mass fully equipped and fully manned; and

- 6.2.4 statement of approval as to Parts 3, 4, 5, 6, 7, 8, 9 or 10 of Schedule 2.
- 6.3 The name and port of registry of the ship to which the boat belongs shall be marked on each side of the boat's bow in block capitals.
- 6.4 Means of identifying the ship to which the boat belongs and the number of the boat shall be marked in such a way that they are visible from above.

*Instructions and information*

- 7.1 Instructions and information required for inclusion in the training manual and in the instructions for on-board maintenance specified in Schedule 14 shall be in a suitable form. Instructions and information shall be in English, in a clear and concise form, and shall include –
  - 7.1.1 a general description of the boat and its equipment;
  - 7.1.2 the installation arrangements;
  - 7.1.3 operational instructions including use of associated survival equipment;
  - 7.1.4 survival instructions;
  - 7.1.5 emergency repair instructions;
  - 7.1.6 deployment, boarding and launching instructions;
  - 7.1.7 the method of launching from within the boat;
  - 7.1.8 the release from launching appliance;
  - 7.1.9 the on-board maintenance requirements;
  - 7.1.10 the servicing requirements;
  - 7.1.11 the use of engine and accessories; and
  - 7.1.12 the recovery of boat including stowage and securing.

*Disengaging gears*

- 8.1 Except in the case of single point suspension a boat disengaging gear shall be so arranged that all hooks are released simultaneously on the operation of the control mechanism.
- 8.2 The means of effecting release shall be placed near the coxswain's position.
- 8.3 The gear shall have two release capabilities –
  - 8.3.1 a normal release capability which will release the boat only when it is waterborne or when there is no load on the hook; and
  - 8.3.2 an on-load release capability which will release the boat with a load on the hook(s). This release shall be so arranged as to release the boat under any condition of loading from no-load with the boat waterborne to a load of 1.1 times the total mass of the boat when loaded with its full complement of persons and equipment. This release shall be adequately protected against accidental or premature use. Adequate protection shall include special mechanical protection not normally required for offload release, in addition to a danger sign. To prevent an accidental release during

recovery of the boat, the mechanical protection interlock should only engage when the release mechanism is properly and completely reset. To prevent a premature on-load release, on-load operation of the release mechanism should require a deliberate and sustained action by the operator. The release mechanism shall be so designed that crew members in the lifeboat can clearly observe when the release mechanism is properly and completely reset and ready for lifting. Clear operating instructions should be provided with a suitable worded warning notice;

- 8.3.3** where a single fall and hook system is used for launching a lifeboat or rescue boat in combination with a suitable painter, the requirements of paragraph 8.3 need not be applicable; in such an arrangement a single capability to release the lifeboat or rescue boat, only when it is fully waterborne, will be adequate.
- 8.4** The means of connection between the hook, safety device and the operating lever or release unit shall –
- 8.4.1** be arranged and led so as to ensure the efficient operation of the gear;
- 8.4.2** wherever necessary be properly cased in for the safety or efficient action of the gear or for the protection of persons from injury; and
- 8.4.3** where cased in, means shall be provided for lubricating this equipment.
- 8.5** The release control shall be clearly marked in a colour that contrasts with its surroundings, and a suitably worded instruction plate indicating the method of safe operation of the gear shall be provided.
- 8.6** Such parts of the gear as would otherwise be likely to be set fast by rust or corrosion shall be made of non-corrodible metal.
- 8.7** The mechanism shall be designed with a factor of safety of 6 based on the ultimate strength of the materials used, assuming that the mass of the lifeboat is equally distributed.

**Small Passenger Ship Regulations**  
regs 5, 6 and 7

**Other Ships Regulations**  
regs 42, 43, 44, 45, 48,  
63, 64, 65, 66 and 69

## **PART 2 - LIFEBOATS**

### **General**

1. Lifeboats shall comply with the requirements of Part 1, and in addition shall comply with the requirements of this Part.

### **Construction**

- 2.1** The vertical distance between the floor surface and the interior of the enclosure or canopy over 50 per cent of the floor area shall be –
- 2.1.1** not less than 1.3 metres for a lifeboat permitted to accommodate 9 persons or less;
- 2.1.2** not less than 1.7 metres for a lifeboat permitted to accommodate 24 persons or more; and
- 2.1.3** not less than the distance determined by linear interpolation between 1.3 metres and 1.7 metres for a lifeboat permitted to accommodate between 9 and 24 persons.
- 2.2** No lifeboat shall be deemed fit to accommodate more than 150 persons.

- 2.3 The number of persons which a lifeboat shall be permitted to accommodate shall be equal to the lesser of –
- 2.3.1 the number of persons having an average mass of 75 kilogrammes, all wearing lifejackets, that can be seated in a normal position without interfering with the means of propulsion or the operation of any of the lifeboat's equipment; or
- 2.3.2 the number of spaces that can be provided on the seating arrangements in accordance with figure 1. The shapes may be overlapped as shown, provided footrests are fitted and there is sufficient room for legs, and the vertical separation between the upper and lower seats is not less than 350 millimetres.

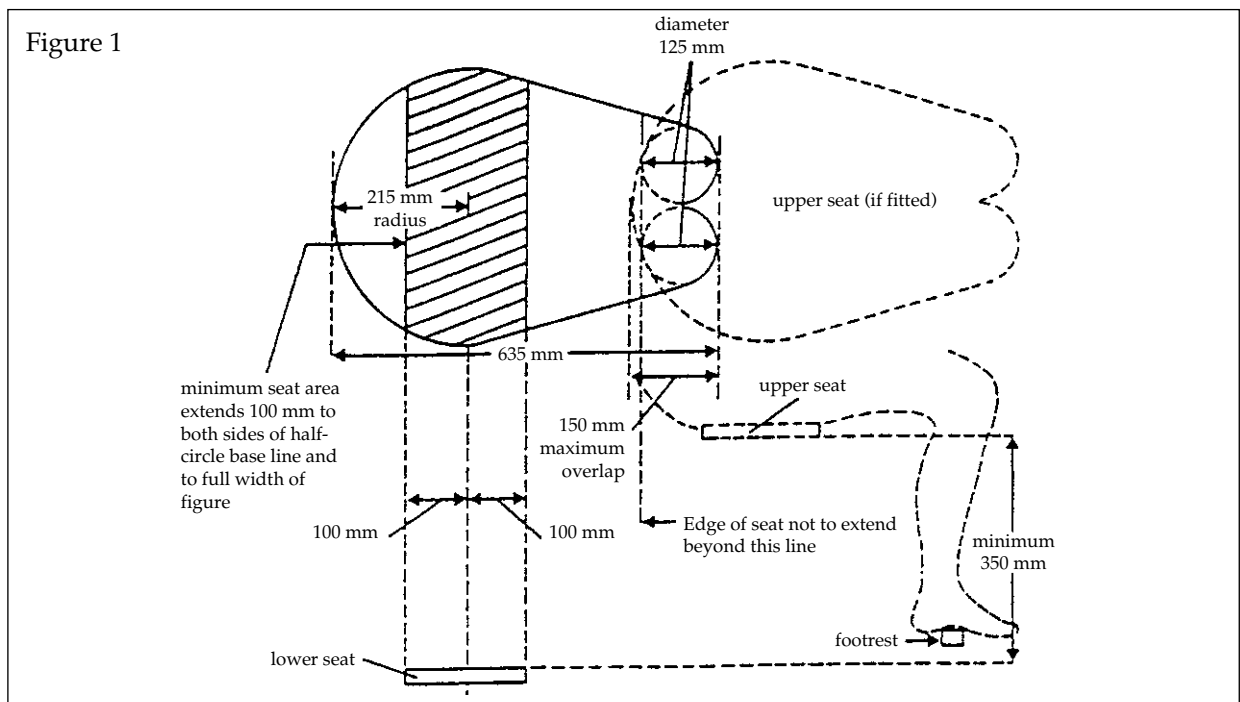

- 2.4 Every passenger ship lifeboat shall be so arranged that it can be rapidly boarded by its full complement of persons. Rapid disembarkation shall also be possible.
- 2.5 Every cargo ship lifeboat shall be so arranged that it can be boarded by its full complement of persons in not more than 3 minutes from the time the instruction to board is given. Rapid disembarkation shall also be possible.

### *Propulsion*

- 3.1 Every lifeboat engine shall be capable of operating when the lifeboat is listed 10 degrees either way or trimmed 10 degrees either way.
- 3.2 The speed of a lifeboat when proceeding ahead in calm water, when loaded with its full complement of persons and equipment and with all engine-powered auxiliary equipment in operation, shall be at least 6 knots and at least 2 knots when towing a 25-person liferaft loaded with its full complement of persons and equipment or its equivalent. Sufficient fuel, suitable for use in the temperature range expected in the area in which the ship operates, shall be provided to run the fully loaded lifeboat at 6 knots for a period of not less than 24 hours.

### *Fittings*

- 4.1 Lifeboats shall be fitted with sufficient watertight lockers or compartments to provide for the storage of the small items of equipment, water and provisions required by section 5. Means shall be provided for the storage of collected rainwater.

- 4.2 Every lifeboat which is fitted with a fixed, two-way VHF radiotelephone apparatus with an antenna which is separately mounted shall be provided with arrangements for siting and securing the antenna effectively in its operating position.
- 4.3 A manually controlled lamp complying with the requirements of section 7 shall be fitted to the top of the cover or enclosure.
- 4.4 A lamp or source of light complying with the requirements of section 7 shall be fitted inside the lifeboat; however, oil lamps shall not be permitted for this purpose.
- 4.5 Every lifeboat shall be so arranged that an adequate view forward, aft and to both sides is provided from the control and steering position for safe launching and manoeuvring.

### *Equipment*

- 5.1 All items of lifeboat equipment, whether required by this paragraph or elsewhere in this Schedule, with the exception of boat-hooks which shall be kept available for fending off purposes, shall be secured within the lifeboat by lashings, storage in lockers or compartments, storage in brackets or similar mounting arrangements or other suitable means. The equipment shall be secured in such a manner as not to interfere with any abandonment procedures. All items of lifeboat equipment shall be as small and of as little mass as possible and shall be packed in a suitable and compact form. Except as stated in paragraph 5.2, the normal equipment of every lifeboat shall consist of –
  - 5.1.1 except for free-fall liferafts, sufficient buoyant oars to make headway in calm seas; thole pins, crutches or equivalent arrangements shall be provided for each oar provided; thole pins or crutches shall be attached to the boat by lanyards or chains;
  - 5.1.2 two boat-hooks;
  - 5.1.3 a buoyant bailer and two buckets;
  - 5.1.4 a survival manual;
  - 5.1.5 an operational compass which is luminous or provided with suitable means of illumination. In a totally enclosed lifeboat the binnacle shall be permanently fitted at the steering position; in any other lifeboat, it shall be provided with suitable mounting arrangements;
  - 5.1.6 a sea-anchor;
  - 5.1.7 two efficient painters of a length equal to not less than twice the distance from the stowage position of the lifeboat to the waterline in the lightest seagoing condition or 15 metres whichever is the greater. On free-fall lifeboats both painters shall be stowed near the bow ready for use. On other lifeboats, one painter attached to the release device required by paragraph 5.6 of Part 1 shall be placed at the forward end of the lifeboat and the other shall be stored at or near the bow of the lifeboat ready for use;
  - 5.1.8 two hatchets, one at each end of the lifeboat;
  - 5.1.9 watertight receptacles complying with the requirements of Schedule 13 and containing a total of 3 litres of fresh water for each person the lifeboat is permitted to accommodate, of which 1 litre per person may be replaced by a de-salting apparatus capable of producing an equal amount of fresh water in 2 days or 2 litres per person may be replaced by a manually powered reverse osmosis desalinator capable of producing an equal amount of fresh water in 2 days;

- 5.1.10 three rustproof graduated drinking vessels, one suitably graduated in millilitres;
  - 5.1.11 food rations totalling not less than 10,000 kilojoules for each person the lifeboat is permitted to accommodate; these rations shall be kept in airtight packaging and be stowed in a watertight container;
  - 5.1.12 four rocket parachute flares;
  - 5.1.13 six hand flares;
  - 5.1.14 two buoyant smoke signals;
  - 5.1.15 one waterproof electric torch suitable for Morse signalling together with one spare set of batteries and one spare bulb in a waterproof container;
  - 5.1.16 one daylight signalling mirror with instructions for its use for signalling to ships and aircraft;
  - 5.1.17 one copy of the Department of Transport's Rescue Signal Table published by Her Majesty's Stationery Office;
  - 5.1.18 one whistle or equivalent sound signal;
  - 5.1.19 a first-aid outfit complying with the requirements of Schedule 13;
  - 5.1.20 anti-seasickness medicine sufficient for 48 hours and one seasickness bag for each person;
  - 5.1.21 a jack-knife to be kept attached to the boat by a lanyard;
  - 5.1.22 three tin openers;
  - 5.1.23 two buoyant rescue quoits, attached to not less than 30 metres of buoyant line;
  - 5.1.24 if the lifeboat is not automatically self bailing, a manual pump complying with the requirements of section 6;
  - 5.1.25 one set of fishing tackle;
  - 5.1.26 sufficient tools for minor adjustments to the engine and its accessories;
  - 5.1.27 two portable fire extinguishers suitable for extinguishing oil fires;
  - 5.1.28 a searchlight with a horizontal and vertical sector of at least 6 degrees and a measured luminous intensity of 2500 candela which can work continuously for not less than 3 hours;
  - 5.1.29 an efficient radar reflector unless a radar transponder is stowed in the lifeboat; and
  - 5.1.30 thermal protective aids sufficient for 10 per cent of the number of persons the lifeboat is permitted to accommodate or two, whichever is the greater.
- 5.2 In the case of ships engaged on voyages solely within the Limited European Area the items specified in paragraphs 5.1.11 and 5.1.25 need not be carried and, in the case of passenger ships of Classes III to VI(A), equipment specified in paragraph 5.1.5, 5.1.16, 5.1.17, 5.1.28, 5.1.29 and 5.1.30 need not be provided.

("Limited European Trading Area" means "an area bounded by a line from a point on the Norwegian coast in latitude 62° North to a point 62° North 02° West; thence to a point 58° North 10° West; thence to a point 54° North 14° West; thence to a point 51° North 14° West; thence to a point 38° 40' North 10° West; thence to Cape St Vincent; but excluding all waters which lie to the northward and eastward of a line between Kalmar on the East coast of Sweden and a point on the West coast of Oland in latitude 56° 40' North and from the southern tip of Oland to Gdnask, except between the dates of 1st May and 30th November when the remaining waters of the Baltic Sea are included.)

### *Manual pump*

- 6.1 Every lifeboat manual pump shall comply with the requirements of this section.
- 6.2 The capacity of the pump when operated at not more than 60 double strokes per minute at 1.2 metres suction head, shall be not less than –
  - 6.2.1 30 litres per minute in lifeboats of 7 metres in length or over; or
  - 6.2.2 20 litres per minute in lifeboats of less than 7 metres in length;
- 6.3 In its normal dry state (excluding internal grease or other assistance) the pump shall be self-priming when operated at a suction head of not less than 1.2 metres.
- 6.4 All parts of the pump shall be of a material unaffected by the corrosive effects of sea water.
- 6.5 The interior of the pump, including valves, shall be readily accessible for emergency cleaning and the cover for access shall be capable of being easily removed without the use of a spanner or other special tool.
- 6.6 The pump branches shall be suitable for use with rubber hose connections of at least 30 millimetres bore. The metal part of the operating handle shall be suitably sheathed by material other than wood to ensure that the hands of the operator are protected when the pump is used in extreme cold. The spindle gland shall be of the spring loaded seal ring type.

### *Internal and external lights*

#### *General*

- 7.1.1 Internal and external lights provided in accordance with paragraph 4.3. and 4.4 shall have a manually operated switch.
- 7.1.2 Each light shall be connected independently to its own power source unless it is operated from the lifeboat's battery system.

#### *Construction*

- 7.2.1 Each complete light unit shall be constructed with proper workmanship and materials.
- 7.2.2 It shall be capable of withstanding the drop test for a lifeboat.
- 7.2.3 It shall be capable of withstanding a drop of 2 metres onto a rigidly mounted steel plate or concrete surface.
- 7.2.4 It shall be rot proof, corrosion resistant and not unduly affected by sea-water, oil or fungal growth.

- 7.2.5 It shall not deteriorate due to damp or humidity when stowed in or on a lifeboat.
- 7.2.6 Its power source shall be proofed against leakage of any chemicals which could damage or cause deterioration of the lifeboat.
- 7.2.7 Its connection between light and power shall be suitably protected.
- 7.2.8 Its lamp, lamp holder and lens shall be so constructed as to prevent the ingress of water.
- 7.2.9 If an external light is a flashing light, it shall not be fitted with a lens or curved reflector to concentrate the beam.

*Performance*

- 7.3.1 Each light shall have an operational endurance of not less than 12 hours.
- 7.3.2 It shall not be damaged in stowage in the air temperature range  $-30^{\circ}\text{C}$  to  $+65^{\circ}\text{C}$ .
- 7.3.3 It shall operate in a satisfactory manner in a seawater temperature range of  $-1^{\circ}\text{C}$  to  $+30^{\circ}\text{C}$ .
- 7.3.4 Each internal light shall be of sufficient luminous intensity to enable survival and equipment instructions to be read.
- 7.3.5 Each external light shall be white and be capable of operating continuously with a luminous intensity of not less than 4.3 candela.
- 7.3.6 Each external light shall be visible through 360 degrees in a horizontal direction and in all directions of the upper hemisphere.
- 7.3.7 If the external light is a flashing light it shall flash at a rate of not less than 50 flashes or more than 70 flashes per minute for the 12 hours operating period with an equivalent effective luminous intensity as required by 7.3.5 above.

*Markings*

- 7.4.1 The power source, if independent of the lifeboat's battery system, shall be marked externally with –
  - 7.4.1.1 the manufacturer's name or trade mark;
  - 7.4.1.2 the type and batch number; and
  - 7.4.1.3 the date of manufacture and expiry.
- 7.4.2 If the power source is a chemical pressurised cell it shall be clearly marked with a suitable warning notice.

Other Ships Regulations  
regs 42, 43, 44, 63, 64 and 65

**PART 3 – PARTIALLY ENCLOSED LIFEBOATS**

*General*

- 1.1 Partially enclosed lifeboats shall comply with the requirements of Part 1 and 2 and in addition shall comply with the requirements of this Part.

- 1.2 Every partially enclosed lifeboat shall be provided with effective means of bailing or be automatically self-bailing.

### *Enclosure*

- 2.1 Permanently attached rigid covers shall be provided extending over not less than 20 per cent of the length of the lifeboat from the stem and not less than 20 per cent of the length of the lifeboat from the aftermost part of the lifeboat.
- 2.2 The rigid covers shall form two shelters. The interior height of the shelters shall be sufficient to permit persons easy access to their seats in the bow and stern of the lifeboat.
- 2.3 The rigid covers shall be so arranged that they include windows or translucent panels to admit sufficient daylight to the inside of the lifeboat with the openings or canopies closed so as to make artificial light unnecessary.
- 2.4 The rigid covers shall have railings to provide a secure handhold for persons moving about the exterior of the lifeboat.
- 2.5 Open parts of the lifeboat shall be fitted with a permanently attached foldable canopy so arranged that –
  - 2.5.1 it can be easily erected by not more than 2 persons; and
  - 2.5.2 it is insulated to protect the occupants against cold by means of not less than two layers of material separated by an air gap or other equally efficient means; means shall be provided to prevent accumulation of water in the air gap.
- 2.6 The enclosure formed by the rigid covers and canopy shall be so arranged –
  - 2.6.1 as to allow launching and recovery operations to be performed without any occupant having to leave the enclosure;
  - 2.6.2 that it has entrances at both ends and on each side, provided with efficient adjustable closing arrangements which can be easily and quickly opened and closed from inside or outside so as to permit ventilation but exclude seawater, wind and cold. Means shall be provided for holding the entrances securely in the open and in the closed position;
  - 2.6.3 that with the canopy erected and all entrances closed sufficient air is admitted for the occupants at all times;
  - 2.6.4 that it has means for collecting rainwater;
  - 2.6.5 that the exterior of the rigid covers and canopy and the interior of that part of the lifeboat covered by the canopy is of a highly visible colour. The interior of the shelters shall be of a colour which does not cause discomfort to the occupants; and
  - 2.6.6 that it is possible to row the lifeboat.

### *Communications*

- 3.1 Any radiotelegraph installation or any fixed two-way VHF radiotelephone set required by these Regulations shall be installed in a cabin large enough to accommodate both the equipment and the person using it; except that no separate cabin is required if the construction of the lifeboat provides a sheltered space.

## PART 4 – TOTALLY ENCLOSED LIFEBOATS

### *General*

1. Totally enclosed lifeboats shall comply with the requirements of Parts 1 and 2 of this Schedule and in addition shall comply with the requirements of this Part.

### *Enclosure*

- 2.1 Every totally enclosed lifeboat shall be provided with a rigid watertight enclosure which completely encloses the lifeboat.
- 2.2 The enclosure shall be so arranged that –
  - 2.2.1 it provides shelter for the occupants;
  - 2.2.2 access to the lifeboat is provided by hatches which can be closed to make the lifeboat watertight;
  - 2.2.3 except for free-fall lifeboats, hatches are positioned so as to allow launching and recovery operations to be performed without any occupant having to leave the enclosure;
  - 2.2.4 access hatches are capable of being opened and closed from both inside and outside and are equipped with means to hold them securely in open positions;
  - 2.2.5 except for free-fall lifeboats, it is possible to row the lifeboat;
  - 2.2.6 it is capable, when the lifeboat is in the capsized position with the hatches closed and without significant leakage, of supporting the entire mass of the lifeboat, including all equipment, machinery and its full complement of persons;
  - 2.2.7 it includes windows or translucent panels on both sides which admit sufficient daylight to the inside of the lifeboat with the hatches closed to make artificial light unnecessary;
  - 2.2.8 its exterior is of a highly visible colour and its interior of a colour which does not cause discomfort to the occupants;
  - 2.2.9 handrails provide a secure handhold for persons moving about the exterior of the lifeboat and aid embarkation and disembarkation;
  - 2.2.10 persons have access to their seats from an entrance without having to climb over thwarts or other obstructions; and
  - 2.2.11 the occupants are protected from the effects of dangerous sub-atmospheric pressures which might be created by the lifeboat's engine, during operation of the engine with entrances closed, the atmospheric pressure inside the lifeboat shall never be above the outside atmospheric pressure or fall below it by more than 20 millibar.

### *Capsizing and re-righting*

- 3.1 Except in free-fall lifeboats, a four-point safety belt and head protection shall be fitted at each indicated seating position. The safety belt shall be designed to hold a person of a mass of 100 kilogrammes securely in place when the lifeboat is in a capsized position. Each set of safety

belts for a seat shall be of a colour which contrasts with the belts for seats immediately adjacent. Free-fall lifeboats shall be fitted with a safety harness at each seat in contrasting colour designed to hold a person with a mass of 100 kilogrammes securely in place during a free-fall launch as well as with the lifeboat in capsized position.

- 3.2 The stability of the lifeboat shall be such that it is inherently or automatically self-righting when loaded with its full or partial complement of persons and equipment and all entrances and openings are closed watertight and the persons are secured with safety belts.
- 3.3 The lifeboat shall be capable of supporting its full complement of persons and equipment when the lifeboat is in the damaged condition prescribed in paragraph 3.1 of Part 1 and its stability shall be such that in the event of capsizing, it will automatically attain a position that will provide an above-water escape for its occupants. When the lifeboat is in the stable flooded condition, the water level inside the lifeboat, measured along the seatback, shall not be more than 500 millimetres above the seat pan at any occupant seating position.
- 3.4 The design of all engine exhaust pipes, air ducts and other openings shall be such that water is excluded from the engine when the lifeboat capsizes and re-rights.

### *Propulsion*

- 4.1 The engine and transmission shall be controlled from the helmsman's position.
- 4.2 The engine installation shall be capable of running in any position during capsize and continue to run after the lifeboat returns to the upright or shall automatically stop on capsizing and be easily restarted after the lifeboat returns to the upright. The design of the fuel and lubricating systems shall prevent the loss of fuel and the loss of more than 250 millilitres of lubricating oil from the engine during capsize.
- 4.3 Air-cooled engines shall have a duct system to take in cooling air from, and exhaust it to, the outside of the lifeboat. Manually operated dampers shall be provided to enable cooling air to be taken in from, and exhausted to, the interior of the lifeboat.

### *Construction and fendering*

5. Notwithstanding the requirements of paragraph 3.6 of Part 1, a totally enclosed lifeboat except a free-fall lifeboat shall be so constructed and fendered as to ensure that the lifeboat renders protection to its occupants against harmful accelerations when, loaded with its full complement of persons and equipment, it impacts against the ship's side with a velocity of not less than 3.5 metres per second.

**Other Ships Regulations**  
regs 45 and 66

## **PART 5 – LIFEBOATS WITH A SELF-CONTAINED AIR SUPPORT SYSTEM**

### *General*

- 1.1 Lifeboats with a self-contained air support system shall comply with the requirements of Parts 1, 2 and 4 and if a free-fall lifeboat, comply with Part 9 and in addition shall comply with the requirements of this Part.
- 1.2 Every lifeboat with a self-contained air supply system shall be so arranged that, when proceeding with all entrances and openings closed, the air in the lifeboat remains safe and breathable and the engine runs normally for a period of not less than 10 minutes. During this period the atmospheric pressure inside the lifeboat shall never fall below the outside atmospheric pressure nor shall it exceed it by more than 20 millibar. The system shall have visual indicators to indicate the pressure of the air supply at all times.

## PART 6 – FIRE-PROTECTED LIFEBOATS

### *General*

- 1.1 Fire-protected lifeboats shall comply with the requirements of Parts 1, 2, 4 and 5 and if a free-fall lifeboat, comply with Part 9 and in addition shall comply with the requirements of this Part.
- 1.2 Every fire-protected lifeboat when waterborne shall be capable of protecting the number of persons it is permitted to accommodate when subjected to a continuous oil fire that envelops the lifeboat for a period of not less than 8 minutes.

### *Water spray system*

- 2.1 A lifeboat which has a water spray fire-protection system shall comply with the following –
  - 2.1.1 water for the system shall be drawn from the sea by a self-priming motor pump. It shall be possible to turn on and turn off the flow of water over the exterior of the lifeboat;
  - 2.1.2 the seawater intake shall be so arranged as to prevent the intake of flammable liquids from the sea surface;
  - 2.1.3 the system shall be arranged for flushing with fresh water and allowing complete drainage; and
  - 2.1.4 when an external light is fitted to a fire-protected lifeboat it shall be protected by the water-spray system.

Small Passenger Ship Regulations  
regs 5 and 6

Other Ships Regulations  
regs 42, 43, 44, 45, 47, 48  
63, 64, 65, 66, 68 and 69

## PART 7 – RIGID RESCUE BOATS

### *General*

- 1.1 Rigid rescue boats shall comply with the requirements of Part 1 and in addition shall comply with the requirements of this Part.
- 1.2 A lifeboat may be accepted as a rigid rescue lifeboat provided it also complies with the requirements of this Part and its stowage, launching and recovery arrangements meet all the requirements for a rescue boat.

### *Construction*

- 2.1 The number of persons which a boat shall be permitted to accommodate shall be equal to the lesser of –
  - 2.1.1 the number of persons having an average mass of 75 kilogrammes, all wearing lifejackets, that can be seated in a normal position plus one person lying down on a stretcher without interfering with the means of propulsion or the operation of any of the boat's equipment; or

- 2.1.2 the number of spaces that can be provided on the seating arrangements in accordance with figure 2, plus one person lying down on a stretcher, seating except for the helmsman may be provided on the floor provided that the seating space analysis uses shapes similar to figure 2 but altered to an overall length of 1190 millimetres to provide for extended legs, no part of a seating space shall be on the gunwale, transom or on inflated buoyancy at the side of a boat.

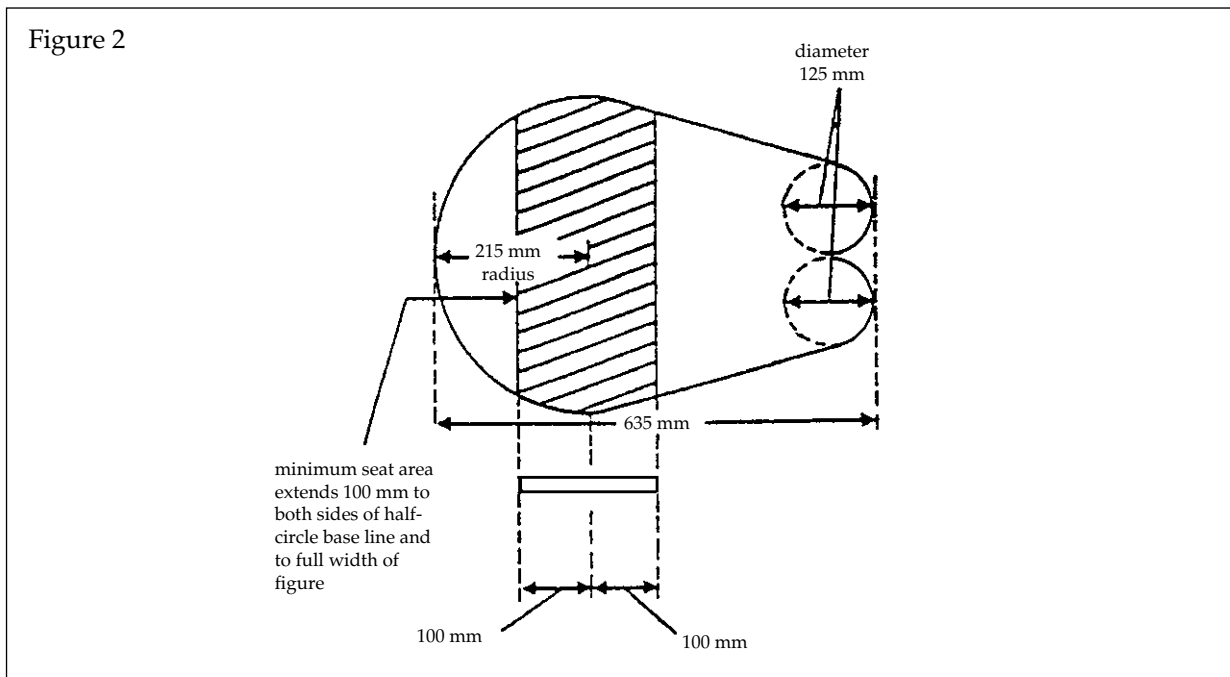

- 2.2 Boats shall be –
- 2.2.1 not less than 3.8 metres and not more than 8.5 metres in length; and
- 2.2.2 capable of carrying at least 5 seated persons and a person lying down.
- 2.3 Unless the boat has adequate sheer it shall be provided with a bow cover extending for not less than 15 per cent of its length.
- 2.4 Boats shall be capable of manoeuvring at speeds of at least 6 knots and maintaining a speed of 6 knots for a period of at least 4 hours.
- 2.5 Boats shall have sufficient mobility and manoeuvrability in a seaway to enable persons to be retrieved from the water, marshal liferafts and tow the largest liferaft carried on the ship when loaded with its full complement of persons and equipment or its equivalent at a speed of at least 2 knots.
- 2.6 Boats shall be fitted with an inboard or outboard engine complying with the relevant parts of section 3.
- 2.7 Arrangements for towing shall be permanently fitted and shall be sufficiently strong to marshal or tow liferafts as required by paragraph 2.5.
- 2.8 Boats shall be fitted with weathertight stowage for small items of equipment.
- 2.9 Boats shall be fitted with a protective stowage cover and shall be kept covered at all times when the boat is not in use. The cover shall be arranged for quick removal in an emergency.

- 2.10 Unless expressly provided otherwise, every rescue boat shall be provided with effective means of bailing or be automatically self bailing.
- 2.11 Buoyant material for rescue boats may be installed external to the hull, provided it is adequately protected against damage and is capable of withstanding exposure conditions described in Part 8 paragraph 2.6.

### *Propulsion*

- 3.1 Where a boat is powered by an inboard engine it shall be of the compression ignition type complying with the requirements of paragraph 4.1 of Part 1.
- 3.2 Outboard engines using petrol or diesel oil as fuel shall be fitted with approved fuel systems. Petrol storage tanks shall be specially protected against fire and explosion. A starting system, which shall not be impeded by the engine casing, thwarts or other obstructions and which may include starting aids, shall be fitted and be capable of starting the engine –
- 3.2.1 at the ambient temperature and, within 2 minutes of commencing the starting procedure, at an ambient temperature of  $-15^{\circ}\text{C}$ , by manual means; or
- 3.2.2 at the ambient temperature by manual means and, within 2 minutes of commencing the starting procedure, by a powered starting system at an ambient temperature of  $-15^{\circ}\text{C}$ : except that if the ship on which the boat and its engine are carried, is constantly engaged on voyages where a different temperature is appropriate, that temperature may be substituted for  $-15^{\circ}\text{C}$ .

### *Equipment*

- 4.1 All items of rescue boat equipment, with the exception of the boat hook which shall be kept available for fending off purposes, shall be secured within the boat by lashings, storage in lockers or compartments, storage in brackets or similar mounting arrangements, or other suitable means. The equipment shall be secured in such a manner as not to interfere with any launching or recovery procedures. All items of boat equipment shall be as small and of little mass as possible and shall be packed in suitable and compact form.
- 4.2 The equipment of every boat shall consist of –
- 4.2.1 sufficient buoyant oars or paddles to make headway in calm seas; thole pins, crutches or equivalent arrangements shall be provided for each oar; thole pins or crutches shall be attached to the boat by lanyards or chains;
- 4.2.2 a buoyant bailer;
- 4.2.3 a binnacle containing an efficient compass which is luminous or provided with suitable means of illumination;
- 4.2.4 a sea-anchor;
- 4.2.5 a painter of sufficient length and strength, attached to the release device complying with the requirements of paragraph 5.6 of Part 1 and placed at the forward end of the boat;
- 4.2.6 one buoyant line, not less than 50 metres in length, of sufficient strength to tow a liferaft as required by paragraph 2.5;
- 4.2.7 one waterproof electric torch suitable for Morse signalling, together with one spare set of batteries and one spare bulb in a waterproof container;

- 4.2.8 one whistle or equivalent sound signal;
- 4.2.9 a first-aid outfit complying with the requirements of Schedule 13;
- 4.2.10 two buoyant rescue quoits, attached to not less than 30 metres of buoyant line with a breaking strain of at least 1.0 kilonewton;
- 4.2.11 a searchlight with a horizontal and vertical sector of at least 6 degrees and a measured luminous intensity of 2500 candela which can work continuously for not less than 3 hours;
- 4.2.12 an efficient radar reflector;
- 4.2.13 thermal protective aids sufficient for 10 per cent of the number of persons the rescue boat is permitted to accommodate, or two, whichever is greater;
- 4.2.14 a boat hook;
- 4.2.15 a bucket;
- 4.2.16 a knife or hatchet;
- 4.2.17 a portable fire extinguisher suitable for extinguishing oil fires; and
- 4.2.18 a manually controlled lamp complying with the requirement of Part 2 Section 6.

In passenger ships of Classes III to VI(A) the equipment specified in paragraphs 4.2.3, 4.2.11, 4.2.12 and 4.2.13 need not be provided.

#### *Access into boats*

- 5.1 Every passenger ship rigid rescue boat shall be so arranged that it can be rapidly boarded by its rescue complement of persons. Rapid disembarkation shall also be possible.
- 5.2 Every cargo ship rigid rescue boat shall be so arranged that it can be boarded by its rescue complement of persons in not more than 3 minutes from the time the instruction is given. Rapid disembarkation shall also be possible.

**Small Passenger Ship Regulations**  
regs 5 and 6

**Other Ships Regulations**  
regs 42, 43, 44, 45, 47, 48  
63, 64, 65, 66, 68 and 69

## **PART 8 – RIGID INFLATED RESCUE BOATS**

### *General*

- 1.1 A rigid inflated rescue boat is a composite craft combining a rigid lower hull and inflated tubes fitted at the edge of the lower hull forming a watertight boundary.
- 1.2 Rigid inflated rescue boats shall comply with all the requirements of Part 1 with the exception of paragraph 3.11, and with Part 7 with the exception of paragraph 1.2, and in addition with the requirements of this Part.

### *Construction*

- 2.1 The buoyancy of the boat shall be a combination of inherent and inflated buoyancy.
- 2.2 The inflated buoyancy tube shall be a single tube sub-divided into at least five separate compartments of approximately equal volume.

- 2.3 Boats shall have adequate inherent buoyancy or inherently buoyant material together with the inflatable compartments on one side (excluding the forward compartment) when inflated, sufficient to float the boat with all its equipment on board when flooded and open to the sea.
- 2.4 Additional inherent buoyancy equal to 140 newtons of buoyancy force per person shall be provided for the number of persons the boat is permitted to accommodate. This additional buoyancy may be installed externally to the rigid hull of the boat provided it is adequately protected against damage and is capable of withstanding exposure conditions described in paragraph 2.6.
- 2.5 Inherently buoyant material shall not be adversely affected by seawater, oil or oil products.
- 2.6 Boats shall be so constructed as to be capable of withstanding exposure –
  - 2.6.1 when stowed on an open deck on a ship at sea;
  - 2.6.2 for 30 days afloat in all sea conditions.
- 2.7 The buoyancy tubes forming the boundary of the boat shall on inflation provide a volume of not less than 0.17 cubic metres for each person the boat is permitted to accommodate and the diameter of the main buoyancy chamber must be at least 0.43 metres.
- 2.8 Each buoyancy compartment shall be fitted with a non-return valve for manual inflation and means for deflation. A safety relief valve shall also be fitted to each buoyancy compartment.
- 2.9 The inflated buoyancy tubes shall be maintained at all times in a fully inflated condition.

#### *Markings*

- 3. If any of the markings required by section 6 of Part 1 are marked on the buoyancy tubes, the materials used to mark them shall be of a type which is compatible with the boat's coated fabric and approved by the boat manufacturer.

#### *Equipment*

- 4. In addition to the equipment required by section 4.2 of Part 7 the following items are required –
  - 4.1. an efficient manually operated bellows or pump; and
  - 4.2. a repair kit in a suitable container for repairing punctures to the coated fabric of the buoyancy tubes.

**Other Ships Regulations**  
regs 65 and 66

### **PART 9 – FREE-FALL LIFEBOATS**

#### *General*

- 1. Free-fall lifeboats shall comply with the requirements of Part 4 and in addition shall comply with the requirements of this Part.

#### *Carrying capacity of a free-fall lifeboat*

- 2. The carrying capacity of a free-fall lifeboat is the number of persons that can be provided with a seat without interfering with the means of propulsion or the operation of any of the lifeboat's equipment.

The width of the seat shall be at least 430 millimetres. Free clearance in front of the backrest shall be at least 635 millimetres. The backrest shall extend at least 1,000 millimetres above the seatpan.

### *Performance requirements*

- 3.1 Each free-fall lifeboat shall make positive headway immediately after water entry and shall not come into contact with the ship after a free-fall launching against a trim of up to 10 degrees and a list of up to 20 degrees either way from the certification height when fully equipped and loaded with:
  - 3.1.1 its full complement of persons;
  - 3.1.2 occupants so as to cause the centre of gravity to be in the most forward position;
  - 3.1.3 occupants so as to cause the centre of gravity to be in the most aft position, and
  - 3.1.4 its operating crew only.
- 3.2 For oil tankers, chemical tankers and gas carriers with a final angle of heel greater than 20 degrees calculated in accordance with the requirements of Part 1, Schedule 6, paragraph 1.2, as applicable, a lifeboat shall be capable of being free-fall launched at the final angle of heel and on the base of the final waterline of that calculation.
- 3.3 The required free-fall height shall never exceed the free-fall certification height.

### *Construction*

4. Each free-fall lifeboat shall be of sufficient strength to withstand, when loaded with its full complement of persons and equipment, a free-fall launch from a height of at least 1.3 times the free-fall certification height.

### *Protection against harmful acceleration*

- 5.1 Each free-fall lifeboat shall be so constructed as to ensure that the lifeboat is capable of rendering protection resulting from being launched from the height for which it is to be certified in calm water under unfavourable conditions of trim up to 10 degrees and list of up to 20 degrees either way when it is fully equipped and loaded with:
  - 5.1.1 its full complement of persons;
  - 5.1.2 one half of its full complement of persons distributed so as to cause the centre of gravity to be in the most forward position;
  - 5.1.3 one half of its full complement of persons distributed so as to cause the centre of gravity to be in the most aft position; and
  - 5.1.4 the operating crew only.

### *Lifeboat fittings*

- 6.1 Each free-fall lifeboat shall be fitted with a release system which shall:
  - 6.1.1 have two independent activation systems for the release mechanisms which may only be operated from inside the lifeboat and be marked in a colour that contrasts with its surroundings;
  - 6.1.2 be so arranged as to release the boat under any condition of loading from no load up to at least 200 per cent of the normal load caused by the fully equipped lifeboat when loaded with the number of persons for which it is to be approved;

- 6.1.3 be adequately protected against accidental or premature use;
- 6.1.4 be designed to test the release system without launching the lifeboat; and
- 6.1.5 be designed with a factor of safety of 6 based on the ultimate strength of the materials used.

*Certificate of approval*

- 7.1 In addition to the requirements of this Schedule, Part 1, paragraph 6.1 the certificate of approval for a free-fall lifeboat shall also state:
  - 7.1.1 free-fall certification height;
  - 7.1.2 required launching ramp length; and
  - 7.1.3 launching ramp angle for the free-fall certification height.

**Other Ships Regulations**  
regs 7, 8, 9, 63 and 64

**PART 10 – FAST RESCUE BOATS, RIGID AND RIGID INFLATED**

**General**

- 1.1 Except as provided by this Part all fast rescue boats shall comply with the applicable requirements of:
  - 1.1.1 rigid rescue boats – Part 7; and
  - 1.1.2 rigid inflated rescue boats – Part 8 and with the following requirements.
- 1.2 Fast rescue boats shall be not less than 6 metres in length and not more than 8 metres.
- 1.3 Fast rescue boats shall be capable of manoeuvring, for at least 4 hours, at a speed of at least 20 knots in calm water with a suitably qualified crew of 3 persons and at least 8 knots with a full complement of persons and equipment.
- 1.4 Fast rescue boats shall be self-righting or capable of being readily righted by their crew.
- 1.5 Fast rescue boats shall be self-bailing or be capable of being rapidly cleared of water.
- 1.6 Fast rescue boats shall be steered by a wheel at a helmsman's position remote from the tiller. An emergency steering system providing direct control of the rudder, water jet, or outboard motor shall also be provided.
- 1.7 Engines in fast rescue boats shall stop automatically or be stopped by the helmsman's emergency release switch should the rescue boat capsize. When the rescue boat has righted, each engine or motor should be capable of being restarted, provided the helmsman's emergency release, if fitted, has been reset. The design of the fuel and lubricating systems shall prevent the loss of more than 250 ml of fuel or lubricating oil from the propulsion system should the rescue boat capsize.
- 1.8 Fast rescue boats shall, if possible, be equipped with an easily operated fixed single-point suspension arrangement or equivalent.

### SCHEDULE 3

## INFLATED RESCUE BOATS AND INFLATED BOATS

### PART 1 – GENERAL

#### *General*

- 1.1 Inflated rescue boats and inflated boats are craft combining a flexible lower hull and inflated tubes fitted at the edge of the lower hull, together with forming a watertight boundary and which rely solely on the buoyancy of the inflated tubes as the inherent buoyancy of the craft.
- 1.2 Inflated rescue boats and inflated boats shall comply with the requirements of Schedule 1 and of this Part.

#### *Construction*

- 2.1 Boats shall be properly constructed and be of such form and proportion that they have ample stability in a seaway and sufficient freeboard when loaded with their full complement of persons and equipment. Boats shall be capable of maintaining positive stability in an upright position in calm water when loaded with their full complement of persons and equipment and fully swamped.
- 2.2 Each boat shall be of sufficient strength to withstand, when loaded with its full complement of persons and equipment and with, where applicable, skates or fenders in position, a lateral impact against the ship's side at an impact velocity of at least 3.5 metres per second and also a drop into the water from a height of at least 3 metres.
- 2.3 The number of persons which a boat shall be permitted to accommodate shall be equal to the lesser of –
- 2.3.1 The number of persons having an average mass of 75 kilogrammes, all wearing lifejackets, that can be seated inboard of the buoyancy tubes in a normal position plus one person lying down without interfering with the means of propulsion or the operation of any of the boat's equipment; or
- 2.3.2 the number of spaces that can be provided on the seating arrangements in accordance with figure 2 in Part 7 of Schedule 2 plus one person lying down on a stretcher. Seating, except for the helmsman, may be provided on the floor provided that the seating space analysis uses shapes similar to figure 2 in Part 7 but altered to an overall length of 1190 millimetres to provide for extended legs, no part of a seating space shall be on the gunwale, transom or on inflated buoyancy at the sides of the boat.
- 2.4 Each seating position shall be clearly indicated in the boat.
- 2.5 Boats shall have a boarding ladder that can be used on either side of the boat to enable persons in the water to board the boat. The lowest step of the ladder shall be weighted and float at a level not less than 0.4 metres below the boat's light waterline.
- 2.6 The boat shall be so arranged that helpless people can be brought on board either from the sea or on stretchers.

- 2.7** Surfaces on which persons might walk shall have a non-skid finish.
- 2.8** Boats, when loaded with 50 per cent of the number of persons they are permitted to accommodate seated in their normal positions to one side of the centreline, shall have a freeboard measured from the waterline to the lowest opening through which the boat may become flooded, of at least 1.5 per cent of the boat's length or 100 millimetres, whichever is the greater.
- 2.9** Boats without adequate sheer, shall be provided with a bow cover of highly visible colour extending for not less than 15 per cent of their length and angled upwards to deflect water and spray.
- 2.10** Boats shall have sufficient mobility and manoeuvrability in a seaway to enable persons to be retrieved from the water, marshal liferafts and tow the largest liferaft carried on the ship, when loaded with their full complement of persons and equipment, or its equivalent, at a speed of at least 2 knots.
- 2.11** Arrangements for towing shall be permanently fitted in boats and shall be sufficiently strong to marshal or tow liferafts as required by paragraph 2.10.
- 2.12** Boats shall be fitted with weathertight stowage for small items of equipment.
- 2.13** A boat shall be so constructed as to be capable of withstanding exposure –
- 2.13.1** when stowed on an open deck on a ship at sea; and
- 2.13.2** for 30 days afloat in all sea conditions.
- 2.14** Buoyancy shall be provided by either a single tube subdivided into at least five separate compartments of approximately equal volume or two separate tubes neither exceeding 60 per cent of the total volume. Buoyancy tubes shall be so arranged that, in the event of any one of the compartments being damaged, the intact compartments shall be able to support, with positive freeboard over the boat's entire periphery, the number of persons which the boat is permitted to accommodate, each having a mass of 75 kilogrammes, and seated in their normal positions under the following conditions:
- 2.14.1** with the forward buoyancy compartment deflated;
- 2.14.2** with the entire buoyancy on one side of the rescue boat deflated; and
- 2.14.3** with the entire buoyancy on one side and the bow compartment deflated.
- 2.15** Buoyancy tubes forming the boundary of the boat shall on inflation provide a volume of not less than 0.17 cubic metres for each person the boat is permitted to accommodate and the diameter of the main buoyancy chamber must be at least 0.43 metres.
- 2.16** Each buoyancy compartment shall be fitted with a non-return valve for manual inflation and means for deflation. A safety relief valve shall also be fitted to each buoyancy compartment which in the case of an inflated boat shall be designed to operate at a pressure not exceeding 125 per cent of the designed working pressure of the buoyancy chamber.
- 2.17** When inverted in the water a boat shall be capable of being righted by not more than 2 persons.
- 2.18** Rubbing strips shall be provided underneath the bottom and on vulnerable places on the outside of the boat.

- 2.19 Where a transom is fitted it shall not be inset by more than 20 per cent of the overall length of the boat.
- 2.20 Suitable patches shall be provided for securing painters forward and aft and becketed lifelines inside and outside the boat.
- 2.21 Boats shall be maintained at all times in a fully inflated condition.
- 2.22 Boats shall be fitted with a protective stowage cover and shall be kept covered at all times when not in use. The cover shall be arranged for quick removal in an emergency.

### *Propulsion*

- 3.1 Unless the propeller is so arranged so as to avoid its rotation constituting a danger to people in the water adjacent to it the drive arrangement between the prime mover and the propeller shall be such that the propeller can be brought to rest without stopping the prime mover. Provision shall be made for ahead and astern propulsion of the craft.
- 3.2 The exhaust pipe shall be so arranged as to prevent water from entering the engine in normal operation.
- 3.3 Boats shall be designed with due regard to the safety of persons in the water and to the possibility of damage to the propulsion system by floating debris.
- 3.4 The boat engine and accessories shall be designed to limit electromagnetic emissions so that engine operation does not interfere with the operation of radio life-saving appliances used in the boat.
- 3.5 Water-resistant instructions for starting and operating the engine shall be provided and mounted in a conspicuous place near the engine starting controls.

### *Fittings*

- 4.1 Boats shall be provided with at least one drain valve fitted near the lowest point in the hull, which shall automatically open to drain water from the hull when the boat is not waterborne and shall automatically close to prevent entry of water when the boat is waterborne. Each drain valve shall be provided with a cap or plug to close the valve, which shall be readily attached to the boat by a lanyard, chain, or other suitable means. Drain valves shall be readily accessible and capable of being closed from inside the boat and their position shall be clearly indicated.
- 4.2 Boats which are not self-righting when capsized shall have suitable handholds on the underside of the hull to enable persons to cling to the boat. The handholds shall be fastened to the boat in such a way that, when subjected to an impact sufficient to cause them to break away from the boat, they break away without damaging the boat.
- 4.3 Every boat to be launched by a fall or falls shall be fitted with a release mechanism complying with section 8, Part 1 of Schedule 2 except those which are launched by a single suspension which may have an approved release mechanism which is operable when the boat is waterborne.
- 4.4 Unless expressly provided otherwise, every boat shall be provided with effective means of bailing or be automatically self-bailing.

## *Markings*

- 5.1 The dimensions of the boat, the number of persons which it is permitted to accommodate, the maker's serial number, name or trade mark and the date of manufacture shall be marked on the boat in clear permanent characters.
- 5.2 The name and port of registry of the ship to which the boat belongs shall be marked on each side of the boat's bow in block capitals.
- 5.3 Means of identifying the ship to which the boat belongs and the number of the boat shall be marked in such a way that they are visible from above.
- 5.4 All materials used to mark a boat shall be of a type which is compatible with the boat's coated fabric and approved by the boat manufacturer.

## *Equipment*

- 6.1 All items of boat equipment, with the exception of the boat-hook which shall be kept available for fending off purposes, shall be secured within the boat by lashings, storage lockers or compartments, storage in brackets or similar mounting arrangements, or other suitable means. The equipment shall be secured in such a manner as not to interfere with any launching or recovery procedures. All items of boat equipment shall be as small and of as little mass as possible and shall be packed in suitable and compact form.
- 6.2 The equipment of every boat shall consist of –
  - 6.2.1 a buoyant bailer;
  - 6.2.2 a sea-anchor;
  - 6.2.3 one buoyant line, not less than 50 metres in length, of sufficient strength to tow a liferaft as required by paragraph 2.10;
  - 6.2.4 one waterproof electric torch suitable for Morse signalling, together with one spare set of batteries and one spare bulb in a waterproof container;
  - 6.2.5 one whistle or equivalent sound signal;
  - 6.2.6 a first-aid outfit complying with the requirements of Schedule 13;
  - 6.2.7 two buoyant rescue quoits, attached to not less than 30 metres of buoyant line with a breaking strain of at least 1.0 kilonewtons;
  - 6.2.8 a buoyant safety knife;
  - 6.2.9 two sponges;
  - 6.2.10 an efficient manually operated bellows or pump;
  - 6.2.11 a puncture repair kit in a suitable container;
  - 6.2.12 a safety boat hook;
  - 6.2.13 a portable fire extinguisher suitable for extinguishing oil fires; and
  - 6.2.14 a manually controlled lamp complying with the requirements of Part 2, Section 7.

## *Instructions and Information*

- 7.1 Instructions and information required for inclusion in the training manual and in the instructions for on-board maintenance specified in Schedule 14 shall be in a form suitable for inclusion in such training manual and instructions for on-board maintenance. Instructions and information shall be in English in a clear and concise form and shall include, as appropriate, the following –
- 7.1.1 a general description of the boat and its equipment;
  - 7.1.2 the installation arrangements;
  - 7.1.3 operational instructions including use of associated survival equipment;
  - 7.1.4 survival instructions;
  - 7.1.5 emergency repair instructions;
  - 7.1.6 deployment, boarding and launching instructions;
  - 7.1.7 the method of launching from within the boat;
  - 7.1.8 the release from launching appliance;
  - 7.1.9 on-board maintenance requirements;
  - 7.1.10 servicing requirements;
  - 7.1.11 the use of engine and accessories; and
  - 7.1.12 the recovery of boat including stowage and securing.

Small Passenger Ship Regulations  
regs 5 and 6

Other Ships Regulations  
regs 42, 43, 44, 45, 47, 48  
63, 64, 65, 66, 68 and 69

## **PART 2 – INFLATED RESCUE BOAT**

### *General*

1. Inflated rescue boats shall comply with the requirements of Part 1 and in addition with the requirements of this Part.

### *Construction*

- 2.1 Boats shall be of sufficient strength to –
  - 2.1.1 enable them to be safely lowered into the water when loaded with their full complement of persons and equipment; and
  - 2.1.2 be capable of being launched and towed when the ship is making headway at a speed of 5 knots in calm water.
- 2.2 An inflated rescue boat shall be constructed in such a way that, when suspended by its bridle or lifting hook –

- 2.2.1 it is of sufficient strength and rigidity to enable it to be lowered and recovered with its full complement of persons and equipment;
  - 2.2.2 it is of sufficient strength to withstand a load of 1.1 times the mass of its full complement of persons and equipment at an ambient temperature of  $-30^{\circ}\text{C}$  with all relief valves operative; and
  - 2.2.3 it is of sufficient strength to withstand a load of 4 times the mass of its full complement of persons and equipment at an ambient temperature of  $20\pm 3^{\circ}\text{C}$  with all relief valves inoperative.
- 2.3 Seating shall be provided on thwarts, benches or fixed chairs fitted as low as practicable in the boat and constructed so as to be capable of supporting the number of persons each weighing 100 kilogrammes for which spaces are provided in compliance with the requirements of paragraph 2.3.2 of Part 1.
- 2.4 Boats shall –
- 2.4.1 be not less than 3.8 metres and not more than 8.5 metres in length; and
  - 2.4.2 be capable of carrying at least 5 seated persons and a person lying down on a stretcher.
- 2.5 Boats shall be capable of manoeuvring at speeds of at least 6 knots and maintaining a speed of 6 knots for a period of at least 4 hours.
- 2.6 Boats shall be fitted with an inboard or outboard engine complying with the relevant parts of section 3 below.

### *Propulsion*

#### *Inboard engine*

- 3.1 Where a boat is powered by an inboard engine it shall be of the compression ignition type. No engine shall be used for any boat if its fuel has a flashpoint of  $43^{\circ}\text{C}$  or less (Closed Cup Test), and the engine shall –
- 3.1.1 be provided with either a manual starting system, or a power starting system with two independent rechargeable energy sources. Any necessary starting aids shall also be provided; the engine starting systems and starting aids shall start the engine at an ambient temperature of  $-15^{\circ}\text{C}$  within 2 minutes of commencing the start procedure unless, having regard to the particular voyages in which the ship carrying the boat is constantly engaged, a different temperature is appropriate; the starting systems shall not be impeded by the engine casing, thwarts or other obstructions;
  - 3.1.2 be capable of operating for not less than 5 minutes after starting from cold with the boat out of the water;
  - 3.1.3 be capable of operating when the boat is flooded up to the centreline of the crank shaft.

#### *Outboard engine*

- 3.2 Outboard engines using petrol or diesel oil as fuel shall be fitted with approved fuel systems. Petrol storage tanks shall be specially protected against fire and explosion. A starting system, which shall not be impeded by the engine casing, thwarts or other obstructions and which may include starting aids, shall be fitted and be capable of starting the engine –

- 3.2.1 at the ambient temperature and, within 2 minutes of commencing the starting procedure, at an ambient temperature of  $-15^{\circ}\text{C}$ , by manual means; or
- 3.2.2 at the ambient temperature by manual means and, within 2 minutes of commencing the starting procedure, by a powered starting system at an ambient temperature of  $-15^{\circ}\text{C}$ : except that if the ship on which the boat and its engine are carried, is constantly engaged on voyages where a different temperature is appropriate, that temperature may be substituted for  $-15^{\circ}\text{C}$ .
- 3.3 The boat engine, transmission and engine accessories shall be enclosed in a fire-retardant casing or other suitable arrangements providing similar protection. Such arrangements shall also protect persons from coming into accidental contact with hot or moving parts and protect the engine from exposure to weather and sea. Adequate means shall be provided to reduce the engine noise. Starter batteries shall be provided with casings which form a watertight enclosure around the bottom and sides of the batteries. Battery casings shall have tight fitting tops which provide for necessary gas venting.
- 3.4 Means shall be provided for recharging all engine-starting, searchlight and, when fitted, radio batteries. Radio batteries shall not be used to provide power for engine starting. Means shall be provided for recharging rescue boat batteries from the ship's power supply. The electric power supply connection from the ship to any inflated rescue boat shall be at a voltage not exceeding 55 volts direct current or 55 volts root mean square alternating current and shall be capable of being disconnected automatically at the inflated rescue boat embarkation station.

### *Fittings*

- 4.1 Boats shall be provided with a rudder and tiller or other suitable means of steering. When a wheel or other remote steering mechanism is also provided the alternative means shall be capable of steering the boat in the case of failure of the steering mechanism. Except where the rudder forms part of an outboard engine a rudder shall be permanently attached to the boat and a tiller shall be permanently installed on or linked to the rudder stock. However, if the boat has a remote steering mechanism the tiller may be removable and securely stowed near the rudder stock. The steering arrangements shall be so arranged so not to be damaged by operation of the release mechanism or the propeller.
- 4.2 Except in the vicinity of the rudder and propeller, a buoyant lifeline shall be becketed around the inside and outside of the boat.
- 4.3 Every boat shall be fitted with a release device to enable the forward painter to be released when under tension.
- 4.4 Boats intended for launching down the side of a ship shall have skates and fenders as necessary to facilitate launching and prevent damage to the boat.

### *Equipment*

- 5.1 In addition to the equipment required under Part 1 every inflated rescue boat shall be provided with –
- 5.1.1 sufficient buoyant oars or paddles to make headway in calm seas; thole pins, crutches or equivalent arrangements shall be provided for each oar; thole pins or crutches shall be attached to the boat by lanyards or chains;
- 5.1.2 a binnacle containing an efficient compass which is luminous or provided with suitable means of illumination;

- 5.1.3 a painter of sufficient length and strength, attached to the release device complying with the requirements of paragraph 4.3 and placed at the forward end of the boat;
  - 5.1.4 a searchlight with a horizontal and vertical sector of at least 6 degrees and a measured luminous intensity of 2500 candela which can work continuously for 3 hours;
  - 5.1.5 an efficient radar reflector;
  - 5.1.6 thermal protective aids sufficient for 10 per cent of the number of persons the boat is permitted to accommodate or two whichever is the greater; and
  - 5.1.7 a manually controlled lamp complying with the requirements of Part 2, paragraph 7.
- 5.2 Every cargo ship inflated rescue boat shall be so arranged that it can be boarded by its rescue complement of persons in not more than 3 minutes from the time the instruction to board is given. Rapid disembarkation shall also be possible.

*Access into boats*

- 6.1 In every passenger ship the boats shall be so arranged that they can be rapidly boarded by their rescue complement of persons. Rapid disembarkation shall also be possible.
- 6.2 In every cargo ship the boats shall be so arranged that they can be boarded by their rescue complement of persons in not more than 3 minutes from the time the instruction to board is given. Rapid disembarkation shall also be possible.

*Disengaging Gears*

- 7. Disengaging gear for inflated rescue boats shall comply with the requirements of section 8, Part 1 of Schedule 2.

Small Passenger Ship Regulations  
regs 5 and 6

Other Ships Regulations  
regs 44, 45, 47, 48  
65, 66, 68 and 69

**PART 3 – INFLATED BOATS  
(NON-SOLAS)**

*General*

- 1. Inflated boats shall comply with the requirements of Part 1 and in addition with the requirements of this Part.

*Construction*

- 2.1 A boat shall be constructed in such a way that, when suspended by its bridle or lifting hook
  - 2.1.1 it is of sufficient strength and rigidity to enable it to be lowered and recovered with all its equipment and a crew of 2 persons;
  - 2.1.2 it is of sufficient strength to withstand a load of 1.1 times the mass of its equipment and a crew of 2 persons at an ambient temperature of  $-30^{\circ}\text{C}$  with relief valves operative; and
  - 2.1.3 it is of sufficient strength to withstand a load of 4 times the mass of its equipment and a crew of 2 persons at an ambient temperature of  $20\pm 3^{\circ}\text{C}$  with all relief valves inoperative.

- 2.2 Boats shall be of sufficient strength to enable them to be safely lowered into the water when loaded with all their equipment and a crew of 2 persons.
- 2.3 At least one portable thwart shall be fitted to enable the boat to be rowed satisfactorily.
- 2.4 A boat shall –
  - 2.4.1 be not less than 3.8 metres and not more than 8.5 metres in length; and
  - 2.4.2 be capable of carrying at least 3 persons and a person lying down on a stretcher.
- 2.5 Boats shall be capable of manoeuvring at speeds of at least 6 knots in calm water with 2 persons on board and maintaining a speed of 6 knots for a period of at least 2 hours.
- 2.6 The boat shall be fitted with an outboard engine having a maximum power of 10 horsepower complying with the requirements of section 3.

### *Propulsion*

- 3.1 A petrol-driven outboard engine with an approved fuel system may be fitted, provided the tank is specially protected against fire and explosion.
- 3.2 A petrol engine shall be provided with a manual starting system. The engine starting system shall start the engine at an ambient temperature of  $-15^{\circ}\text{C}$  within 2 minutes of commencing the start procedure. The starting system shall not be impeded by the engine casing, thwarts or other obstructions.

### *Fittings*

- 4. Except in the vicinity of an outboard engine, a buoyant lifeline shall be becketed around the inside and outside of the boat.

### *Lifting Arrangements*

- 5.1 Bridle slinging arrangements shall be fitted to enable the boat to be lowered or raised from the water. The bridle sling shall comprise of at least four legs which should be joined at the top in the form of an eye or be connected to a lifting ring or shackle. The arrangement shall be such that the boat is stable when suspended and either –
  - 5.1.1 the length of the legs are of equal length; or
  - 5.1.2 the bridle is permanently attached; or
  - 5.1.3 it is not possible to connect any of the bridle legs to the wrong position in the boat.
- 5.2 The bridle shall be manufactured of a material which will not adversely affect the material of the boat and, if necessary, shall be sheathed to prevent abrasion of the fabric.
- 5.3 The forward lifting attachments shall be securely fastened to the hull and may be bands passing under the hull to the tops of the buoyancy tubes terminating in "D" rings or eyes to take bridle slings.
- 5.4 The after lifting attachments shall be similar to the forward attachments or may be made directly to the transom.
- 5.5 The bridle slinging arrangements used for lowering and recovering the boat shall be such that the breaking tensile strength is at least 6 times the sum of the mass of the boat, its full equipment and a crew of 2 persons each having a mass of 75 kilogrammes.

- 5.6 The bridle sling lifting arrangements shall be proof tested to not less than 4 times their respective working loads. The proof testing can be carried out either –
- 5.6.1 individually on each item associated with the lifting arrangements; or
  - 5.6.2 on the assembly of a structurally completed boat with its lifting arrangements and particular bridle sling. In each case, fabric webbings and cordages forming part of the lifting arrangements shall have a breaking strength of not less than 6 times their respective working loads.

### **Equipment**

6. In addition to the equipment required by Part 1, every inflated boat shall be provided with –
- 6.1 at least two buoyant oars or paddles to make headway in calm seas; crutches or equivalent arrangements shall be provided for each oar and shall be permanently attached to the boat.
  - 6.2 a painter 20 metres in length; and
  - 6.3 thermal protective aids sufficient for 10 per cent of the number of persons the boat is permitted to accommodate or two, whichever is greater.

In boats on passenger ships of Classes III to VI(A) the equipment specified in paragraph 6.3 need not be provided.

## SCHEDULE 4

### LIFERAFTS

#### PART 1 – GENERAL

##### *General*

1. Inflatable liferafts and rigid liferafts shall comply with the requirements of Schedule 1 and in addition shall comply with the requirements of this Part.

##### *Construction*

- 2.1 Every liferaft shall be so constructed as to be capable of withstanding exposure for 30 days afloat in all sea conditions without such deterioration as would involve any loss of seaworthiness.
- 2.2 The liferaft shall be so constructed that when it is dropped into the water in its container from a height of 18 metres, the liferaft and its equipment will operate satisfactorily. If the liferaft is to be stowed at a height of more than 18 metres above the waterline in the lightest seagoing condition, it shall be of a type which has been satisfactorily drop-tested from at least that height.
- 2.3 The floating liferaft shall be capable of withstanding repeated jumps on to it from a height of at least 4.5 metres above its floor both with and without the canopy erected.
- 2.4 The liferaft and its fittings shall be so constructed as to enable it to be towed at a speed of 3 knots in calm water when loaded with its full complement of persons and equipment and with one of its sea-anchors streamed.
- 2.5 The liferaft shall have a canopy to protect the occupants from exposure which is automatically set in place when the liferaft is launched and waterborne. The canopy shall comply with the following –
  - 2.5.1 it shall provide insulation against heat and cold by means of either two layers of material separated by an air gap or other equally efficient means; means shall be provided to prevent accumulation of water in the air gap;
  - 2.5.2 its interior shall be of a colour that does not cause discomfort to the occupants;
  - 2.5.3 each entrance shall be clearly indicated and be provided with efficient adjustable closing arrangements which can be easily and quickly opened from inside and outside the liferaft so as to permit ventilation but exclude seawater, wind and cold; liferafts accommodating more than 8 persons shall have at least two diametrically opposite entrances;
  - 2.5.4 it shall admit sufficient air for the occupants at all times, even with the entrances closed;
  - 2.5.5 it shall be provided with at least one viewing port if the liferaft is to accommodate less than 25 persons and at least two diametrically opposite viewing ports if it is to accommodate more than 25 persons;

- 2.5.6 it shall be provided with means for collecting rain water;
- 2.5.7 it shall have sufficient headroom for seated occupants under all parts of the canopy;  
and
- 2.5.8 it shall be provided with means to mount a survival craft radar transponder at a height of at least one metre above the sea.
- 2.6 No liferaft shall be approved which has a carrying capacity of less than 6 persons calculated in accordance with the requirements of paragraph 2.5 of Part 2 and of paragraph 2.2 of Part 3: except that in ships of Classes VIII(A), VIII(A)(T) and XI, in ships of Classes VIII and VIII(T) of less than 500 tons, in ships of class IX not being ships of 500 tons or over engaged on an international voyage and in ships of Class XII of 21.3 metres in length or over, the minimum carrying capacity of liferafts may be 4 persons, if the total number of persons on board is less than 5.
- 2.7 Unless the liferaft is to be launched by an approved launching appliance complying with the requirements of Part 3 of Schedule 6 or is not required to be stowed in a position providing for easy side to side transfer, and not required to be portable, the total mass of the liferaft, its container and its equipment shall not be more than 185 kilogrammes.

### *Fittings*

- 3.1 Lifelines shall be securely becketed around the inside and outside of the liferaft.
- 3.2 The liferaft shall be provided with arrangements for adequately siting and securing in the operating position the antenna provided with the portable radio apparatus where this is to be carried.
- 3.3 The liferaft shall be fitted with an efficient painter of length not less than 10 metres plus the distance from the stowed position to the waterline in the lightest seagoing condition, or 15 metres whichever is the greater.
- 3.4 The breaking strength of the painter system including its means of attachment to the liferaft except the weak link required by Part 8 shall be –
- 3.4.1 7.5 kilonewtons for liferafts accommodating up to 8 persons;
- 3.4.2 10.0 kilonewtons for liferafts accommodating 9 to 25 persons; and
- 3.4.3 15.0 kilonewtons for liferafts accommodating more than 25 persons or have a factor of safety of 3 in association with the requirement of paragraph 2.4 above whichever is the greater.
- 3.5 Entrances not provided with a boarding ramp shall have a boarding ladder, the lowest step of which shall be weighted and float at a level not less than 0.4 metres below the liferaft's light waterline.
- 3.6 There shall be means inside the liferaft to assist persons to pull themselves into the liferaft from the ladder.
- 3.7 The stability of the liferaft when loaded with its full complement of persons and equipment shall be such that it can be towed at speeds of up to 3 knots in calm water.
- 3.8 At least one manually controlled lamp complying with the requirements of Part 9 shall be fitted outside at the top of the liferaft canopy.

- 3.9 A manually controlled lamp complying with the requirements of Part 9 shall be fitted inside the liferaft.
- 3.10 Each inflatable liferaft shall be fitted with equipment complying with the relevant requirements of Part 6.

#### *Markings*

- 4.1 The liferaft shall be marked with the –
- 4.1.1 maker's name or trade mark;
  - 4.1.2 serial number;
  - 4.1.3 date of manufacture (month and year);
  - 4.1.4 name and place of servicing station where it was last serviced; and
  - 4.1.5 number of persons it is permitted to accommodate over each entrance in characters not less than 100 millimetres in height, of a colour contrasting with that of the liferaft canopy.
- 4.2 Provision shall be made for marking each liferaft with the name and port of registry of the ship to which it is to be fitted, in such a form that the ship identification can be changed at any time without opening the container.

#### *Instructions and Information*

- 5.1 Instructions and information shall be in a form suitable for the training manual and the instructions for on-board maintenance referred to in Schedule 14. Instructions and information shall be in English in a clear and concise form and shall include, as appropriate –
- 5.1.1 a general description of the liferaft and its equipment;
  - 5.1.2 the installation arrangements;
  - 5.1.3 operational instructions including use of associated survival equipment;
  - 5.1.4 survival instructions;
  - 5.1.5 emergency repair instructions;
  - 5.1.6 deployment, boarding and launching instructions;
  - 5.1.7 the method of release from within davit launched raft;
  - 5.1.8 the release from launching appliance;
  - 5.1.9 on-board maintenance requirements; and
  - 5.1.10 servicing requirements.

## PART 2 – INFLATABLE LIFERAFTS

### *General*

1. Every inflatable liferaft shall comply with the requirements of Part 1 and in addition shall comply with the requirements of this Part.

### *Construction*

- 2.1 The main buoyancy chamber shall be divided into –
  - 2.1.1 not less than two separate compartments, each inflated through a non-return inflation valve on each compartment;
  - 2.1.2 the buoyancy chambers shall be so arranged that in the event of one of the compartments being damaged or failing to inflate, the intact compartment shall be able to support, with positive freeboard over the liferaft's entire periphery, the number of persons which the liferaft is permitted to accommodate, each having a mass of 75 kilogrammes, and seated in their normal positions.
- 2.2 The floor of the liferaft shall be waterproof and shall be capable of being sufficiently insulated against cold either –
  - 2.2.1 by means of one or more compartments which the occupants can inflate, or which inflate automatically and can be deflated and reinflated by the occupants; or
  - 2.2.2 by other equally efficient means not dependent on inflation.
- 2.3 The liferaft shall be capable of being inflated by one person. The liferaft shall be inflated with a non-toxic gas by an inflation system. Inflation shall be completed within 1 minute at an ambient temperature of between 18°C and 20°C and within 3 minutes at an ambient temperature of –30°C. After inflation the liferaft shall maintain its form when loaded with its full complement of persons and equipment.
- 2.4 Each inflatable compartment shall be capable of withstanding a pressure at least 3 times the working pressure and shall be prevented from reaching a pressure exceeding twice the working pressure either by means of relief valves or by a limited gas supply. Means shall be provided for connecting the topping-up pump or bellows required by Part 6 so that the working pressure can be maintained.
- 2.5 The number of persons which a liferaft shall be permitted to accommodate shall be equal to the lesser of –
  - 2.5.1 the greatest whole number obtained by dividing by 0.096 the volume, measured in cubic metres, of the main buoyancy tubes (which for this purpose shall include neither the arches nor the thwarts if fitted) when inflated;
  - 2.5.2 the greatest whole number obtained by dividing by 0.372 the inner horizontal cross sectional area of the liferaft, measured in square metres, (which for this purpose may include the thwart or thwarts, if fitted) measured to the innermost edge of the buoyancy tubes; or
  - 2.5.3 the number of persons having an average mass of 75 kilogrammes, all wearing either immersion suits and lifejackets or, in the case of davit-launched liferafts, that can be seated with sufficient comfort and headroom without interfering with the operation of any of the liferaft's equipment.

## *Fittings*

- 3.1 At least one entrance shall be fitted with a semi-rigid boarding ramp capable of supporting a person weighing 100 kilogrammes to enable persons to board the liferaft from the sea. The boarding ramp shall be so arranged as to prevent significant deflation of the liferaft if the ramp is damaged. Liferafts accommodating more than 25 persons shall have at least two diametrically opposite entrances fitted with semi-rigid boarding ramps. In the case of davit-launched liferafts a boarding ramp shall not be fitted at the entrance where bowsing lines and embarkation facilities are fitted
- 3.2 The stability of liferafts capable of accommodating 25 persons or less when in the inverted position shall be such that they can be righted in a sea-way and in calm water by one person. Liferafts in excess of 25 persons capacity shall have righting facilities. The righting position of the liferaft shall be suitably marked and have a non-skid surface.
- 3.3 The liferaft shall be fitted with water pockets complying with the following requirements –
- 3.3.1 the cross-sectional area of the pockets shall be in the shape of an isosceles triangle with the base of the triangle attached to the underside of the liferaft;
  - 3.3.2 the design shall be such that the pockets fill to approximately 60 per cent of capacity within 15 to 25 seconds of deployment;
  - 3.3.3 the pockets shall have an aggregate capacity of at least 220 litres for inflatable liferafts up to and including the 10 person size;
  - 3.3.4 the pockets to be fitted on liferafts certified to carry more than 10 persons shall have an aggregate capacity of  $(20 \times N)$  litres, where N = number of persons the liferaft is certified to carry;
  - 3.3.5 the pockets shall be attached on all of their sides to the underside of the liferaft;
  - 3.3.6 the pockets shall be distributed symmetrically round the circumference of the liferaft either side of the carbon dioxide bottle with sufficient separation between each pocket to enable air to escape readily; and
  - 3.3.7 the pockets shall be of a highly visible colour.

## *Davit-launched inflatable liferafts*

- 4.1 In addition to the above requirements, a liferaft for use with an approved launching appliance complying with Part 3 of Schedule 6 shall –
- 4.1.1 when the liferaft is loaded with its full complement of persons and equipment, be capable of withstanding a lateral impact against the ship's side at an impact velocity of not less than 3.5 metres per second and also a drop into the water from a height of not less than 3 metres without damage that will affect its function;
  - 4.1.2 be provided with means for bringing the liferaft alongside the embarkation deck and holding it securely during embarkation. The distance between the liferaft and the bowsing line securing point shall be kept to a minimum to restrict movement of the liferaft during boarding; and
  - 4.1.3 when suspended from its lifting hook or bridle, withstand a load of –
    - 4.1.3.1 4 times the mass of its full complement of persons and equipment, at an ambient temperature and a stabilised liferaft temperature of  $20 \pm 3^{\circ}\text{C}$  with all relief valves inoperative; and

**4.1.3.2** 1.1 times the mass of its full complement of persons and equipment at an ambient temperature and a stabilised liferaft temperature of  $-30^{\circ}\text{C}$  with all relief valves operative.

- 4.2** Rigid containers for liferafts to be launched by a launching appliance shall be so secured that the container or parts of it are prevented from falling into the sea during inflation and launching of the liferaft.
- 4.3** Every passenger ship davit-launched liferaft shall be so arranged that it can be rapidly boarded by its full complement of persons.
- 4.4** Every cargo ship davit-launched, inflated liferaft shall be so arranged that it can be boarded by its full complement of persons in not more than 3 minutes from the time the instruction to board is given.

#### *Automatic self-righting inflatable liferafts*

- 5.1** Automatic self-righting inflatable liferafts shall comply with the requirements of Part 1 and of this Part except for the requirements of paragraphs 3.2, 4.1, 6.1 and 7.2.
- 5.2** The liferaft with all of its equipment and no persons on board shall automatically turn from a capsized position to an upright position on the surface of the water, regardless of whether it inflates in the inverted position underwater or on the surface of the water or capsizes for any reason following inflation.

#### *Canopied reversible inflatable liferafts*

- 6.1** Canopied reversible inflatable liferafts shall comply with the requirements of Part 1 and of this Part except for the requirements of paragraphs 3.2, 3.3, 4.1, 5.1 and 7.2.
- 6.2** The liferaft shall:
  - 6.2.1** be capable of being safely used at all times by untrained persons;
  - 6.2.2** be capable of operating safely whichever way up it is floating. The liferaft shall have a canopy on both sides of the main body, if applicable, of the liferaft, which shall be set in place when the liferaft is launched and waterborne. Both canopies shall meet the requirements of Part 1 paragraphs 2.5, 3.8 and 3.9.
  - 6.2.3** ensure that the equipment required under Part 6 shall be readily accessible whichever way up the canopied reversible liferaft is floating, either by use of an equipment container which is accessible from either side, or by duplication of equipment on each side of the liferaft; and
  - 6.2.4** ensure that the fully equipped canopied reversible liferaft with one person of 75 kilogrammes on board, shall float in a stable upright position in a seaway.

#### *Containers for inflatable liferafts*

- 7.1** The liferaft shall be packed in a container that is –
  - 7.1.1** so constructed as to withstand conditions encountered at sea;
  - 7.1.2** of sufficient inherent buoyancy, when packed with the liferaft and its equipment, to pull the painter from within and to operate the inflation mechanism should the ship sink; and
  - 7.1.3** as far as practicable watertight, except for drain holes in the container bottom.

- 7.2 The liferaft shall be packed in its container in such a way as to ensure, as far as possible, that the waterborne liferaft inflates in an upright position on breaking free from its container.
- 7.3 The container shall be marked with the –
- 7.3.1 maker's name or trade mark;
  - 7.3.2 serial number;
  - 7.3.3 number of persons it is permitted to carry;
  - 7.3.4 words "SOLAS 98";
  - 7.3.5 type of emergency pack enclosed;
  - 7.3.6 date when last serviced;
  - 7.3.7 length of painter;
  - 7.3.8 maximum permitted height of stowage above waterline (depending on drop-test height and length of painter); and
  - 7.3.9 launching instructions.

**Other Ships Regulations**  
regs 46, 48, 63, 64, 65, 66, 67, 68 and 69

### **PART 3 – RIGID LIFERAFTS**

#### *General*

1. Every rigid liferaft shall comply with the requirements of Part 1 and in addition with the requirements of this Part.

#### *Construction*

- 2.1 The buoyancy of the liferaft shall be provided by approved inherently buoyant material placed as near as possible to the periphery of the liferaft. The buoyant material shall be fire retardant or be protected by a fire-retardant covering.
- 2.2 The number of persons which a liferaft shall be permitted to accommodate shall be equal to the lesser of –
  - 2.2.1 the greatest whole number obtained by dividing by 0.096 the volume, measured in cubic metres, of the buoyancy material multiplied by a factor of 1 minus the specific gravity of that material;
  - 2.2.2 the greatest whole number obtained by dividing by 0.372 the horizontal cross-sectional area of the floor of the liferaft, measured in square metres; or
  - 2.2.3 the number of persons having an average mass of 75 kilogrammes, all wearing immersion suits and lifejackets, that can be seated with sufficient comfort and headroom without interfering with the operation of any of the liferaft's equipment.
- 2.3 The floor of the liferaft shall prevent the ingress of water and shall effectively support the occupants out of the water and insulate them from the cold.

### *Fittings*

- 3.1 At least one entrance shall be fitted with a rigid boarding ramp to enable persons to board the liferaft from the sea. In the case of a davit-launched liferaft having more than one entrance, the boarding ramp shall not be fitted at the entrance where bowing lines and embarkation facilities are fitted.
- 3.2 Unless the liferaft is capable of operating safely whichever way up it is floating, its strength and stability shall be such that it is either self-righting or can be readily righted in a sea-way and in calm water by one person.
- 3.3 The stability of a liferaft when loaded with its full complement of persons and equipment shall be such that it can be towed at speeds of up to 3 knots in calm water.

### *Markings*

- 4.1 In addition to the markings required by section 4 of Part 1, rigid liferafts shall be marked with the –
  - 4.1.1 name and port of registry of the ship to which it belongs;
  - 4.1.2 words "SOLAS 98";
  - 4.1.3 type of emergency pack enclosed;
  - 4.1.4 length of painter;
  - 4.1.5 date of manufacture (month and year);
  - 4.1.6 maximum permitted height of stowage above waterline (depending on drop-test height and length of painter); and
  - 4.1.7 launching instructions.

### *Davit-launched rigid liferafts*

- 5.1 A rigid liferaft for use with an approved launching appliance complying with Part 3 of Schedule 6 shall –
  - 5.1.1 when suspended from its lifting hook or bridle, withstand a load of 4 times the mass of its full complement of persons and equipment;
  - 5.1.2 when the liferaft is loaded with its full complement of persons and equipment, be capable of withstanding a lateral impact against the ship's side at an impact velocity of not less than 3.5 metres per second and also a drop into the water from a height of not less than 3 metres without damage that will affect its function; and
  - 5.1.3 be provided with means for bringing the liferaft alongside the embarkation deck and holding it securely during embarkation. The distance between the liferaft and the bowing line securing point shall be kept to a minimum to restrict movement of the liferaft during boarding.
- 5.2 Every passenger ship davit-launched liferaft shall be so arranged that it can be rapidly boarded by its full complement of persons.
- 5.3 Every cargo ship davit-launched liferaft shall be so arranged that it can be boarded by its full complement of persons in not more than 3 minutes from the time the instruction to board is given.

### *Automatic self-righting rigid liferafts*

- 6.1 Automatic self-righting rigid liferafts shall comply with the requirements of Part 1 and of this Part, except for the requirements of paragraphs 3.2, 5.1 and 7.1
- 6.2 The liferaft with all of its equipment and no persons on board shall automatically turn from a capsized position to an upright position on the surface of the water, regardless of whether it lands in the inverted position or capsizes for any reason following inflation.

### *Canopied reversible rigid liferafts*

- 7.1 Canopied reversible rigid liferafts shall comply with the requirements of Part 1 and of this Part except for the requirements of paragraphs 3.2, 5.1 and 6.1.
- 7.2 The liferaft shall:
  - 7.2.1 be capable of being safely used at all times by untrained persons.
  - 7.2.2 be capable of operating safely whichever way up it is floating. The liferaft shall have a canopy on both sides of the main body, if applicable, of the liferaft, which shall be set in place when the liferaft is launched and waterborne. Both canopies shall meet the requirements of Part 1 paragraphs 2.5, 3.8 and 3.9.
  - 7.2.3 ensure that the equipment required under Part 6 shall be readily accessible whichever way up the canopied reversible liferaft is floating, either by use of an equipment container which is accessible from either side, or by duplication of equipment on each side of the liferaft; and
  - 7.2.4 ensure that the fully equipped canopied reversible liferaft with one person of 75 kilogrammes on board, shall float in a stable upright position in a seaway.

Small Passenger Ship Regulations  
regs 5, 6, 7, 8 and 9

## **PART 4 – OPEN REVERSIBLE LIFERAFTS**

### *General*

- 1.1 Liferafts shall –
  - 1.1.1 be constructed with proper workmanship and materials;
  - 1.1.2 not be damaged in stowage in the air temperature range of  $-18^{\circ}\text{C}$  to  $+65^{\circ}\text{C}$ ;
  - 1.1.3 be capable of operating in the air temperature range of  $-18^{\circ}\text{C}$  to  $+65^{\circ}\text{C}$ , and a sea water temperature range of  $-1^{\circ}\text{C}$  to  $+30^{\circ}\text{C}$ ;
  - 1.1.4 be rot-proof, corrosion-resistant, and not be unduly affected by sea-water, oil or fungal attack; and
  - 1.1.5 be stable and maintain their shape when inflated and fully laden.

### *Construction*

- 2.1 The liferaft shall be so constructed that when it is dropped into the water in its container from a height of 10 metres, the liferaft and its equipment will operate satisfactorily. If the

liferaft is to be stowed at a height of more than 10 metres above the waterline in the lightest seagoing condition, it shall be of a type which has been satisfactorily drop-tested from at least that height.

- 2.2 The floating liferaft shall be capable of withstanding repeated jumps on to it from a height of at least 4.5 metres.
- 2.3 The liferaft and its fittings shall be so constructed as to enable it to be towed at a speed of 3 knots in calm water when loaded with its full complement of persons and equipment, with the sea anchor deployed.
- 2.4 The liferaft when fully inflated shall be capable of being boarded from the water whichever way up it inflates.
- 2.5 The main buoyancy chamber shall be divided into –
  - 2.5.1 not less than two separate compartments, each inflated through a non-return inflation valve on each compartment; and
  - 2.5.2 the buoyancy chambers shall be so arranged that in the event of one of the compartments being damaged or failing to inflate, the intact compartment shall be able to support, with positive freeboard over the liferaft's entire periphery, the number of persons which the liferaft is permitted to accommodate, each having a mass of 75 kilogrammes, and seated in their normal positions.
- 2.6 The floor of the liferaft shall be waterproof.
- 2.7 The liferaft shall be inflated with a non-toxic gas by an inflation system. Inflation shall be completed within 1 minute at an ambient temperature of between 18°C and 20°C and within 3 minutes at an ambient temperature of –18°C. After inflation the liferaft shall maintain its form when loaded with its full complement of persons and equipment.
- 2.8 Each inflatable compartment shall be capable of withstanding a pressure equal to at least 3 times the working pressure and shall be prevented from reaching a pressure exceeding twice the working pressure either by means of relief valves or by a limited gas supply. Means shall be provided for fitting the topping-up pump or bellows.
- 2.9 At least 25 per cent of the buoyancy tubes are to be of a highly visible colour. In this respect it will be acceptable if the water pockets required by paragraph 3.5 are manufactured in a highly visible colour.
- 2.10 The number of persons which a liferaft shall be permitted to accommodate shall be equal to the lesser of –
  - 2.10.1 the greatest whole number obtained by dividing by 0.075 the volume, measured in cubic metres, of the main buoyancy tubes (which for this purpose shall not include the thwarts if fitted) when inflated;
  - 2.10.2 the greatest whole number obtained by dividing by 0.304 the inner horizontal cross sectional area of the liferaft, measured in square metres (which for this purpose may include the thwart or thwarts, if fitted) to the innermost edge of the buoyancy tubes; or
  - 2.10.3 the number of persons having an average mass of 75 kilogrammes, all wearing lifejackets, that can be seated inboard of the buoyancy tubes without interfering with the operation of any of the liferaft's equipment.

- 2.11 No liferaft shall be approved with a carrying capacity of less than 4 or greater than 65 persons, calculated or determined in accordance with the requirements of paragraph 2.10.

### *Fittings*

- 3.1 Lifelines shall be securely becketed around the inside and outside of the liferaft.
- 3.2 The liferaft shall be fitted with an efficient painter of a length suitable for automatic inflation on reaching the water. For liferafts accommodating more than 30 persons an additional bowsing-in line is to be fitted.
- 3.3 The breaking strength of the painter system including its means of attachment to the liferaft except the weak link required by Part 8 shall be –
- 3.3.1 7.5 kilonewtons for liferafts accommodating up to 8 persons;
- 3.3.2 10.0 kilonewtons for liferafts accommodating 9 to 30 persons; and
- 3.3.3 15.0 kilonewtons for liferafts accommodating more than 30 persons.
- 3.4 The liferaft shall be fitted with at least the following number of inflated ramps to assist boarding from the sea whichever way up the raft inflates –
- 3.4.1 one boarding ramp for liferafts accommodating up to 30 persons; or
- 3.4.2 two boarding ramps for liferafts accommodating more than 30 persons.
- 3.5 The liferaft shall be fitted with water pockets complying with the following requirements –
- 3.5.1 the cross-sectional area of the pockets shall be in the shape of an isosceles triangle with the base of the triangle attached to the buoyancy tubes of the liferaft;
- 3.5.2 the design shall be such that the pockets fill to approximately 60 per cent of capacity within 15 to 25 seconds of deployment;
- 3.5.3 the pockets shall normally have aggregate capacity of between 125 litres and 150 litres for inflatable liferafts up to and including the 10 person size;
- 3.5.4 the pockets to be fitted to each buoyancy tube and on liferafts certified to carry more than 10 persons shall have as far as practicable an aggregate capacity of  $(12 \times N)$  litres, where  $N$  = number of persons the liferaft is certified to carry;
- 3.5.5 each pocket on a buoyancy tube should be attached so that when this pocket is in the deployed position it is attached along the full length of its upper edges to, or close to, the lowest point of the lowest buoyancy tube; and
- 3.5.6 the pockets shall be distributed symmetrically round the circumference of the liferaft with sufficient separation between each pocket to enable air to escape readily.
- 3.6 At least one manually controlled lamp complying with the requirements of Part 9 shall be fitted on the upper and lower surfaces of the buoyancy tubes.
- 3.7 Suitable automatic drainage arrangements are to be provided on each side of the floor of the liferaft in the following manner –
- 3.7.1 one for liferafts accommodating up to 30 persons; or
- 3.7.2 two for liferafts accommodating more than 30 persons.

- 3.8 The equipment of every liferaft shall consist of –
- 3.8.1 one buoyant rescue quoit, attached to not less than 30 metres of buoyant line with a breaking strain of at least 1.0 kiloNewtons;
  - 3.8.2 two safety knives of the non-folding type having buoyant handles are to be attached to the liferaft by light lines. They shall be stowed in pockets so that, irrespective of the way in which the liferaft inflates, they will be readily available on the top surface or the upper buoyancy tube in a suitable position to enable the painter to be readily cut;
  - 3.8.3 one buoyant bailer;
  - 3.8.4 two sponges;
  - 3.8.5 one sea-anchor permanently attached to the liferaft in such a way as to be readily deployable when the liferaft inflates. The position of the sea anchor should be clearly marked on both buoyancy tubes;
  - 3.8.6 two buoyant paddles;
  - 3.8.7 one first-aid outfit complying with the requirements of Schedule 13;
  - 3.8.8 one whistle or equivalent sound signal;
  - 3.8.9 two hand flares;
  - 3.8.10 one waterproof electric torch suitable for Morse signalling together with a spare set of batteries and a spare bulb in a waterproof container;
  - 3.8.11 one repair outfit for repairing punctures in buoyancy compartments; and
  - 3.8.12 one topping-up pump or bellows.
- 3.9 Liferafts equipped in accordance with paragraph 3.8 be marked in block capitals “E PACK”.
- 3.10 Where appropriate the equipment shall be stowed in a container which, if it is not an integral part of, or permanently attached to the liferaft, shall be stowed and secured to the liferaft and be capable of floating in water for at least 30 minutes without damage to its contents. Irrespective of whether the equipment container is an integral part of, or is permanently attached to, this open reversible liferaft, the equipment shall be readily accessible irrespective of which way up the open reversible liferaft inflates. The line which secures the equipment container to the liferaft shall have a breaking strain of 2 kiloNewtons or a breaking strain of 3:1 based on the mass of the complete equipment pack, whichever is the greater.

*Containers for open reversible inflatable liferafts*

- 4.1 The liferaft shall be packed in a container that is –
- 4.1.1 so constructed as to withstand conditions encountered at sea;
  - 4.1.2 of sufficient inherent buoyancy, when packed with the liferaft and its equipment, to pull the painter from within and to operate the inflation mechanism should the ship sink; and
  - 4.1.3 as far as practicable watertight, except for drain holes in the container bottom.

- 4.2 The container shall be marked with the –
- 4.2.1 maker's name or trade mark;
  - 4.2.2 serial number;
  - 4.2.3 number of persons it is permitted to carry;
  - 4.2.4 words "NON-SOLAS REVERSIBLE";
  - 4.2.5 type of emergency pack enclosed;
  - 4.2.6 date when last serviced;
  - 4.2.7 length of painter;
  - 4.2.8 maximum permitted height of stowage above waterline (depending on drop-test height); and
  - 4.2.9 launching instructions.

### *Markings*

- 5.1 The liferaft shall be marked with the –
- 5.1.1 maker's name or trade mark;
  - 5.1.2 serial number;
  - 5.1.3 date of manufacture (month and year);
  - 5.1.4 name and place of service station where it was last serviced; and
  - 5.1.5 number of persons it is permitted to accommodate on the top of each buoyancy tube in characters not less than 100 millimetres in height and of a colour contrasting with that of the tube.

### *Instructions and Information*

- 6.1 Instructions and information shall be in a form suitable for the training manual and the instructions for on-board maintenance referred to in Schedule 14. Instructions and information shall be in English in a clear and concise form and shall include, as appropriate –
- 6.1.1 a general description of the liferaft and its equipment;
  - 6.1.2 the installation arrangements;
  - 6.1.3 operational instructions including use of associated survival equipment;
  - 6.1.4 launching, deployment and boarding instructions; and
  - 6.1.5 servicing requirements.

## PART 5 – INFLATABLE LIFE RAFTS (NON-SOLAS)

### General

1. Liferrafts carried on board ships of Classes IX(A), IX(A)(T) and in ships of Class XII of less than 21.3 metres in length shall comply with the requirements of Part 1 and 2 provided that paragraphs 1.2 of Schedule 1, 2.2, 2.5.6, 2.6 and 3.3 of Part 1 and 2.3, 4.1.3.2 and 5.4.4 of Part 2 may be modified as follows –
  - 1.1 the drop height of 18 metres referred to in paragraph 2.2 of Part 1 may be 6 metres; if the liferaft is to be stowed at a height of more than 6 metres above the waterline in the lightest seagoing condition, it shall be of a type which has been satisfactorily drop-tested from at least that height;
  - 1.2 the means for collecting rain referred to in paragraph 2.5.6 of Part 1 need not be provided;
  - 1.3 the means for insulating the floor of the liferaft against cold as referred to in paragraph 2.6 of Part 2 need not be provided;
  - 1.4 the temperature of  $-30^{\circ}\text{C}$  referred to in paragraph 1.2 of Schedule 1, paragraph 2.3 and paragraph 4.1.3.2 of Part 2 may be  $-18^{\circ}\text{C}$ ;
  - 1.5 the minimum carrying capacity of liferafts required by paragraph 2.6 of Part 1 as 6 persons may be four provided that liferafts which are deemed fit to accommodate less than 6 persons shall only be carried on such ships on which the total number of persons on board is less than six;
  - 1.6 in determining a minimum length of a painter 10 metres shall be substituted for the 15 metres referred to in paragraph 3.3 of Part 1; and
  - 1.7 the container shall be marked with “DOT(UK) 98” in lieu of the marking required by paragraph 5.4.4 of Part 2.

Schedule 4 Part 1 and 2

## PART 6 – LIFERAFT EQUIPMENT (SOLAS)

- 1.1 Subject to the provisions of paragraph 1.3, 1.5, 1.7 and 1.9 the equipment of every liferaft shall consist of –
  - 1.1.1 one buoyant rescue quoit, attached to not less than 30 metres of buoyant line with a breaking strain of at least 1.0 kiloNewton;
  - 1.1.2 one safety knife of the non-folding type having a buoyant handle and stowed in a pocket on the upper buoyancy tube near the entrance adjacent to the painter and secured to the liferaft by a light line of sufficient length to enable the painter to be readily cut. In addition, a liferaft which is permitted to accommodate 13 persons or more shall be provided with a second safety knife which need not be of the non-folding type. The stowage position of the knives shall be highlighted;
  - 1.1.3 for a liferaft which is permitted to accommodate not more than 12 persons, one buoyant bailer; for a liferaft which is permitted to accommodate 13 persons or more, two buoyant bailers;

- 1.1.4 two sponges;
  - 1.1.5 two sea-anchors, one being spare and the other permanently attached to the liferaft in such a way as to be readily deployable when the liferaft inflates to enable the liferaft to lie oriented to the wind in the most stable manner;
  - 1.1.6 two buoyant paddles;
  - 1.1.7 three tin openers; and a pair of scissors. Safety knives containing special tin opener blades are satisfactory for this equipment. Scissors shall be of the safety type;
  - 1.1.8 one first-aid outfit complying with the requirements of Schedule 13;
  - 1.1.9 one whistle or equivalent sound signal;
  - 1.1.10 four rocket parachute flares;
  - 1.1.11 six hand flares;
  - 1.1.12 two buoyant smoke signals;
  - 1.1.13 one waterproof electric torch suitable for Morse signalling together with a spare set of batteries and a spare bulb in a waterproof container;
  - 1.1.14 an efficient radar reflector unless a radar transponder is stowed in the liferaft;
  - 1.1.15 one daylight signalling mirror with instructions on its use for signalling to ships and aircraft;
  - 1.1.16 one copy of the Department of Transport's Rescue Signal Table published by Her Majesty's Stationery Office;
  - 1.1.17 One set of fishing tackle;
  - 1.1.18 food ration complying with the requirements of Schedule 13 and totalling not less than 10,000 kilojoules for each person the liferaft is permitted to accommodate; these rations shall be stowed in a watertight container;
  - 1.1.19 watertight receptacles containing a total of 1.5 litres of fresh water complying with the requirements of Schedule 13 for each person the liferaft is permitted to accommodate, of which 0.5 litres per person may be replaced by a de-salting apparatus capable of producing an equal amount of fresh water in 2 days or 1 litre per person may be replaced by a manually powered reverse osmosis desalinator capable of producing an equal amount of fresh water in 2 days;
  - 1.1.20 one rust-proof drinking vessel graduated in millilitres;
  - 1.1.21 six doses of anti-seasickness medicine and one seasickness bag for each person the liferaft is permitted to accommodate;
  - 1.1.22 instructions printed in English on how to survive;
  - 1.1.23 instructions for immediate action; and
  - 1.1.24 thermal protective aids sufficient for 10 per cent of the number of persons the liferaft is permitted to accommodate, or two, whichever is the greater.
- 1.2 Liferafts equipped in accordance with paragraph 1.1 shall be marked in block capitals "SOLAS A PACK".

- 1.3 Liferafts carried on passenger ships engaged on short international voyages shall be provided with the equipment specified in paragraphs 1.1.1 to 1.1.6 inclusive, 1.1.8, 1.1.9, 1.1.13 to 1.1.16 inclusive and 1.1.21 to 1.1.24 inclusive and one half of the equipment specified in paragraphs 1.1.10 to 1.1.12 inclusive.
- 1.4 Liferafts equipped in accordance with paragraph 1.3 shall be marked in block capitals "SOLAS B PACK".
- 1.5 Liferafts carried on board ships of Classes IX(A) and IX(A)(T) shall be provided with the equipment specified in paragraphs 1.1.1 to 1.1.4 inclusive, 1.1.9, 1.1.13, 1.1.16, 1.1.22 and 1.1.23 and one half of the equipment specified in paragraph 1.1.5.
- 1.6 Liferafts equipped in accordance with paragraph 1.5 shall be marked in block capitals "C PACK".
- 1.7 Liferafts carried on board ships of Class XII of less than 21.3 metres in length shall be provided with the equipment specified in paragraphs 1.1.1 to 1.1.6 inclusive, 1.1.8, 1.1.9, 1.1.13, 1.1.15, 1.1.16, 1.1.17, 1.1.20 to 1.1.24 inclusive and one half of the equipment specified in paragraphs 1.1.10 to 1.1.12 inclusive together with the following equipment –
- 1.7.1 one safety tin opener;
- 1.7.2 one third of the food ration required by paragraph 1.1.18; and
- 1.7.3 watertight receptacles containing a total of 0.5 litres of fresh water for each person the liferaft is permitted to accommodate.
- 1.8 Liferafts equipped in accordance with paragraph 1.7 shall be marked in block capitals "D PACK".
- 1.9 Liferafts carried on board ships of Classes III, IV, V, VI and VI(A) may be provided with equipment specified in paragraphs 1.1.1, 1.1.4, 1.1.6, 1.1.8, 1.1.9 and 1.1.13 and two of the safety knives specified in 1.1.2, two buoyant bailers specified in 1.1.3 one sea anchor specified in 1.1.5 and two hand flares specified in 1.1.11.
- 1.10 Where appropriate the equipment shall be stowed in a container which, if it is not an integral part of, or permanently attached to, the liferaft, shall be stowed and secured inside the liferaft and be capable of floating in water for at least 30 minutes without damage to its contents. The line which secures the equipment container to the liferaft shall have a breaking strain of 2 kiloNewtons or a breaking strain of 3:1 based on the mass of the complete equipment pack, whichever is the greater.
- 1.11 In addition to the above requirements every inflatable liferaft shall be provided with –
- 1.11.1 one repair outfit for repairing punctures in buoyancy compartments; and
- 1.11.2 one topping-up pump or bellows.

Schedule 6 Part 1

## PART 7 – AUTOMATIC RELEASE HOOKS

### *Definitions*

1. In this Part the following definitions apply –

- 1.1 "actuating force" means the force required to set the actuating mechanism;

- 1.2 "actuating mechanism" means the mechanism which, when operated, allows the liferaft to be released automatically;
- 1.3 "automatic release mechanism" means the mechanism which opens the hook automatically to release the liferaft; and
- 1.4 "hook" means a hook to be used for the launching of liferafts which can be activated to automatically release the liferaft when it is waterborne.

#### *Functional criteria*

- 2.1 The hook shall be reliable and easily handled by one person during the preparation embarkation, launching and release of the liferaft.
- 2.2 The hook and its accessories shall be made of materials suitable for use in the marine environment.
- 2.3 A minimum factor of safety of 6 based on the ultimate strength of the materials used shall be applied to the design of all parts of the hook.
- 2.4 The lever for manual release and the actuating mechanism may be separate.
- 2.5 There shall be a clear and durable indicator to show if the actuating mechanism has been operated. The automatic release mechanism shall be such that positions between "safe" and "cocked" are not possible.
- 2.6 When the hook is in the automatic release position the liferaft shall be released as soon as it is waterborne. The release shall be immediate and complete. Means shall be provided to ensure that the hook does not open when the liferaft swings, bumps into the ship's side or is otherwise influenced by the wind during the lowering operation.
- 2.7 The hook shall be capable of release manually after launching. The manual release mechanism shall be designed having regard to the risk of unintentional release during the preparation, embarkation and lowering of the liferaft.
- 2.8 The release hook shall include a capability to release the hook under load. The on-load release control shall –
  - 2.8.1 be clearly differentiated from the control which activates the automatic release function;
  - 2.8.2 require at least two separate actions to operate;
  - 2.8.3 with a load of 150 kilogrammes on the hook, require a force of at least 600 and not more than 700 Newtons to release the load, or provide equivalent adequate protection against inadvertent release of the hook; and
  - 2.8.4 be designed such that the crew members on deck can clearly observe when the release mechanism is properly and completely set.

#### *Compatibility*

3. The operation of automatic release hooks shall be compatible with the type, size and manufacture of the inflatable liferafts carried, and this shall be established by operational tests before a particular combination of release hook and liferaft is acceptable.

## *Instructions and Information*

4. Instructions and information shall be in a form suitable for the training manual and the instructions for on-board maintenance referred to in Schedule 14. Instructions and information shall be in English in a clear and concise form and shall include a description of the operation and maintenance of the automatic release hook.

Small Passenger Ship Regulations  
reg 2

Other Ships Regulation  
regs 7, 8, 9, 51 and 72

## **PART 8 – FLOAT FREE ARRANGEMENTS**

### *General*

1. Float free arrangements shall provide for a liferaft to be released automatically in the event of a ship sinking.

### *Painter System*

2. The liferaft painter system shall provide a connection between the ship and the liferaft and shall be so arranged as to ensure that the liferaft when released, and in the case of an inflatable liferaft when inflated, is not dragged under by the sinking ship.

### *Hydrostatic Release Unit*

#### *Construction*

- 3.1 A hydrostatic release unit used in the float-free arrangements shall be so constructed that –
  - 3.1.1 the materials used are compatible and do not cause the unit to malfunction. No part of the release unit shall be galvanised or treated by other forms of metallic coating;
  - 3.1.2 there is adequate drainage to prevent the accumulation of water in the hydrostatic chamber when the unit is in its normal position;
  - 3.1.3 each part connected to the painter system has a strength not less than that required by the painter; and
  - 3.1.4 it can readily be removed for replacement or annual servicing.

#### *Materials and Components*

- 3.2 Materials and components shall be corrosion-resistant and not affected by seawater, oil or detergents.

#### *Performance*

- 3.3 A hydrostatic release unit shall –
  - 3.3.1 function properly in the air temperature range of  $-30^{\circ}\text{C}$  to  $+65^{\circ}\text{C}$ ;
  - 3.3.2 function properly in a seawater temperature range of  $-1^{\circ}\text{C}$  to  $+30^{\circ}\text{C}$ ;
  - 3.3.3 automatically release the liferaft at a depth of not more than 4 metres;
  - 3.3.4 not release prematurely when seas wash over the unit; and
  - 3.3.5 be capable of releasing a liferaft when the stowage is –

- 3.3.5.1 horizontal;
- 3.3.5.2 tilted 45 degrees and 100 degrees with the hydrostatic release unit at the upper side;
- 3.3.5.3 tilted 45 degrees and 100 degrees with the hydrostatic release unit at the lower side; or
- 3.3.5.4 vertical.

### *Marking*

- 3.4 A hydrostatic release unit shall be marked permanently on its exterior to identify its type and serial number and depth at which it will release the liferaft. In addition, if it is of a type which –
  - 3.4.1 requires servicing, it shall be marked with its date of manufacture and provided with a plate permanently attached to the unit for recording the date of servicing; and
  - 3.4.2 is disposable, with the date at which it must be replaced.

### *Instructions and Information*

- 3.5 Instructions and information must be in a form suitable for the training manual and the instructions for on-board maintenance referred to in Schedule 14. Instructions and information shall be in English in a clear and concise form and shall include –
  - 3.5.1 a general description of the unit;
  - 3.5.2 installation instructions;
  - 3.5.3 any on-board maintenance requirements; and
  - 3.5.4 servicing requirements.

### *Weak Link*

#### *Construction and Materials*

- 4.1 The weak link used in the float-free arrangements shall –
  - 4.1.1 be made from material which is corrosion resistant and not affected by seawater, oil or detergent;
  - 4.1.2 when made of cordage, have the ends either whipped or heat treated; and
  - 4.1.3 when made from flexible wire, have each end looped around a thimble and secured with a locking ferrule.

#### *Performance*

- 4.2 The weak link shall be of sufficient strength to –
  - 4.2.1 pull the painter out of the liferaft container;
  - 4.2.2 operate the liferaft inflation system; and
  - 4.2.3 break under a tensile force of between 1.8 and 2.6 kiloNewtons.

**PART 9 – LIFERAFT LIGHTS***General*

- 1.1 The lights shall be manually controlled but, in the case of an inflatable liferaft, operate automatically when the liferaft inflates and, in the case of a rigid liferaft, when the canopy is set in place.
- 1.2 Each light shall be connected independently to its own power source.
- 1.3 The external light may be of a flashing type.

*Construction*

- 2.1 The complete light unit shall be constructed with proper workmanship and materials.
- 2.2 It shall be capable of withstanding the drop-test on a liferaft without damage to the light or the liferaft.
- 2.3 It shall be capable of withstanding a drop of 2 metres on to a rigidly mounted steel plate or concrete surface.
- 2.4 It shall be rot-proof, corrosion-resistant, and not be unduly affected by seawater, oil or fungal growth.
- 2.5 It shall not deteriorate due to damp or humidity when stowed with a liferaft in its container.
- 2.6 The power source shall be a sea activated or dry chemical cell battery.
- 2.7 The power source shall be proofed against leakage of any chemicals which could damage or cause deterioration of any fabrics used in the construction of the liferaft.
- 2.8 The connection between light and power source shall be suitably protected.
- 2.9 The power source, in the inactive condition with the terminals covered, shall be capable of being immersed for 30 days in salt water without deterioration or loss of power.
- 2.10 The lamp holder and lens shall be so constructed as to prevent the ingress of water.
- 2.11 A flashing light shall not be fitted with a lens or curved reflector to concentrate the beam.

*Performance*

- 3.1 The lights shall have an operational endurance of not less than 12 hours.
- 3.2 They shall not be damaged in storage and shall operate in a satisfactory manner in the air temperature range  $-30^{\circ}\text{C}$  to  $+65^{\circ}\text{C}$ .
- 3.3 They shall operate in a satisfactory manner in a seawater temperature range of  $-1^{\circ}\text{C}$  to  $+30^{\circ}\text{C}$ .

- 3.4 They shall have a shelf life of not less than 3 years.
- 3.5 Internal lights shall be of sufficient luminous intensity to enable survival and equipment instructions to be read.
- 3.6 External lights shall be white with a luminous intensity of not less than 4.3 candela in all directions of the upper hemisphere.
- 3.7 It shall be visible through 360 degrees in a horizontal direction and, when attached to a liferaft, over as great a segment of the upper hemisphere as is practical.
- 3.8 In the case of a flashing light it shall flash at a rate of not less than 50 and not more than 70 flashes per minute for the 12 hour operating period with an equivalent effective luminous intensity required by paragraph 3.6.

*Markings*

- 4.1 The power source shall be marked externally with the –
  - 4.1.1 manufacturer's name or trade mark;
  - 4.1.2 type and batch number; and
  - 4.1.3 date of manufacture and expiry.
- 4.2 If the power source is a chemical pressurised cell it shall be clearly marked with a suitable warning notice.

## SCHEDULE 5

### MARINE ESCAPE SYSTEMS AND MEANS OF RESCUE SYSTEM

#### PART 1 – MARINE EVACUATION SYSTEM

##### *General*

- 1.1 A marine escape system shall provide a complete evacuation system for survivors, consisting of an inflatable escape chute, an inflatable floating boarding platform and a specified number of inflatable liferafts.
- 1.1.1 The passage of the marine evacuation system shall provide for safe descent of persons of various ages, sizes and physical capabilities wearing approved lifejackets from the embarkation station to the floating platform or survival craft.
- 1.2 The system shall comply with the requirements of Schedule 1 wherever applicable.
- 1.3 The system shall be –
- 1.3.1 sited clear of propellers and stabilisers;
  - 1.3.2 capable of removal for annual servicing;
  - 1.3.3 fitted with float free facilities complying with the requirements of Part 8 of Schedule 4 on those parts of the system intended for use as inflatable survival equipment;
  - 1.3.4 rapidly deployed by a single action using a gas inflation arrangement;
  - 1.3.5 provided with at least 50 per cent more gas than that required to inflate the system so that any loss of pressure sustained during a deployment can rapidly be replenished;
  - 1.3.6 provided, if the inflation system includes air aspiration, with the means of protecting the aspirator from damage and the ingress of water;
  - 1.3.7 capable of satisfactory operation in a sea-way; and
  - 1.3.8 capable of deployment by one person.

##### *Construction*

- 2.1 The container housing the escape chute and the boarding platform shall be –
- 2.1.1 strong enough to withstand the forces imposed upon it in severe weather conditions when the chute and platform is fully deployed and the maximum agreed number of fully loaded inflatable liferafts are attached to the platform. If the system is deployed using a support boom, then both the boom and the container shall be strong enough to safely withstand a load which is twice that imposed by the above conditions, without causing damage or distortion to either the boom or the container;
  - 2.1.2 suitably constructed on the outboard side to resist damage and to prevent ingress of water;

- 2.1.3 suitably protected on the inboard side to prevent damage or accidental deployment by unauthorised personnel;
  - 2.1.4 prominently labelled on the inboard side with clear deployment instructions;
  - 2.1.5 large enough to house the gas inflation system;
  - 2.1.6 provided with quick release of the outer door by a secure single-action arrangement;
  - 2.1.7 designed so that deployment of the system over the side will also activate the inflation arrangements;
  - 2.1.8 provided with a safe access to the top of the chute for those evacuating the ship;
  - 2.1.9 provided with a secure, manual release arrangement for the chute so that it can be jettisoned for additional buoyant support;
  - 2.1.10 fitted on board with portable securing arrangements so that it can be removed for annual servicing; and
  - 2.1.11 be provided with adequate drainage arrangements.
- 2.2 The escape chute which is part of the system shall –
- 2.2.1 consist of a single or double track slide with each track of sufficient width to prevent unrestricted evacuation by persons wearing an approved type of lifejacket;
  - 2.2.2 be of sufficient strength in its fully inflated condition to safely support a load of 300 kilogrammes (150 kilogrammes for a single track slide) at mid-length without bending or distorting;
  - 2.2.3 be sub-divided such that the loss of gas in any one compartment will not restrict its operational use as a means of evacuation;
  - 2.2.4 be provided with a slide path which will drain quickly and be safe to operate in wet conditions;
  - 2.2.5 be provided with vertically inflated panels on each side of the slide path of sufficient depth to permit safe evacuation in severe weather conditions; and
  - 2.2.6 be effectively connected to the chute container by arrangements which are capable of withstanding a load which is at least twice the load imposed in the maximum loaded condition.
- 2.3 The boarding platform, if fitted shall be –
- 2.3.1 stable in a seaway and provide a safe working area for those operating the system;
  - 2.3.2 self draining;
  - 2.3.3 sub-divided in such a way that the loss of gas from any one compartment will not restrict its operational use as a means of evacuation;
  - 2.3.4 of sufficient area that will provide for the securing of at least two liferafts for boarding and to accommodate at least the number of persons that at any time are expected to be on the platform. This usable platform area shall be at least equal to:

$$\frac{20\% \text{ of total number of persons that the marine evacuation system is certified for}}{4} \text{ m}^2$$

or 10 square metres whichever is the greater. Alternative arrangements may be approved subject to a demonstration that they comply with all the prescribed performance requirements;

- 2.3.5 such that sufficient buoyancy will be provided for the working load. In the case of an inflatable platform, the main buoyancy chambers, which for this purpose shall include any thwarts or floor inflatable structural members are to meet the requirements of Part 2, Schedule 4, based upon the platform capacity except that the capacity shall be obtained by dividing by 0.25 the usable area given in paragraph 2.3.4;
- 2.3.6 fitted with stabilising waterpockets designed in accordance with the standards stated in Part 2 of Schedule 4;
- 2.3.7 restrained by a bowsing line which is designed to deploy automatically as the system inflates so as to prevent it drifting to a position where it would be deployed at an angle of more than 45 degrees to the ship's side;
- 2.3.8 provided with mooring and bowsing line patches of sufficient strength to tie off the largest inflatable liferaft associated with the system; and
- 2.3.9 provided with a means of quick release from the chute and, if intended for use as an inflatable liferaft, comply with the appropriate requirements of Part 2 of Schedule 4.

*Performance of the System*

3. A marine escape system shall –

- 3.1 be capable of deployment by one person at the embarkation position;
- 3.2 not interfere with the deployment of any other life-saving equipment fitted in the ship;
- 3.3 be capable of transferring twice the number of persons it is designed to evacuate without significant deterioration of the slide paths;
- 3.4 be capable of satisfactory operation in a sea-way;
- 3.5 in the case of a passenger ship, be capable of transferring from the ship into the inflated liferafts the total number of persons for which the system is designed to evacuate within a period of 30 minutes and in the case of the cargo ship within 10 minutes from the time the abandon ship signal is given;
- 3.6 be capable of deployment from a passenger ship with a trim of up to 10 degrees and a list of up to 20 degrees either way;
- 3.7 In the case of being fitted with an inclined slide, such that the angle of the slide to the horizontal is –
  - 3.7.1 within a range of 30 degrees to 35 degrees when the ship is upright and in the lightest sea-going condition; and

- 3.7.2 in the case of a passenger ship, a maximum of 55 degrees in the final stage of flooding set by the requirements in Schedule 3, paragraph 2 of The Merchant Shipping Notice MSN 1698 (M).
- 3.8 evaluated for capacity by means of timed evacuation deployments conducted in harbour;
- 3.9 capable of providing a satisfactory means of evacuation in a sea state associated with a wind of force 6 on the Beaufort scale;
- 3.10 designed to, as far as practicable, remain effective under conditions of icing;
- 3.11 so constructed that only a minimum amount of routine maintenance is necessary. Any part requiring maintenance by the ship's crews shall be readily accessible and easily maintained; and
- 3.12 arranged such that liferafts may be securely attached to the platform and released from the platform by a person either in the liferaft or on the platform.

*Associated Inflatable Liferafts*

- 4. An inflatable liferaft used in conjunction with the marine escape system shall –
  - 4.1 conform with the requirements of Part 1 and Part 2 of Schedule 4 where applicable;
  - 4.2 be sited close to the system container but be capable of dropping clear of the deployed chute/slide and boarding platform;
  - 4.3 be capable of release from its stowage rack with arrangements which will enable it to be moored and inflated alongside the boarding platform;
  - 4.4 be capable of release from its stowage rack as an independent item of life-saving equipment;
  - 4.5 be provided with float free arrangements complying with the requirements of Part 8 of Schedule 4; and
  - 4.6 be provided with pre-connected or easily connected retrieving lines to the platform.

*Instructions and Information*

- 5. Instructions and information shall be in a form suitable for the training manual and in the instructions for on-board maintenance referred to in Schedule 14. Instructions and information shall be in English in a clear and concise form and shall include –
  - 5.1 a general description of the system;
  - 5.2 the installation arrangements;
  - 5.3 the operational instructions for the system, and associated survival craft;
  - 5.4 the on-board maintenance requirements; and
  - 5.5 the servicing requirements.

*Containers for marine evacuation systems*

- 6.1 The evacuation passage and platform shall be packed in a container that is –

- 6.1.1 so constructed as to withstand hard wear under conditions encountered at sea; and
  - 6.1.2 as far as practicable watertight, except for drain holes in the container bottom.
- 6.2 The container shall be marked with:
- 6.2.1 maker's name or trade mark;
  - 6.2.2 serial number;
  - 6.2.3 name of approval authority and the capacity of the system;
  - 6.2.4 SOLAS 1998;
  - 6.2.5 date of manufacture (month and year);
  - 6.2.6 date and place of last service;
  - 6.2.7 maximum permitted height of stowage above waterline; and
  - 6.2.8 stowage position on board.
- 6.3 Launching and operating instructions shall be marked on or in the vicinity of the container.

*Marking on marine evacuation systems*

- 7.1 The marine evacuation system shall be marked with –
- 7.1.1 maker's name or trade mark;
  - 7.1.2 serial number;
  - 7.1.3 date of manufacture (month and year);
  - 7.1.4 name of approving authority;
  - 7.1.5 name and place of servicing station where it was last serviced, together with the date of servicing; and
  - 7.1.6 the capacity of the system.

**PART 2 – TRAINING**

1. Facilities for crew training in the use of marine escape systems shall include –
- 1.1 the provision on board of an operational manual for the system and its associated inflatable liferafts;
  - 1.2 the provision of on-board training aids; and
  - 1.3 the provision ashore of a training course including, as far as is possible, practical exercises with full size equipment.

### PART 3 – MEANS OF RESCUE SYSTEM

1. The means of rescue system shall comply with the applicable requirements of Part 1 and also comply with the following requirements;
  - 1.1 the means of rescue shall provide for the safe transfer of persons rescued from the sea to the deck of the ship;
  - 1.2 the means of rescue shall provide an area of at least 9 square metres at water level to receive rescued persons;
  - 1.3 the means of rescue shall provide for the transfer of helpless persons to the deck of the ship;
  - 1.4 the rescue area into which the means of rescue is launched shall be adequately illuminated from the deck of the ship;
  - 1.5 the means of rescue shall be one of the following –
    - 1.5.1 a marine evacuation system complying with the requirements of Part 1, Schedule 5 providing a suitable floating platform, with a ladder or other means to ascend to the deck for able-bodied persons, and a mechanically powered means to safely hoist persons lying down. If a slide of a marine evacuation system is intended to provide the means of transfer from the platform to the deck of the ship for able-bodied persons, the slide shall be provided with suitable handholds or portable ladders with steps having an efficient non-slip surface;
    - 1.5.2 an appliance complying with the requirements for davit launched liferafts in Schedule 4, Part 1, paragraph 3.1; Part 2, paragraph 4.1.1 and Part 8, paragraph 1.1.1, and in the case of an inflatable appliance Schedule 4, Part 1, paragraphs 4.1 and 4.2; Part 2 paragraphs 2.1, 2.1.1, 2.1.2, 2.3, 2.4, 4.1.3, 4.1.3.1, 4.1.3.2 and 5.1 and Part 8 paragraph 1.12.1 or in the case of a rigid appliance Schedule 4, Part 1, paragraphs 4.1.1, 4.1.2 and 4.1.5 and Part 6, paragraphs 1, 2, 4.1.2, 4.1.6 and 5.1.1, to provide a suitable floating platform. The appliance shall be used with a liferaft launching appliance with a powered winch motor capable of raising the loaded appliance from the water to the deck of the ship with the total number of persons for which it is approved as a means of rescue at a rate of not less than 0.3 metres per second;
    - 1.5.3 the appliance provided for the launch and recovery of a fast rescue boat may be used as part of a means of rescue system provided it meets and does not conflict with any other relevant requirements.
  - 1.6 The means of rescue shall comply with the following –
    - 1.6.1 the appliance shall be of a highly visible colour, and shall be protected against damage when moving against the ship's side;
    - 1.6.2 the occupants shall be protected against injury caused by the launching appliance;
    - 1.6.3 two boarding ramps complying with Part 2, Schedule 4 paragraph 3.1 or Part 6, paragraph 3.1 shall be fitted;
    - 1.6.4 the floor shall be self-draining;
    - 1.6.5 suitable means shall be provided for bowing in the platform to the ship's side;

- 1.6.6** one knife of a type described in Part 8, Schedule 4 paragraph 1.1.2 shall be stowed in a pocket close to each bowing line attachment patch;
- 1.6.7** a special arrangement shall be fitted to close the gap between the loaded platform and the deck when the rescued persons board the ship;
- 1.6.8** the appliance shall be conspicuously marked to prevent confusion with liferafts;
- 1.6.9** if inflatable, the inflation system shall be quickly initiated by a manual control; and
- 1.6.10** means shall be provided for preventing occupants from falling from the platform on impact with the ship's side.

## SCHEDULE 6

### LAUNCHING APPLIANCES AND EMBARKATION LADDERS

#### PART 1 – GENERAL

##### *General Requirements*

- 1.1** With the exception of the secondary means of launching for free-fall lifeboats, each survival craft and rescue boat launching appliance, together with all its launching and recovery gear, shall be so arranged that the fully equipped survival craft or rescue boat it serves can be safely lowered at a list of up to 20 degrees either way and against a trim of up to 10 degrees –
- 1.1.1** after being boarded by its full complement of persons at the stowed position or from an embarkation deck, as appropriate; and
- 1.1.2** without persons in the survival craft or rescue boat.
- 1.2** Notwithstanding the requirements of paragraph 1.1, lifeboat launching appliances for oil tankers, chemical tankers and gas carriers with a final angle of heel greater than 20 degrees calculated, as appropriate, in accordance with –
- 1.2.1** regulation 29(3)(c) of the Merchant Shipping (Prevention of Oil Pollution) Regulations 1996 **(a)**;
- 1.2.2** paragraph 2.9.2.2 of the International Code for the Construction and equipment of Ships carrying Dangerous Chemicals in Bulk**(b)**; or
- 1.2.3** paragraph 2.9.1.2 of the International Code for the Construction and Equipment of Ships carrying Liquefied Gases in Bulk **(c)**;
- shall be capable of operating at the final angle of heel on the lower side of the ship taking into consideration the final damaged waterline of the ship.
- 1.3** Davits, winches, falls, blocks and all other launching gear shall comply with the requirements of Parts 2, 3 or 4.
- 1.4** On ships which regularly trade to Antarctica or North of the Arctic Circle or to sea areas where ice or icing-up conditions can be expected, each launching appliance shall, as far as practicable, remain effective under conditions of icing.
- 1.5** Every launching appliance for a lifeboat, rescue boat, liferaft or inflated boat shall be so constructed that a minimum amount of routine maintenance is necessary. All parts requiring regular maintenance by the ship's crew shall be readily accessible and easily maintained.
- 1.6** A launching appliance shall not depend on any means other than gravity or stored mechanical power which is independent of the ship's power supplies to launch the survival appliance or rescue boat it serves in, the fully loaded and equipped condition, and in the light condition. However, if the rescue boat is a dedicated rescue boat the mechanical power need not be independent of the ship's power supplies.

---

(a) S.I 1996/2154

(b) IMO Resolution MSC 4(48)

(c) IMO Resolution MSC 5(48)

## *Stresses*

2. Structural members and all blocks, falls, padeyes, links, fastenings and all other fittings used in connection with launching equipment shall be designed on the basis of a factor of safety calculated on the maximum working load assigned and the ultimate strength of the material used for construction. A minimum factor of safety of 4.5 shall be applied to the structural members of all davits and winches, and to bousing tackle and tricing pendants where they are required; and a minimum factor of safety of 6 shall be applied to falls, suspension chains, links and blocks.

## *Launching appliances using falls and a winch*

- 3.1 Launching appliances using falls and a winch, except for secondary launching appliances for free-fall lifeboats, shall also comply with the following:
  - 3.2 An efficient hand gear shall be provided to recover each survival craft, rescue boat and fast rescue boat.
  - 3.3 Where davit arms are recovered by power, safety devices shall be fitted which will automatically cut the power off before the arms reach their stops in order to avoid overstressing the falls or davits, unless the motor is designed to prevent such overstressing.
  - 3.4 A lifeboat launching appliance shall be capable of recovering and stowing the lifeboat with its launching crew.
  - 3.5 Every survival craft, rescue boat and fast rescue boat launching appliance shall be fitted with brakes, or equivalent devices, capable of stopping the descent of the survival craft or rescue boat and holding it securely when loaded with its full complement of persons and equipment; brake pads shall, where necessary, be protected from water and oil.
  - 3.6 Manual brakes shall be so arranged that the brake is always applied unless the operator, or a mechanism actuated by the operator, holds the brake control in the "OFF" position.
  - 3.7 Every rescue and fast rescue boat launching appliance shall be fitted with a winch motor of such capacity that the rescue boat, or a lifeboat if it has been accepted as a rescue boat, can be raised from the water with its full rescue boat complement of persons and equipment to a position where the persons can be safely disembarked.
  - 3.8 Rescue boat launching and recovery appliances arrangements shall –
    - 3.8.1 be capable of hoisting the rescue boat, or a lifeboat in rescue boat mode, when loaded with its full rescue boat complement of persons and equipment at a rate of not less than 0.3 metre per second;
    - 3.8.2 except in the case where a rescue boat is fitted with a single point suspension, every rescue boat shall be provided with the means for facilitating the attachment of the lower fall blocks to the lifting arrangements of the boat when the boat is recovered from the sea in adverse weather conditions. For this purpose a recovery strop of adequate strength and suitable length shall be provided for each davit, and one end of the strop shall be attached to the lower fall block and the other end to the lifting arrangement on the boat. In addition means shall be provided for hanging off the boat after hoisting to enable the lower fall block to be attached directly to the lifting hook.
  - 3.9 Fast rescue boat launching and recovery arrangements shall comply with the requirements of this Part as applicable and –

- 3.9.1 the launching appliance shall be fitted with a device to dampen the forces due to interaction with the waves when the fast rescue boat is launched or recovered. The device shall include a flexible element to soften shock forces and a damping element to cancel out oscillations;
- 3.9.2 the winch shall be fitted with an automatic high-speed tensioning device which prevents the wire from going slack in all sea state conditions in which the fast rescue boat is intended to operate;
- 3.9.3 the winch brake shall have a gradual action. When the fast rescue boat is lowered at full speed and the brakes are applied sharply the additional dynamical force induced in the wire due to retardation should not exceed 0.5 times the working load of the launching appliance;
- 3.9.4 the lowering speed for a fully equipped fast rescue boat with its full complement of persons on board shall not exceed 1 metre per second, the hoisting speed when lifting the fully equipped rescue boat loaded with 6 persons shall be not less than 0.8 metres per second. The appliance shall also be capable of lifting the rescue boat with the maximum number of persons that can be accommodated in the rescue boat as calculated under Part 2, Schedule 2 paragraph 2.3;
- 3.9.5 at least three turns of wire shall remain on the winch after the fast rescue boat is lowered to the sea with the ship at its lightest seagoing condition, a trim of up to 10 degrees and a list of up to 20 degrees, either way;
- 3.9.6 These arrangements shall take into account that the fast rescue boat is intended to be safely launched and retrieved even under severe adverse weather conditions.

#### *Wire ropes*

- 4.1 Falls shall be of rotation-resistant and corrosion-resistant steel wire rope.
- 4.2 The breaking tensile load of each wire rope used for lowering lifeboats, rescue boats, fast rescue boats, liferafts or inflated boats shall be not less than 6 times the maximum load on the wire rope when lowering, hoisting or stowing.
- 4.3 Wire ropes shall be securely attached to the drum of the winch, and the end attachments of the wires and other parts from which the craft is to be suspended shall be capable of withstanding a proof load of not less than 2.2 times the load on such attachments and other parts.
- 4.4 Where wire rope splices or ferrule-secured eye terminals are used they shall be capable of withstanding a proof test of not less than 2.2 times the load imposed on them in service.
- 4.5 Survival craft attached to davits shall have the falls ready for service, and the falls shall be at least long enough to reach the water with the ship at her lightest sea-going draught under unfavourable conditions of trim and listed to 20 degrees either way. Disengaging gear complying with the requirements of Part 1 of Schedule 2, shall be provided for detaching the lifeboat or rescue boat from the falls.

#### *Winches*

- 5.1 In the case of a multiple drum winch, unless an efficient compensatory device is fitted, the falls shall be so arranged to wind off the drums at the same rate when lowering, and to wind on the drums evenly at the same angle when hoisting. The lead blocks shall be arranged to give a fleet angle or angle of lead of not more than five degrees for grooved drums and three degrees for ungrooved drums. In the case of mechanically controlled single-arm davits, the lead of the wire rope fall shall be such that the fall winds evenly on the drum.

- 5.2 Winch brakes shall be of robust construction and be capable of controlling and limiting the speed a boat is lowered. The hand brake shall be so arranged that it is normally in the "ON" position and returns to the "ON" position when the control handle is not being operated. The mass of the brake lever shall be sufficient to operate the brake effectively without additional pressure. The winch brakes shall be of sufficient strength to withstand –
- 5.2.1 a static test with a proof load of not less than 1.5 times the maximum working load; and
- 5.2.2 a dynamic test with a proof load of not less than 1.1 times the maximum working load at maximum lowering speed.
- 5.3 The speed at which a fully laden lifeboat, rescue boat, liferaft or inflated boat with its equipment and launching crew is lowered into the water shall be not less than that obtained from the formula –
- $$S = 0.4 + (0.02 \times H)$$
- where S = speed of lowering in metres per second, and
- H = height in metres from davit head, at the outboard position, to the waterline at the lightest seagoing condition.
- In the case of a lifeboat, rescue boat or inflated boat where "H" exceeds 30 metres the lowering speed need not exceed 1 metre per second. In the case of a liferaft where "H" exceeds 15 metres the lowering speeds need not exceed 0.7 metres per second.
- 5.4 Notwithstanding the requirements of paragraph 5.3 the speed of lowering a lifeboat, rescue boat or inflated boat shall not exceed 1.3 metres per second. The speed of lowering a liferaft shall not exceed 1 metre per second.
- 5.5 The speed of lowering survival craft, fully equipped but without persons on board, shall be at least 70 per cent of that required by paragraph 5.3.
- 5.6 The brake gear of the winch shall include the means for automatically controlling the speed of lowering to within the limits specified in paragraphs 5.3 and 5.4. A ratchet gear shall be incorporated in these winches.
- 5.7 Hand gear handles shall not be rotated by moving parts of the winch when the lifeboat or rescue boat is being lowered or when it is being hoisted by power. Provision shall be made to allow the falls to be manually unwound.
- 5.8 The launching mechanism shall be so arranged that it may be actuated by one person from a position on the ship's deck and, except for secondary launching appliances for free-fall lifeboats, from a position within the survival craft or rescue boat. When launched by a person on the deck, the launching and recovery arrangements shall be such that the winch operator on the ship's deck is able to observe the craft at all times during launching and recovery.
- 5.9 In this case of a liferaft, if the lowering is actuated from within the raft by means of a control wire paid off from an auxiliary drum on the winch –
- 5.9.1 the mass of the control wire shall be sufficient to overcome the friction of the various pulleys on the control wire;
- 5.9.2 the winch brake shall be operable from within the liferaft;

- 5.9.3 the winch brake shall not be affected by the mass of the fully extended control wire nor the wind effects on it; and
  - 5.9.4 there shall be sufficient length of control wire available at the craft during all stages of lowering.
- 5.10 When the lowering of the lifeboat or rescue boat is controlled from within the craft by means of a control wire paid off from an auxiliary drum on the winch –
- 5.10.1 the mass of the control wire shall be sufficient to overcome the friction of the various pulleys on the control wire, when turning out the lifeboat or rescue boat from the stowed position;
  - 5.10.2 the winch brake shall be operable from within the boat;
  - 5.10.3 the winch brake shall not be affected by the mass of the fully extended control wire, nor the wind effects on it;
  - 5.10.4 there shall be sufficient length of control wire available at the boat during stages of lowering; and
  - 5.10.5 means shall be provided to retain the free end of the control wire in the boat until the boat is detached from the falls.

*Float-free launching*

6. Where a survival craft requires a launching appliance and is also designed to float free, the float-free release of the survival craft from its stowed position shall be automatic.

*Free-fall launching*

- 7.1 Every free-fall launching appliance using an inclined plane shall, in addition to complying with the applicable requirements of paragraph 1 also comply with the following requirements –
- 7.1.1 the launching appliance shall be so arranged that excessive forces are not experienced by the occupants of the survival craft during launching;
  - 7.1.2 the launching appliance shall be a rigid structure with a ramp angle and length sufficient to ensure that the survival craft effectively clears the ship;
  - 7.1.3 the launching appliance shall be efficiently protected against corrosion and be so constructed as to prevent incendive friction or impact sparking during the launching of the survival craft;
  - 7.1.4 The launching appliance shall be designed and arranged so that in its ready to launch position, the distance from the lowest point on the lifeboat it serves to the water surface with the ship in its lightest seagoing condition does not exceed the lifeboat's free-fall certification height taking into consideration the requirements of paragraph 3, Part 9, Schedule 2;
  - 7.1.5 The launching appliance shall be arranged so as to preclude accidental release of the lifeboat in its unattended stowed position. If the means provided to secure the lifeboat cannot be released from inside the lifeboat, it shall be so arranged as to preclude boarding the lifeboat without first releasing it;
  - 7.1.6 The release mechanism shall be arranged so that at least two independent actions from inside the lifeboat are required in order to launch the lifeboat;

- 7.1.7 Each launching appliance shall be provided with a secondary means to launch the lifeboat by falls. Such means shall comply with the requirements of Section 1 except paragraph 1.6 and Section 3 except paragraph 3.2. It must be capable of launching the lifeboat against unfavourable conditions of trim of up to only 2 degrees and list of up to only 5 degrees either way and it need not comply with the speed requirements of paragraphs 5.3 and 5.4. If the secondary launching appliance is not dependent on gravity, stored mechanical power or other manual means, the launching appliance shall be connected both to the ship's main and emergency power supplies; and
- 7.1.8 The secondary means of launching shall be equipped with at least a single off-load capability to release the lifeboat.

*Evacuation- passage launching and embarkation*

8. Every evacuation-passage launching appliance shall, in addition to complying with the applicable requirements of paragraph 1, also comply with the requirements of Schedule 5.

*Means of rescue launching and embarkation*

9. Every means of rescue launching and recovery appliance shall; in addition to complying with the applicable requirements of Part 1; also comply with the requirements of Part 3, Schedule 5.

*Instructions and Information*

- 10.1 Instructions and information shall be in a form suitable for the training manual and in the instructions for on-board maintenance referred to in Schedule 14. Instructions and information shall be in English in a clear and concise form and shall include the following –
- 10.1.1 a description of launching appliance and winch, were provided;
- 10.1.2 the operation for launching and recovery; and
- 10.1.3 the maintenance required.

Small Passenger Ship Regulations  
regs 5 and 6

Other Ships Regulations  
regs 7, 8, 9, 42, 43, 44, 45, 46, 47  
63, 64, 65, 66, 68 and 69

**PART 2 – LIFEBOAT AND RESCUE BOAT LAUNCHING APPLIANCES**

*General*

- 1.1 Every lifeboat, rescue boat and fast rescue boat launching appliance shall comply with the requirements of Part 1 as is applicable to it and, in addition, shall comply with the requirements of this Part.
- 1.2 In this Part the expression “working load” means –
- 1.2.1 in relation to davits to which paragraphs 2.1 and 2.2 apply, the sum of the weight of the lifeboat and its full equipment, the blocks and falls, and the maximum number of persons which the lifeboat is deemed fit to carry, the weight of each person being taken to be 75 kilogrammes; and
- 1.2.2 in relation to winches, the maximum pull exerted by the fall or falls at the winch drum during lowering, hoisting or stowing which in any case is to be taken as not less than the working load on the davit or davits divided by the velocity ratio of the lowering tackle.

## *Construction*

- 2.1 The arrangements of the davits shall be such as to enable safe boarding of the lifeboat in accordance with the requirements of paragraph 2.4 and 2.5 of Part 2 of Schedule 2.
- 2.2 If partially enclosed lifeboats are carried, a davit span shall be provided, fitted with not less than two lifelines of sufficient length to reach the water with the ship in its lightest seagoing condition, under unfavourable conditions of trim and with the ship listed not less than 20 degrees either way.

## *Strength*

- 3.1 Every davit serving a lifeboat which is required to be boarded and launched from the stowed position and put into the water when loaded with its full complement of persons shall, together with its winch, falls, blocks and all other associated equipment, be of such strength that the lifeboat with its full equipment can be turned out and then safely lowered into the water from the stowed position with its full complement of persons, when the ship has a list of up to 20 degrees either way and a trim up to 10 degrees or such greater angles as may be required under paragraph 1.2 of Part 1.
- 3.2. Every davit serving a lifeboat which is required to be boarded and launched from an embarkation position and put into the water when loaded with its full complement of persons shall, together with its winch, falls, blocks and all other associated lowering gear, be of such strength that the lifeboat with its full equipment and manned by a launching crew of not less than 2 persons can be turned out and then safely lowered into the water from the embarkation position with its full complement of persons, when the ship has a list of up to 20 degrees either way and a trim of up to 10 degrees.
- 3.3 Every set of davits, davit or other means of launching to which a lifeboat is attached, together with its winch and associated gear shall be of such strength that the lifeboat can be hoisted with launching crew of at least 3 persons and its full equipment at a rate of not less than 0.05 metre per second when a powered winch is fitted. When an unpowered winch is fitted the hoisting rate shall be not less than 0.01 metre per second.
- 3.4 Every set of davits, davit or other means of launching to which a rescue boat is attached shall be fitted with a powered winch and shall, together with its associated gear, be of such strength that the boat to which it is attached can be hoisted when loaded with its full rescue boat complement of persons and equipment at a rate of not less than 0.3 metre per second. When a lifeboat is designated as a rescue boat, the davits, davit or other means of launching shall be capable of hoisting the boat to a disembarkation position at a rate of not less than 0.3 metre per second when loaded with its full rescue boat complement, or 6 persons whichever is the greater, and its full lifeboat equipment.
- 3.5 Every fast rescue boat launching and recovery arrangement shall incorporate a powered winch, dampening devices and braking requirements described in Part 1 paragraph 3.9 and be capable of lowering the fully equipped boat with its full complement of persons at a speed not exceeding 1 metre per second and hoisting the fully equipped boat loaded with 6 persons at a speed of at least 0.8 metres per second. The arrangement shall also be capable of lifting the rescue boat with the maximum number of persons accommodated. The complete arrangement shall be of adequate strength to withstand the stresses developed in the system carrying out these operations safely under severe adverse weather conditions.

## *Gravity davits*

4. All gravity davits shall be so designed that there is a positive turning out moment during the whole of the davit travel from the inboard to the outboard position when the vessel is upright and also when the vessel is listed at any angle up to and including 30 degrees either way from upright, or 10 degrees more than the angle required by paragraph 1.2 of Part 1. In the case of gravity type davits

comprising arms mounted on rollers which engage with and travel down fixed inclined trackways, the trackways shall be inclined at an angle of not less than 35 degrees to the horizontal when the vessel is upright.

#### *Luffing davits*

- 5 The operating gear of luffing davits shall be of sufficient power to ensure that the lifeboats or rescue boats fully equipped and carrying –

5.1.1 the total number of persons they are certified to carry; or

5.1.2 a launching crew of not less than 2 persons when boarded from a stowed position or embarkation deck;

can be turned out against a list of at least 20 degrees.

#### *Static load test*

6. Each davit arm and its attachments, except the winch brakes, shall be capable of withstanding a static load test when in the outboard position, of at least 2.2 times the maximum load designed to be supported by that arm.

#### *Attachments at the davit head*

7. The attachments at the davit head from which the blocks are suspended shall be capable of withstanding a proof load test of not less than 2.2 times the maximum load on them.

#### *Blocks*

8.1 Lower blocks, when fitted, shall be non-toppling. In the case of rescue boats provision shall be made to prevent the falls from cabling. The size of blocks shall be commensurate with the size of the falls.

8.2 The blocks shall be capable of withstanding a proof load test of not less than 2.2 times the maximum load it is intended to carry in service. The clearance between the sheaves and the cheeks of the blocks in which wire rope is used shall be kept to a practical minimum to prevent the rope from overriding the rim of the sheave of any block or load sheave. Component parts of blocks other than their sheaves shall be of ductile material.

Small Passenger Ship Regulations  
regs 5 and 6

Other Ships Regulations  
regs 7, 8, 9, 42, 43, 44, 45  
63, 64, 65 and 66

### **PART 3 – LIFERAFT LAUNCHING APPLIANCES**

#### *General*

1.1 Every launching appliance shall comply with the requirements of Part 1 as is applicable to it and in addition shall comply with the requirements of this Part.

1.2 In this Part the expression “working load” means the sum of the mass of the liferaft and its equipment, all other associated gear that is supported by the launching appliance during the lowering operation and the maximum number of persons which the liferaft is deemed fit to carry, the mass of each person being taken to be 75 kilogrammes.

1.3 The arrangements of the launching appliance shall be such as to enable safe boarding of the liferaft in accordance with the requirements of paragraph 4.3 and 4.4 of Part 2 of Schedule 4.

### **Strength**

2. Every launching appliance serving a liferaft which is required to be put into the water when loaded with its full complement of persons shall, together with its winch, falls, blocks and all other associated launching equipment, be of such strength that the liferaft with its full equipment can be safely lowered into the water from the embarkation position with its full complement of persons, when the ship has a list of up to 20 degrees either way and a trim of up to 10 degrees, or such higher angle as may be required by paragraph 1.2 of Part 1.

### **Static load test**

3. Every launching appliance and its attachments, except the winch brakes, shall be capable of withstanding a static load test when in the full outboard position, of at least 2.2 times the maximum designed working load.

### **Release of the liferaft**

4. The launching appliance shall be so arranged as to prevent premature release during the lowering of the liferaft but shall be such that on becoming waterborne the raft shall be automatically released from the release hook which shall comply with requirements of Part 7 of Schedule 4.

Small Passenger Ship Regulation  
regs 5 and 6

Other Ships Regulations  
regs 42, 43, 44, 46, 47  
63, 64, 65, 67 and 68

## **PART 4 – INFLATED BOAT LAUNCHING APPLIANCES**

### **General**

- 1.1 Every inflated boat launching appliance shall comply with the requirements of Part 1 as is applicable to it and in addition with the requirements of this Part.
- 1.2 In this Part the expression “working load” means the weight of –
  - 1.2.1 the inflated boat and its full equipment;
  - 1.2.2 the blocks and falls;
  - 1.2.3 a launching crew of 2 persons each of mass 75 kilogrammes; and
  - 1.2.4 a weight of 60 kilogrammes or the engine together with its fuel tank and sufficient fuel for two hours operation, whichever is the greater.
- 1.3 In this Part the expression “inflated boat” means any inflated boat or rigid inflated boat other than a dedicated rescue boat.

### **Construction**

2. Every inflated boat launching appliance shall be so constructed to be –
  - 2.1 capable of recovering the inflated boat and bringing it on board the ship;
  - 2.2 readily available and not stowed or used for any purpose other than the launching of the inflated boat whilst the ship is at sea; and
  - 2.3 provided with a suitable means for manual operation.

### ***Strength***

3. Every launching appliance serving an inflated boat shall, together with its winch if fitted, falls, blocks and other associated lowering gear, be of such strength that the inflated boat with its full equipment can be safely lowered into the water from the embarkation position with a complement of 2 persons, when the ship has a list of up to 20 degrees either way and a trim of up to 10 degrees.

### ***Static load test***

4. Every launching appliance and its attachments, except the winch brakes, shall be capable of withstanding a static load test when in the full outboard position of at least 2.2 times the maximum designed working load.

### ***Winches***

5. Every such launching appliance shall be provided with a winch when the inflated boat is situated more than 4.5 metres above the lightest sea going waterline.

### ***Cordage rope falls***

- 6.1 Cordage rope falls shall be of manila or some other suitable material and shall be durable, uninkable, firm laid and pliable. They shall be able to pass freely under any conditions through a hole 10 millimetres larger than the nominal diameter of the rope. The breaking load of each rope used for lowering inflated boats shall be not less than 6 times the maximum load on the rope when lowering or hoisting. Winding reels or flaking boxes for the manila rope falls shall be provided.
- 6.2 Such falls shall be at least long enough to reach the water with the ship at her lightest seagoing condition and listed to 20 degrees either way.

### ***Bollards***

7. Suitable bollards or other equally effective appliances for lowering any inflated boat shall be provided in all cases where cordage rope falls are used. Such bollards or other appliances shall be sited so as to ensure that the inflated boat served by them can be safely lowered, the fairleads or lead sheaves shall be fitted so as to ensure that it shall not be lifted during the process of turning out or swinging out.

Small Passenger Ship Regulations  
reg 13

Other Ships Regulations  
regs 50 and 71

## **PART 5 – EMBARKATION LADDERS**

### ***Construction***

- 1.1 The steps of the three string embarkation ladder applicable for Class III to VI(A) shall be –
  - 1.1.1 made of hardwood, free from knots or other irregularities, smoothly machined and free from sharp edges and splinters, or of suitable material of equivalent properties;
  - 1.1.2 provided with an efficient non-slip surface either by longitudinal grooving or by the application of an approved non-slip coating;
  - 1.1.3 not less than 1370 millimetres long, 115 millimetres wide and 25 millimetres in depth, excluding any non-slip surface or coating; and
  - 1.1.4 equally spaced not less than 300 millimetres or more than 380 millimetres apart and secured in such a manner that they will remain horizontal.

- 1.2** The side and centre ropes of the three string embarkation ladder shall consist of two parts of uncoiled 20 millimetres diameter good quality manila ropes.
- 1.3** The steps for the two string embarkation ladder, applicable to Ships Other than Classes III to VI(A) Regulations, shall be:
- 1.3.1** made of hardwood, free from knots or other irregularities, smoothly machined and free from sharp edges and splinters, or of suitable material of equivalent properties;
  - 1.3.2** provided with an efficient non-slip surface either by longitudinal grooving or by the application of an approved non-slip coating;
  - 1.3.3** not less than 480 millimetres long, 115 millimetres wide and 25 millimetres in depth, excluding any non-slip surface or coating; and
  - 1.3.4** equally spaced not less than 300 millimetres or more than 380 millimetres apart and secured in such a manner that they will remain horizontal.
- 1.4** The side and centre ropes of the two string embarkation ladder shall consist of two parts of uncoiled 20 millimetres diameter good quality manila ropes.

## SCHEDULE 7

### PYROTECHNIC SIGNALS AND LINE-THROWING APPLIANCES

#### PART 1 – GENERAL

##### *General*

1. A pyrotechnic signal shall –

- 1.1 be constructed with proper workmanship and materials;
- 1.2 not be damaged in stowage in the air temperature range of  $-30^{\circ}\text{C}$  to  $+65^{\circ}\text{C}$ ;
- 1.3 be contained in a water-resistant casing;
- 1.4 have integral means of ignition which can be readily operated with wet, cold or gloved hands in adverse conditions and require the minimum of preparation;
- 1.5 in the case of a rocket parachute flare or a hand flare be so designed that, when used in accordance with the manufacturer's operating instructions, it shall not cause discomfort to the person holding the casing or endanger a liferaft by burning or glowing residues;
- 1.6 in the case of a buoyant smoke signal be so designed that it shall not ignite explosively when used in accordance with the manufacturer's operating instructions;
- 1.7 be so constructed that any sealing shall not depend on adhesive tapes, or plastic envelopes;
- 1.8 be so constructed that the end from which the rocket is ejected can be positively identified by day or night;
- 1.9 be so constructed that all components, compositions and ingredients of the signal and the means of igniting it shall be of such character and quality to enable the signal to maintain its serviceability under good average storage conditions in the marine environment for a period of at least 4 years; and
- 1.10 be so constructed that if it is intended to be stowed in a liferaft it can function effectively after being subjected to a drop test appropriate to the height at which the liferaft is to be stowed, when the signal is packed in the equipment container.

##### *Marking*

- 2.1 A pyrotechnic signal shall have printed on its casing brief instructions or diagrams clearly illustrating how it is to be used.
- 2.2 The date of manufacture and the date of expiry shall be marked indelibly on the casing.

## PART 2 – ROCKET PARACHUTE FLARES

### *General*

1. Every rocket parachute flare shall comply with the requirements of Part 1 and in addition shall comply with the requirements of this Part.

### *Performance*

2. A rocket shall, when fired vertically, reach an altitude of not less than 300 metres. At or near the top of its trajectory, the rocket shall eject a parachute flare, which shall –
  - 2.1 burn with a bright red colour;
  - 2.2 burn uniformly with an average luminous intensity of not less than 30,000 candela;
  - 2.3 have a burning period not less than 40 seconds;
  - 2.4 have a rate of descent of not more than 5 metres/second; and
  - 2.5 not damage its parachute or attachments while burning.
3. The rocket shall in addition be capable of functioning when the rocket is fired at an angle of 45 degrees to the horizontal.

Other Ships Regulations  
regs 23, 63, 64, 65, 66, 67, 68 and 69  
Schedule 2 Part 4  
Schedule 4 Part 2

## PART 3 – HAND FLARES

### *General*

1. Every flare shall comply with the requirements of Part 1 and in addition shall comply with the requirements of this Part.

### *Performance*

2. A hand flare shall –
  - 2.1 burn with a bright red colour;
  - 2.2 burn uniformly with an average luminous intensity of not less than 15,000 candela;
  - 2.3 have a burning period of not less than 1 minute; and
  - 2.4 after ignition continue to burn after having been immersed for a period of 10 seconds under 100 millimetres of water.

## PART 4 – BUOYANT SMOKE SIGNALS

### *General*

1. Every buoyant smoke signal shall comply with the requirements of Part 1 and in addition with the requirements of this Part.

### *Performance*

2. A buoyant smoke signal shall –
  - 2.1 emit smoke of a highly visible colour at a uniform rate for a period of not less than 3 minutes when floating in calm water;
  - 2.2 not emit any flame during the entire smoke emission time;
  - 2.3 not be swamped in a sea-way; and
  - 2.4 continue to emit smoke when submerged in water for a period of 10 seconds under 100 millimetres of water.
3. It shall be safe to operate in water covered by a low flash point liquid.

Small Passenger Ship Regulations  
regs 5 and 6

Other Ships Regulations  
regs 7, 8, 10, 11, 20, 21  
42, 43, 44, 45, 47, 48  
63, 64, 65, 66, 67, 68, and 69

## PART 5 – LINE-THROWING APPLIANCES

### *Construction*

1. A line-throwing appliance shall –
  - 1.1 be constructed with proper workmanship and materials;
  - 1.2 in the case of an integral rocket and line, be contained in a water-resistant casing; in the case of a pistol fired rocket, the rocket shall be contained in a water-resistant casing;
  - 1.3 include not less than four projectiles;
  - 1.4 include not less than four lines each having a breaking strength of not less than 20 kiloNewtons; and
  - 1.5 be so designed that the end from which the rocket is ejected can be positively identified by day or night.
2. Rockets, cartridges and igniters shall be so constructed that all components, compositions and ingredients shall be of such character and quality to maintain serviceability under good average storage conditions in the marine environment for a period of at least 4 years.
3. Rockets, cartridges and igniters shall be so constructed that any sealing shall not depend on adhesive tapes or plastic envelopes.

### *Performance*

- 4.1 A line-throwing appliance shall be capable of throwing a line not less than 4 millimetres in diameter a distance of at least 230 metres in calm weather.
- 4.2 A line-throwing appliance shall be capable of throwing a line in such a manner that the lateral deflection on either side of the direction of firing does not exceed 10 per cent of the length of flight of the rocket in calm weather.

### *Marking*

- 5.1 A line-throwing appliance shall be marked with brief instructions or diagrams clearly illustrating the use of the appliance.
- 5.2 The date of manufacture and the date of expiry shall be marked indelibly on the rockets, cartridges and igniters.

## **PART 6 – INFORMATION INSTRUCTIONS AND STOWAGE**

- 1. Instructions and information for pyrotechnic signals shall be in a form suitable for the training manual referred to in Schedule 14. Instructions and information shall be in English in a clear and concise form and shall include –
  - 1.1 a description of the item;
  - 1.2 the method of its use, including any precautions or warnings;
  - 1.3 its stowage;
  - 1.4 guidance on when it is to be used; and
  - 1.5 instructions for replacing rockets, cartridges or strikers (integral line-throwing appliance).

## SCHEDULE 8

### LIFEBUOYS AND ATTACHMENTS

#### PART 1 – GENERAL

##### *General*

1. Every lifebuoy and its attachments required by Regulation, shall comply with the requirements of Schedule 1 as are applicable to it.

##### *Instructions and information*

2. In the case of lifebuoy self-igniting lights or self-activating smoke signals, instructions and information shall be in a form suitable for the training manual and, if appropriate, the instructions for on-board maintenance referred to in Schedule 14. Instructions and information shall be in English in a clear and concise form and shall include –
  - 2.1 the stowage and attachments to the lifebuoy;
  - 2.2 the type of energy source if provided and, if replaceable, the method and frequency of its replacement;
  - 2.3 the type of light source if provided and whether it is replaceable;
  - 2.4 any maintenance requirements including the method and frequency of checking the of the energy source if one is provided; and
  - 2.5 the operation of the light or signal and its duration.

#### PART 2 – LIFEBUOYS (SOLAS)

##### *Construction*

- 1.1 A lifebuoy shall have an outer diameter of not more than 800 millimetres and an inner diameter of not less than 400 millimetres.
- 1.2 A lifebuoy shall be constructed of inherently buoyant material. It shall not depend for buoyancy upon rushes, cork shavings, granulated cork, any other loose granulated material or an air compartment.
- 1.3 It shall have a mass of not less than 2.5 kilogrammes: except that if it is to operate a quick release arrangement for a self-activating smoke signal and self-igniting light it shall have a mass sufficient to operate the arrangement or 4 kilogrammes, whichever is the greater.
- 1.4 It shall be constructed to withstand a drop into water from the height at which it is stowed above the waterline in the lightest seagoing conditions or 30 metres, whichever is the greater, without impairing either its operating capability or that of its attached components.

- 1.5 It shall be fitted with a grabline of not less than 9.5 millimetres in diameter and of length not less than 4 times the outside diameter of the lifebuoy. The grabline shall be secured at four equidistant points around the circumference of the lifebuoy to form four equal loops.

#### *Performance*

- 2.1 A lifebuoy shall be capable of supporting not less than 14.5 kilogrammes of iron in fresh water for period of 24 hours.
- 2.2 It shall not sustain burning or continue melting after being totally enveloped in a fire for a period of 2 seconds.

#### *Marking*

- 3.1 A lifebuoy shall be marked in block capitals with the name and the port of registry of the ship on which it is carried.
- 3.2 A lifebuoy shall be permanently marked with the maximum height above the waterline at which it can be stowed if this exceeds 30 metres.

**Other Ships Regulations**  
regs 46, 47, 68 and 69

### **PART 3 – LIFEBOUOYS (610 millimetres)**

1. Every lifebuoy (610 millimetres) shall comply with requirements of Part 1 and 2: except that in paragraph –
- 1.1 it shall have outer diameter of not less than 610 millimetres and an inner diameter of not less than 350 millimetres;
- 1.2 it shall have a mass of not less than 1.3 kilogrammes;
- 1.3 the lightest seagoing condition should be taken to be 10 metres; and
- 1.4 the grabline should not be less than 6 millimetres in diameter.

**Small Passenger Ship Regulations**  
regs 6, 7, and 9

**Other Ships Regulations**  
regs 42, 43, 44, 45, 46, 47, 48  
63, 64, 65, 66, 67, 68 and 69

### **PART 4 – LIFEBOUOY SELF-IGNITING LIGHTS**

#### *Construction*

- 1.1 It shall be constructed to withstand a drop into the water from the height at which it is stowed above the waterline in the lightest seagoing condition or 30 metres, whichever is the greater, without impairing either its operating capability or that of the lifebuoy to which it is attached.
- 1.2 It shall be provided with means for being efficiently attached to a lifebuoy.
- 1.3 A lifebuoy self-igniting light attached to a lifebuoy carried by tanker shall be of an electric battery type.
- 1.4 Components of electronic circuits should comply with the quality control requirements of BS 9000 or an equivalent standard. Where components cannot be obtained under one of the

above standards these components may be covered by a Certificate of Conformance from the manufacturer of the components.

### *Performance*

- 2.1 A lifebuoy self-igniting light shall be such that it cannot be extinguished by water.
- 2.2 It shall be capable of either burning continuously with a luminous intensity of not less than 2 candela in all directions of the upper hemisphere or flashing (discharge flashing) at a rate of not less than 50 flashes and not more than 70 flashes per minute with at least the corresponding effective luminous intensity and be provided with a source of energy which will give this performance for a period of at least 2 hours.
- 2.3 It shall be capable of withstanding the drop test required by Part 2 paragraph 1.4.

### *Marking*

3. A lifebuoy self-igniting light shall be marked indelibly with –
  - 3.1 the manufacturer's name or trade mark;
  - 3.2 clear and concise directions for use in English supported where necessary by illustrations;
  - 3.3 the type of energy source;
  - 3.4 the date of manufacture and expiry in the case of a light with a non-replaceable energy source; and
  - 3.5 the maximum height above waterline at which it can be stowed.

Small Passenger Ship Regulations  
regs 5, 6, 7, 8 and 9

Other Ships Regulations  
regs 24, 42, 43, 44, 45, 46, 47, 48  
63, 64, 65, 66, 67, 68, and 69

## **PART 5 – LIFEBOUY SELF-ACTIVATING SMOKE SIGNALS**

### *Construction*

- 1.1 It shall be constructed to withstand a drop into the water from the height at which it is stowed above the waterline in the lightest seagoing condition or 30 metres, whichever is the greater, without impairing either its operating capability or that of the lifebuoy to which it is attached.
- 1.2 It shall be provided with means for being efficiently attached to a lifebuoy.
- 1.3 A lifebuoy self-activating smoke signal may also be provided with a self-igniting light which shall comply with the requirements of Part 4.

### *Performance*

- 2.1 A lifebuoy self-activating smoke signal shall emit smoke of a highly visible colour at a uniform rate for a period of at least 15 minutes when floating in calm water.
- 2.2 It shall not ignite explosively or emit any flame during the entire smoke emission time of the signal.
- 2.3 It shall not be swamped in a sea-way.

- 2.4 It shall continue to emit smoke when fully submerged for a period of at least 10 seconds.
- 2.5 It shall be capable of quick release from its stowed position.
- 2.6 It shall be safe to operate in waters covered by a low flashpoint liquid.
- 2.7 All components, composition and ingredients of the lifebuoy self-activating smoke signal, and the energy source of the self-igniting light, if provided, shall be of such character and quality as to enable them to maintain their serviceability under good average stowage conditions in the marine environment for a period of at least four years unless, in the case of a self-igniting light energy source, it is possible to readily renew the energy source.

### *Marking*

- 3. A lifebuoy self-activating smoke signal shall be marked indelibly with –
  - 3.1 the manufacturer's name or trade mark;
  - 3.2 the lot number or other means of identifying the signal;
  - 3.3 clear and concise directions for use in English supported where necessary by illustrations;
  - 3.4 the date of manufacture and date of expiry;
  - 3.5 the type of energy source in the case of a signal provided with a self-activating light; and
  - 3.6 the maximum height above the waterline at which it can be stowed.

**Small Passenger Ship Regulations**  
regs 5, 6, 7, 8 and 9

**Other Ships Regulations**  
regs 42, 43, 44, 45, 46, 47, 48  
63, 64, 65, 66, 67, 68, and 69

## **PART 6 – LIFEBOUY BUOYANT LIFELINES**

### *Construction*

- 1.1 A lifebuoy buoyant lifeline shall be non-kinking.
- 1.2 It shall have a diameter of not less than 8 millimetres.
- 1.3 It shall have a breaking strength of not less than 5 kiloNewtons.
- 1.4 It shall be resistant to deterioration from exposure to sunlight.
- 1.5 It shall have a length not less than twice the height at which it is stowed above the waterline in the lightest seagoing condition, or 30 metres, whichever is the greater. On ships of less than 12 metres in length the lifeline shall be at least 18 metres in length.

## SCHEDULE 9

### LIFEJACKETS AND ATTACHMENTS

#### PART 1 – GENERAL

##### *General*

1. Every lifejacket and its attachment required by Regulations shall comply with the requirements of Schedule 1 as is applicable to it.

##### *Construction*

- 2.1 A lifejacket shall be so constructed that –
  - 2.1.1 at least 75 per cent of persons, who are completely unfamiliar with the lifejacket, can correctly don it within a period of one minute without assistance, guidance or prior demonstration;
  - 2.1.2 after a demonstration, all persons can correctly don it within a period of 1 minute without assistance;
  - 2.1.3 it is capable of being worn inside out or, if that is not the case, it is clear that it can be worn only in one way and, as far as is possible, it cannot be donned incorrectly;
  - 2.1.4 it is comfortable to wear; and
  - 2.1.5 it allows the wearer to jump from a height of at least 4.5 metres into the water without injury and without dislodging or damaging the lifejacket.
- 2.2 It shall be so constructed that the buoyancy is not reduced by more than 5 per cent after 24 hours submersion in fresh water.
- 2.3 It shall be fitted with a whistle firmly secured by a cord of suitable length. The whistle shall be non-metallic and not be affected by water or humidity.
- 2.4 It shall be fitted with retro-reflective material to assist detection, and the dimensions and location of the material shall be such as to meet this objective.
- 2.5 It shall be fitted with a ring or loop or similar device of adequate strength to facilitate rescue.
- 2.6 It shall be fitted with an approved light if it is intended for a ship which is required to carry lifejackets fitted with lights.

##### *Performance*

- 3.1 It shall have sufficient buoyancy and stability in calm fresh water to –
  - 3.1.1 lift the mouth of an exhausted or unconscious person not less than 120 millimetres clear of the water with the body inclined backwards at an angle of not less than 20 degrees and not more than 50 degrees from the vertical position; and

- 3.1.2 turn the body of an unconscious person in the water from any position to one where the mouth is clear of the water in not more than 5 seconds.
- 3.2 An inherently buoyant lifejacket shall allow the person wearing it to swim a short distance and to board a survival craft.
- 3.3 The buoyancy of the lifejacket shall not reduce by more than 5 per cent after 24 hours submersion in fresh water.
- 3.4 It shall not sustain burning or continue melting after being totally enveloped in a fire for a period of 2 seconds.

### *Marking*

- 4. A lifejacket shall be marked indelibly with –
  - 4.1 the manufacturer's name or trade mark and the name of the lifejacket, if any;
  - 4.2 the words "PERSON OF 32 KG OR MORE" in letters not less than 12 millimetres in size on the front in the case of inflatable lifejackets and on both sides in the case of lifejackets which can be worn inside out. In the case of lifejackets which can only be worn one way the marking shall be on the outside of the lifejacket;
  - 4.3 the year of manufacture or, in the case of an inflatable lifejacket, the means to identify the date of manufacture;
  - 4.4 the word "FRONT" on both sides of the front part of the lifejacket in letters not less than 12 millimetres in size in the case of lifejackets which can be worn inside-out. In the case of lifejackets which can only be worn one way the marking shall be on the outside of the front part of the lifejacket.

### *Lifejacket Lights*

#### *Construction*

- 5.1.1 The complete light unit shall be constructed with proper workmanship and materials. The materials shall be compatible with materials used in the construction of a lifejacket and with an immersion suit designed to be worn with a lifejacket.
- 5.1.2 The unit shall be rot-proof, corrosion-resistant and not be unduly affected by seawater, oil or fungal attack.
- 5.1.3 The unit shall not have any adverse effect on the performance of the lifejacket or immersion suit to which it is attached.
- 5.1.4 Each component of the unit shall be designed to remain serviceable for at least as long as the storage life of the power source.
- 5.1.5 The unit shall be so designed that it will not leak any substance which would be harmful to the lifejacket, immersion suit or wearer.
- 5.1.6 A flashing light shall be provided with a manually operated switch.
- 5.1.7 A flashing light shall not be fitted with a lens or curved reflector to concentrate the beam.
- 5.1.8 Components of electric circuits shall comply with the quality control requirements of

ISO 9000 or an equivalent standard. Where components cannot be obtained under one of the above standards these components shall be covered by a Certificate of Conformance from the manufacturer of the components.

#### *Attachment*

- 5.2.1 The method of attachment shall not require penetration of a lifejacket's buoyancy material or adversely affect the watertight integrity of an immersion suit.
- 5.2.2 The method of attachment shall be such that the light cannot become accidentally detached.
- 5.2.3 The light and power source shall be capable of being removed and replaced without causing damage to the lifejacket or immersion suit.

#### *Activation*

- 5.3 The light shall be easy to activate with wet, cold or gloved hands in adverse conditions with the minimum of preparation.

#### *Performance*

- 5.4.1 A lifejacket light shall not be damaged in stowage in an air temperature range of  $-30^{\circ}\text{C}$  to  $+65^{\circ}\text{C}$ .
- 5.4.2 It shall operate as prescribed in paragraphs 5.4.7 and 5.4.8 in a seawater temperature range of  $-1^{\circ}\text{C}$  to  $+30^{\circ}\text{C}$ . It shall also be capable of operating in fresh water.
- 5.4.3 It shall be capable of operation in a sea-way when attached to a lifejacket or immersion suit.
- 5.4.4 It shall be visible over as great a segment of the upper hemisphere as is practicable when attached to a lifejacket or immersion suit.
- 5.4.5 It shall be white in colour.
- 5.4.6 A flashing light shall flash at a rate of not less than 50 and not more than 70 flashes per minute and shall attain this rate within 5 minutes of activation.
- 5.4.7 A water activated light shall commence functioning within 2 minutes of immersion and have reached a luminous intensity of 0.75 candela within 5 minutes in salt water at temperatures of  $-1^{\circ}\text{C}$  and  $+30^{\circ}\text{C}$  and within 10 minutes in fresh water at ambient temperature.
- 5.4.8 A fixed light and a flashing light with a flash duration of not less than 50 flashes and not more than 70 flashes per minute shall have a luminous intensity of not less than 0.75 candela in all directions of the upper hemisphere.
- 5.4.9 A light shall have a source of energy capable of providing the luminous intensity, or effective luminous intensity, as appropriate, for a period of at least 8 hours.
- 5.4.10 The unit and the lifejacket or immersion suit attachment arrangements shall be capable of withstanding a jump into the water from a height of 4.5 metres without the unit being damaged or dislodged or causing injury to the wearer of the lifejacket or immersion suit.
- 5.4.11 The unit shall be capable of withstanding a drop of 2 metres onto a rigidly mounted steel plate or concrete surface.

## *Marking*

- 5.5.1 The unit shall be indelibly marked with –
- 5.5.1.1 the manufacturer's name or trade mark;
  - 5.5.1.2 the batch number or other means of identifying the unit; and
  - 5.5.1.3 clear and concise directions in English for activating the light supported by illustrations.
- 5.5.2 The unit or power source as appropriate, shall be marked indelibly with the date of manufacture and expiry of the power source.

## *Instructions and Information*

- 5.6.1 Instructions and information shall be in a form suitable for the training manual and, if appropriate, in the instructions for on-board maintenance referred to in Schedule 14. Instructions and information shall be in English in a clear and concise form and shall include –
- 5.6.1.1 the method or methods of attachment to lifejackets and immersion suits;
  - 5.6.1.2 the type of power source for the particular type of light;
  - 5.6.1.3 if the power source is replaceable, the method of replacement;
  - 5.6.1.4 the type of light source and whether replaceable;
  - 5.6.1.5 any maintenance requirements including the method and recommended frequency of checks of power source; and
  - 5.6.1.6 the operation of the light.

Small Passenger Ship Regulations  
regs 5, 6, 7, 8 and 9

Other Ships Regulations  
regs 42, 43, 44, 45, 46, 47, 48  
63, 64, 65, 66, 67, 68 and 69

## **PART 2 – INHERENTLY BUOYANT LIFEJACKETS (For persons weighing 32 kilogrammes or over)**

### *General*

1. Inherently buoyant lifejackets for persons weighing 32 kilogrammes or over shall comply with the requirements of Part 1 and the requirements in this Part.

### *Materials*

- 2.1 Buoyancy material shall be of good quality synthetic material, or kapok.
- 2.2 Cover material where used shall be of –
- 2.2.1 good quality synthetic material, or pre-shrunk cotton material free of admixture of sizing or other foreign matter; and
  - 2.2.2 a highly visible colour such as traffic yellow (BSEN 381, Ref 368) international orange (BSEN 381, Ref 592) or a colour of equivalent conspicuity.

- 2.3 Where a synthetic cover material is used and the seams are stitched, the thread shall be of synthetic material. Where cotton cover material is used the thread shall be of natural fibre or a combination of synthetic and natural fibre.
- 2.4 Fastening tapes shall not be less than 32 millimetres wide and have a breaking strength of not less than 1.4 kiloNewtons. Tapes of a synthetic material shall be capable of providing an equivalent degree of security when tied as that provided by cotton tapes.

*Instructions and Information*

3. Instructions and information shall be in a form suitable for the training manual referred to in Schedule 14. Instructions and information shall be in English in a clear and concise form and shall include how the lifejacket is to be donned and secured.

Small Passenger Ship Regulations  
regs 5, 6, 7, 8 and 9

Other Ships Regulations  
regs 42, 43, 44, 45, 46, 47, 48  
63, 64, 65, 66, 67, 68 and 69

**PART 3 – INHERENTLY BUOYANT LIFEJACKETS  
(For persons weighing less than 32 kilogrammes)**

*General*

1. Inherently buoyant lifejackets for persons weighing less than 32 kilogrammes shall comply with the requirements of Parts 1 and 2, except that –
- 1.1 donning assistance is permitted for small children;
- 1.2 it shall only be required to lift the mouth of an exhausted or unconscious wearer clear of the water a distance appropriate to the size of the intended wearer;
- 1.3 assistance may be given to board a survival craft, but wearer mobility shall not be significantly reduced; and
- 1.4 in addition to the markings required by paragraph 4.2 of Part 1 they shall be marked with a “child” symbol as shown in the “childs lifejacket” symbol in Section B of Schedule 16 and the height or weight range for which the lifejacket will meet the approval requirements.

Small Passenger Ship Regulations  
regs 5, 6, 7 8 and 9

Other Ships Regulations  
regs 42, 43, 44, 45, 46, 47, 48  
63, 64, 65, 66, 67, 68 and 69

**PART 4 – INFLATABLE LIFEJACKETS  
(for persons weighing 32 kilogrammes or over)**

*General*

1. Inflatable lifejackets for person weighing 32 kilogrammes or over shall comply with the requirements of Part 1 and the requirements in this Part.

*Construction*

- 2.1 An inflatable lifejacket shall be constructed with not less than two separate compartments and it shall inflate automatically on immersion. The automatic inflation system shall be so designed and protected that the risk of inadvertent inflation is reduced to a minimum. It shall be provided with a device to permit inflation by a single manual motion and shall be capable of being inflated by mouth.

- 2.2 In the event of loss of buoyancy in any one compartment the lifejacket shall be capable of complying with the requirements of paragraphs 2.1, 3.1 and 3.2 of Part 1.
- 2.3 The inflatable compartments shall be so located that when inflated they do not channel water into the wearer's face when in a sea-way.
- 2.4 An inflatable lifejacket shall comply with the requirements of paragraph 2.2 of Part 1 after inflation by means of the automatic mechanism.

#### ***Materials and Components***

- 3.1 Materials and components shall comply, as applicable, with the requirements of BS EN 394 and 396.
- 3.2 Materials used on the exterior of the buoyancy chambers shall be of a highly visible colour such as traffic yellow (BS EN 381, Ref 368), international orange (BS EN 381, Ref 592) or a colour of equivalent conspicuity.

#### ***Instructions and Information***

4. Instructions and information shall be in a suitable form for the training manual and, if appropriate, the instructions for on-board maintenance referred to in Schedule 14. Instructions and information shall be in English in a clear and concise form and shall include –
  - 4.1 a description of lifejacket and attachments;
  - 4.2 the method of donning;
  - 4.3 the method of operation;
  - 4.4 its packaging;
  - 4.5 any maintenance requirements;
  - 4.6 any servicing requirements;
  - 4.7 the type and charged weight of gas bottles; and
  - 4.8 the method of replacing gas bottles.

**Small Passenger Ships Regulations**  
regulations 7 and 8

#### **PART 5 – INFLATABLE CIVIL AVIATION AUTHORITY LIFEJACKET**

Inflatable lifejackets which are suitable for persons weighing 32 kilogrammes or more, or less than 32 kilogrammes, which have been approved by the United Kingdom Civil Aviation Authority comply with this Schedule if they have been fitted with a ring or loop or similar device, having a minimum breaking strain of 1.8 kiloNewtons to facilitate rescue: provided that an approved light is not required.

**Small Passenger Ships Regulations**  
regulation 7 and 8

#### **PART 6 – BUOYANCY AIDS**

Inherent buoyant lifejackets for persons weighing 32 kilogrammes or over, or under 32 kilogrammes shall comply with requirements of British Standard CEN 100 Standard and in addition shall be fitted with a ring or loop or similar device, having a minimum breaking strain of at least 1.8 kiloNewton to facilitate rescue.

## SCHEDULE 10

### REQUIREMENTS FOR IMMERSION SUITS, ANTI-EXPOSURE SUITS AND THERMAL PROTECTIVE AIDS

#### PART 1 – IMMERSION SUITS

##### *General*

1. Every lifejacket and its attachment required by Regulations shall comply with the requirements of Schedule 1 as is applicable to it.

##### *Construction*

- 1.1 An immersion suit shall be constructed with proper workmanship and waterproof materials.
- 1.2 The materials of the suit shall be rot-proof, corrosion resistant and not unduly affected by seawater, oil or fungal attack.
- 1.3 An immersion suit shall be of a highly visible colour to assist detection.
- 1.4 It shall be fitted with retro-reflective material to assist detection.
- 1.5 It shall be constructed to cover the whole body with the exception of the face. Hand covering shall be provided as an integral part of the suit or by means of permanently attached gloves.
- 1.6 It shall be provided with arrangements to minimise or reduce free air in the legs of the suit.
- 1.7 It shall be fitted with a non-metallic whistle not affected by water and humidity and firmly secured by a cord of suitable length, means of attaching a lifejacket light complying with Part 1 in Schedule 9 and, if the suit has buoyancy and is designed to be worn without a lifejacket, a ring or loop or similar device of adequate strength to facilitate rescue.
- 1.8 An immersion suit which also complies with the requirements of Parts 1 or 2 of Schedule 9 may be classified as a lifejacket.
- 1.9 An immersion suit shall be provided with a valise or container for stowage purposes.

##### *Performance*

- 2.1 An immersion suit shall not be damaged in stowage in the air temperature range of  $-30^{\circ}\text{C}$  to  $+65^{\circ}\text{C}$ .
- 2.2 It shall operate in a seawater temperature range of  $-1^{\circ}\text{C}$  to  $+30^{\circ}\text{C}$ .
- 2.3 It shall be resistant to deterioration where exposed to sunlight.
- 2.4 An immersion suit shall be capable of satisfactory operation in a sea-way.
- 2.5 An immersion suit shall permit the person wearing it (and a lifejacket if the immersion suit is to be worn in conjunction with a lifejacket) to –
  - 2.5.1 climb up and down a vertical ladder at least 5 metres in length;
  - 2.5.2 perform normal duties during abandonment;

- 2.5.3 jump from a height of not less than 4.5 metres into the water without damaging or dislodging the immersion suit, or being injured; and
- 2.5.4 swim a short distance through the water and board a survival craft.
- 2.6 The suit shall be capable of being unpacked and donned without assistance within 2 minutes, taking into account any associated clothing and a lifejacket if the immersion suit is to be worn in conjunction with a lifejacket.
- 2.7 It shall not sustain burning or continue melting after being totally enveloped in a fire for a period of 2 seconds.
- 2.8 Following a jump from a height of not less than 4.5 metres into water there shall be no undue ingress of water into the suit.
- 2.9 When the wearer is exposed to disturbed water conditions for a period of 20 minutes there shall be no undue ingress of water into the suit.
- 2.10 The person wearing it shall be able to don a lifejacket without assistance if the immersion suit is to be worn with a lifejacket over it.
- 2.11 If the material has no inherent insulation the suit when worn in conjunction with warm clothing (and a lifejacket if the immersion suit is to be worn with a lifejacket) the suit shall provide sufficient thermal protection to ensure that the wearer's body core temperature does not fall more than 2°C, –
  - 2.11.1 when it is worn for a period of 1 hour in calm circulating water at a temperature of 5°C taking into account any water ingress following a jump into the water from a height of 4.5 metres; and
  - 2.11.2 a 20 minute period in disturbed water conditions.
- 2.12 If the material has inherent insulation either on its own or when worn with a lifejacket (if the immersion suit is to be worn in conjunction with a lifejacket) the suit shall provide sufficient thermal insulation to ensure that the wearer's body core temperature does not fall more than 2°C, –
  - 2.12.1 after a period of 6 hours immersion in calm circulating water at a temperature of between 0°C and 2°C, taking into account any water ingress following a jump into the water from a height of 4.5 metres; and
  - 2.12.2 a 20 minute period in disturbed water conditions.
- 2.13 After being immersed in water at 5°C for a period of 1 hour the wearer of the immersion suit shall be able to pick up a pencil and write with hands covered.
- 2.14 A person in fresh water wearing an immersion suit which complies with the requirements of Parts 1 or 2 of Schedule 9 or an immersion suit with a lifejacket shall –
  - 2.14.1 be able to turn from a face-down to a face-up position in not more than 5 seconds;
  - 2.14.2 float in a stable face-up position with the mouth not less than 120 millimetres clear of the water.

### *Marking*

3. An immersion suit and the valise or container in which it is stowed shall be marked indelibly with the –
  - 3.1 manufacturer's name or trade mark;
  - 3.2 date of manufacture;
  - 3.3 size range for which it is designed;
  - 3.4 serial number; and
  - 3.5 instruction that it must be worn in conjunction with warm clothing if the suit is made of material which has no inherent insulation.

### *Instructions and information*

4. Instructions and information shall be in a suitable form for the training manual referred to in Part 1 of Schedule 14 and, if appropriate, for on-board maintenance referred to in Part 2 of that Schedule. Instructions and information shall be in English in a clear and concise form and shall include –
  - 4.1 a description of the immersion suit and attachments;
  - 4.2 on donning;
  - 4.3 on the operation of any auxiliary buoyancy;
  - 4.4 on the method of stowage;
  - 4.5 on any servicing and maintenance requirements;
  - 4.6 on cleaning; and
  - 4.7 its use.

## **PART 2 – ANTI-EXPOSURE SUITS**

### *Construction*

- 1.1 The anti-exposure suit shall comply with the requirements of Part 1 paragraphs 1, 2, 3 and 4 as applicable and with the requirements of this Part.
- 1.2 The anti-exposure suit shall be constructed with waterproof materials such that it –
  - 1.2.1 provides inherent buoyancy of at least 70 Newtons;
  - 1.2.2 is made of material which reduces the risk of heat stress during rescue and evacuation operations;
  - 1.2.3 covers the whole body with the exception of the head and hands; gloves and a hood shall be provided in such a manner as to remain available for use with the anti-exposure suits;
  - 1.2.4 can be unpacked and donned without assistance within 2 minutes;
  - 1.2.5 does not sustain burning or continue melting after being totally enveloped in a fire for a period of 2 seconds;

- 1.2.6 is equipped with a pocket for a portable VHF telephone; and
  - 1.2.7 has a lateral field of vision of at least 120 degrees.
- 2.1 An anti-exposure suit which also complies with the requirements of Part 1 and 2, Schedule 9 may be classified as a lifejacket.
- 2.2 An anti-exposure suit shall permit the person wearing it, to –
- 2.2.1 climb up and down a vertical ladder of at least 5 metres in length;
  - 2.2.2 jump from a height of not less than 4.5 metres into the water with feet first, without damaging or dislodging the suit, or being injured;
  - 2.2.3 swim through the water at least 25 metres and board a survival craft;
  - 2.2.4 don a lifejacket without assistance; and
  - 2.2.5 perform all duties associated with abandonment, assist others and operate a rescue boat.
- 2.3 An anti-exposure suit shall be fitted with a lifejacket light and a whistle.
- 2.4 An anti-exposure suit shall –
- 2.4.1 if made of material which has no inherent insulation, be marked with instructions that it must be worn in conjunction with warm clothing; and
  - 2.4.2 be so constructed, that when worn as marked, the suit continues to provide sufficient thermal protection following one jump into the water which totally submerges the wearer and shall ensure that when it is worn in calm circulating water at a temperature of 5 degrees C, the wearer's body core temperature does not fall at a rate of more than 1.5 degrees C per hour, after the first 30 minutes.
- 2.5 A person in fresh water wearing an anti-exposure suit shall be able to turn from a face-down to a face-up position in not more than 5 seconds and shall be stable face-up. The suit shall have no tendency to turn the wearer face-down in moderate sea conditions.

Other Ships Regulations  
regs 7, 8, 10, 11, 63, 64, 65, 66, 68 and 69  
Parts 2, 7 and 8 Schedule 2  
Parts 2 and 3 of Schedule 3  
Part 6 of Schedule 4

### PART 3 – THERMAL PROTECTIVE AIDS

#### *Construction*

- 1.1 A thermal protective aid shall be constructed with proper workmanship and materials.
- 1.2 The materials of a thermal protective aid shall be rot-proof, corrosion resistant, and not unduly affected by seawater, oil or fungal attack.
- 1.3 A thermal protective aid shall be made of waterproof material having a thermal conductivity of not more than  $7800W/(m^2K)$  and shall be so constructed that, it will reduce both the convective and evaporative heat loss from the wearer's body.

- 1.4 It shall be so constructed as to cover the whole body of a person wearing a lifejacket with the exception of the face. Hands shall also be covered unless permanently attached gloves are provided.
- 1.5 It shall be of a highly visible colour to assist detection.
- 1.6 It shall be protected by waterproof packaging which can be opened with wet or cold hands.

#### *Performance*

- 2.1 A thermal protective aid shall not be damaged in stowage in the air temperature range  $-30^{\circ}\text{C}$  to  $+65^{\circ}\text{C}$ .
- 2.2 It shall function properly in the air temperature range  $-30^{\circ}\text{C}$  to  $+20^{\circ}\text{C}$
- 2.3 It shall function in the seawater temperature range  $-1^{\circ}\text{C}$  to  $+30^{\circ}\text{C}$  if designed to be worn in a sea-way.
- 2.4 It shall be capable of being unpacked and easily donned without assistance in a survival craft or rescue boat.
- 2.5 It shall permit the wearer to remove it in the water in not more than 2 minutes, if it impairs ability to swim.

#### *Marking*

3. The thermal protective aid packaging shall be marked with –
  - 3.1 the manufacturer's name or trade mark; and
  - 3.2 instructions for use.

#### *Instructions and Information*

4. Instructions and information shall be in a form suitable for the training manual referred to in Part 1 of Schedule 14. Instructions and information shall be in English in a clear and concise form and include –
  - 4.1 stowage in lifeboats and liferafts;
  - 4.2 unpacking;
  - 4.3 donning in a survival craft;
  - 4.4 its removal from the wearer in the water (if applicable);
  - 4.5 its purpose, and when it should be used;
  - 4.6 whether or not ability to swim is impaired when wearing the aid; and
  - 4.7 on how it is to be checked and inspected.

## SCHEDULE 11

### GENERAL EMERGENCY ALARM SYSTEMS AND PUBLIC ADDRESS SYSTEMS

#### PART 1 – GENERAL EMERGENCY ALARM SYSTEMS

1. The general emergency alarm system shall be capable of sounding the general emergency alarm signal consisting of seven or more short blasts followed by one long blast on the ship's whistle or siren and additionally, in the case of ships of Classes I, II and II(A), and of Classes VII, VII(T), VIII, VIII(T) and IX of 45.7 metres in length or above on an electrically operated bell or klaxon or other equivalent warning system. This additional system shall be powered from the ship's main supply and from the emergency source of electrical power required by the Merchant Shipping (Passenger Ship Construction) Regulations 1996 or the Merchant Shipping (Cargo Ship Construction) Regulations 1996 as applicable.
2. The system shall be capable of operation from the navigating bridge and, except for the ship's whistle, also from other strategic points. The system shall be audible throughout all the accommodation and normal crew working spaces.
3. The system shall also be audible on all open decks and its sound level shall comply with paragraphs 5 and 6. The alarm shall continue to sound until it is manually turned off or is temporarily interrupted by a message on the public address system.
4. Entertainment systems shall be turned off automatically when the general emergency alarm system is activated.
5. The minimum sound pressure levels for the emergency alarm tone in interior and exterior spaces shall be 80 dB (A) and at least 10 dB (A) above ambient noise levels existing during normal equipment operation with the ship underway in moderate weather. In cabins without a loudspeaker installation, an electronic alarm transducer shall be installed, e.g. a buzzer or similar.
6. The sound pressure levels at the sleeping position in cabins and in cabin bathrooms shall be at least 75 dB (A) and at least 10 dB (A) above ambient noise levels.

Other Ships Regulations  
regs 7, 8 and 9

#### PART 2 – PUBLIC ADDRESS SYSTEMS

1. The public address system shall be one complete system consisting of a loudspeaker installation which enables simultaneous broadcast of messages from the navigation bridge, and at least one other location on board for use when the navigation bridge has been rendered unavailable due to the emergency, to all spaces where crew members or passengers, or both are normally present and to assembly stations (i.e. muster stations). The controls of the system on the navigation bridge shall be capable of interrupting any broadcast on the system from any other location on board. It shall not require any action by the addressee. It shall also be possible to address crew accommodation and work spaces separately from passenger spaces.
2. In addition to any function provided for routine use aboard the ship, the system shall have an emergency function control at each control station which –
  - 2.1 is clearly indicated as the emergency function;
  - 2.2 is protected against unauthorized use;

- 2.3 automatically overrides any other input system or programme; and
  - 2.4 automatically overrides all volume controls and on/off controls so that the required volume for the emergency mode is achieved in all spaces.
3. The system shall be installed with regard to acoustically marginal conditions, so that emergency announcements are clearly audible above ambient noise in all spaces. With the ship underway in normal conditions, the minimum sound pressure levels for broadcasting emergency announcements shall be –
- 3.1 in interior spaces 75 dB (A) and at least 20 dB(A) above the speech interference level; and
  - 3.2 in exterior spaces 80 dB (A) and at least 15 dB (A) above the speech interference level.
4. The system shall be arranged to prevent feedback or other interference.
5. The system shall be arranged to minimize the effect of a single failure, e.g. by the use of multiple amplifiers with segregated cable routes to public rooms, alleyways, stairways, and control stations. The public address systems shall have at least two loops of fire resistant cable which shall be sufficiently separated throughout their length and have two separate and independent amplifiers.
6. Each loudspeaker shall be individually protected against short circuits.
7. The public address system shall be arranged to operate on both the main source of electrical power and the emergency source of electrical power.

## SCHEDULE 12

### BUOYANT APPARATUS

#### *General*

1. Buoyant apparatus shall –
  - 1.1 be constructed with proper workmanship and materials;
  - 1.2 retain the shape and properties when exposed to the weather on board ship and when in the water. They shall be constructed so as not to require adjustment prior to use; and
  - 1.3 be corrosion-resistant and not affected by sea water, oil or oil products.

#### *Construction*

- 2.1 Buoyant apparatus shall be capable of withstanding a minimum drop into the water from a height of 10 metres. If they are to be stowed in a vessel at a height of more than 10 metres above the waterline in the lightest seagoing condition, they shall be of a type which has been satisfactorily drop-tested from at least that height.
- 2.2 Buoyant apparatus shall be effective and stable when floating either way up. They shall be capable of supporting a weight of iron, suspended in fresh water from the grab lines, of 22.5 kilogrammes per metre of length along any edge (subject to a minimum of 29 kilogrammes), without immersing any part of their upper surfaces.
- 2.3 The air cases or other equivalent provision for buoyancy shall be placed as near as possible to the sides of the apparatus. Buoyancy is not to be dependant upon inflation and any material providing buoyancy shall not be adversely affected by oil or oil products.
- 2.4 A buoyant apparatus shall not exceed 185 kilogrammes in weight unless suitable means are provided to enable it to be launched without lifting by hand. If the weight of the apparatus exceeds 135 kilogrammes suitable handles or rungs are to be fitted for lifting by hand.
- 2.5 The number of persons which a buoyant apparatus shall be considered capable of supporting shall be equal to the lesser of –
  - 2.5.1 the greatest whole number obtained by dividing by 14.5 the number of kilogrammes of iron which the apparatus is capable of supporting from its grab lines in fresh water; or
  - 2.5.2 the greatest whole number obtained by dividing the perimeter in metres by 0.3.

#### *Fittings*

- 3.1 Grab Lines
  - 3.1.1 Buoyant grablines shall be securely fitted all around the apparatus so as to provide an equal number of loops, the total number corresponding to the number of persons the apparatus is capable of supporting.
  - 3.1.2 Each loop shall have a depth of not less than 150 millimetres and not more than 200 millimetres. On apparatus exceeding 300 millimetres in overall depth two rows of grablines shall be fitted, one having its points of attachment below the top of the air

cases and the other above the bottom of the air cases and as close to the sides of the air cases as practical. On apparatus of 300 millimetres or less in overall depth, one row of grab lines is to be attached along the line at mid-depth.

**3.1.3** Grab lines shall be of buoyant rope of not less than 14 millimetres in diameter. The ropes may be passed through holes in the framing, interlaced to prevent movement; or attached by means of wrought iron or steel fastenings. Whichever method is used the attachment is to be of sufficient strength to permit the apparatus to be lifted by the grab lines.

**3.2** Each buoyant apparatus shall be fitted with an efficient painter of length at least equal to the height from its stowed position to the lightest sea going condition plus 5 metres.

**3.3** Retro-reflective material is to be fitted on all surfaces of the buoyant apparatus.

### *Marking*

**4.** Each apparatus shall be marked with the –

**4.1** maker's name or trademark;

**4.2** serial number; and

**4.3** maximum permitted height of stowage above waterline.

**SCHEDULE 13****SURVIVAL CRAFT EQUIPMENT AND RATIONS****PART 1 – FIRST AID OUTFITS**

- 1.1** The first aid outfit provided in every lifeboat, rescue boat, inflated boat or liferaft shall comply with the following requirements –
- 1.1.1** it shall be packed in a durable, damp-proof and effectively sealed container, capable of being closed tightly after use;
- 1.1.2** the container shall be protected; until opened for use, with an outer waterproof seal;
- 1.1.3** the container shall bear on its outside an itemised list of its contents, and their date of expiry;
- 1.1.4** it must comply with the implemented UK requirements of Council Directive 92/29/EEC which sets out minimum standards for ships' medical stores by introducing the Merchant Shipping and Fishing Vessel (Medical Stores) Regulations 1995, as amended by the Merchant Shipping and Fishing Vessel (Medical Stores) Amendment Regulations 1996. Merchant Shipping Notice MSN 1707 (M+F) lists the requirements for Category C vessels which lifeboats and life-rafts are required to carry and is shown in Table 1; and
- 1.1.5** drug supplies should be replenished wherever possible at the same strengths as specified in the British Pharmacopoeia. If drugs are obtained elsewhere, e.g in the USA, they may be of different strength, and this must be taken into account when administering them.

**TABLE 1****CATEGORY C  
MEDICAL SUPPLIES**

The numbering refers to the number allocated to the medicine or equipment in the Directive

<b>Ref no</b>	<b>Statutory Treatment Requirements</b>	<b>Recommended Medicine and Dosage Strength representing best practice</b>	<b>Recommended Quality for 10 workers or for a lifeboat or liferaft</b>
1	<b>Cardio vascular</b>		
(b)	Anti-angina preparations	Glyceryl Trinitrate Spray 400 micrograms/metered 200 dose aerosol or transdermal patches 5mg x 2	1 unit
(d)	Anti-haemorrhagics (including uterotonics if there are women with potential for child bearing working on board)	i) Phytomenadione (Vitamin K1) 10mg in 1ml ampoule	1

Ref no	Statutory Treatment Requirements	Recommended Medicine and Dosage Strength representing best practice	Recommended Quality for 10 workers or for a lifeboat or liferaft
		ii) Ergometrine Maleate 500mg inj. Oxytocin 5 units in 1ml ampoule	1
2	<b>Gastro intestinal system</b>		
(b)	Anti-emetics	Hyoscine hydrobromide 0.3mg tabs.	60
(d)	Anti-diarrhoeals	Codeine Phosphate 30mg tablets	20
3	<b>Analgesics and Anti-spasmodics</b>		
(a)	Analgesics	i) Paracetamol ii) Use 2(d)	50 Use 2(d)
4	<b>Nervous system</b>		
(c)	Seasickness remedies	Use 2(d)	Use 2(d)
9	<b>Medicines for External Use</b>		
(a)	Skin medicine		
	- Antiseptic solutions	100ml solution or pre-impregnated wipes containing 0.015% w/v chlorhexidine and 0.15% w/v cetrimide	1 bottle or 1 pack wipes
	- Burn preparations	Cetrimide Cream 50g tube	1

#### MEDICAL EQUIPMENT

Ref	Statutory Treatment Requirements	Recommended Specification	Quantity
1	<b>Resuscitation Equipment</b>		
	Mask for mouth to-mouth resuscitation	Laerdal Pocket Mask (or similar)	1
2	<b>Dressing and suturing equipment</b>		
	Adhesive elastic bandage	Adhesive Elastic Bandage 7.5cm x 4m	1
	Disposable polythylene gloves	large size	5prs
	Adhesive dressings	assorted, sterile	20
	Sterile compression bandages	(1) No. 13 Standard dressings (1) No. 14 Standard dressings (1) No. 15 Standard dressings	6 2 2
	Adhesive sutures or zinc oxide bandages	75mm adhesive suture strips	6
	Sterile Gauze Compresses	Packet containing 5 sterile gauze pads size 7.5cms x 7.5cms	1

Ref	Statutory Treatment Requirements	Recommended Specification	Quantity
		<b>Recommended Additional Item</b>	
		Scissors stainless steel/ or sterile disposable size	1 pr
		Calico triangular bandages about 90cm x 127cm	4
		medium safety pins, rustless	6
		sterile paraffin gauze dressings	10
		plastics burn bags	1

Schedule 2 Part 2

Schedule 4 Part 6

## PART 2 – FOOD RATIONS

1. The ration for each one or two persons shall be enclosed in substantial packaging of suitable efficiently sealed oxygen impermeable and moisture-proof materials. A ration intended for a lifeboat shall additionally be protected by durable water-resistant packaging.
2. The outer packaging or wrapping shall be marked with the manufacturer's name or trade mark, the weight, calorific value and description of the contents and the dates of manufacture and renewal. A description of the contents shall be marked on the inner packaging. It shall be possible to open the wrapping and packaging with wet or cold hands.
3. Recommended quantities of ration and fresh water to be consumed daily shall be marked in English on the packaging or on a water resistant instruction sheet included in the ration.
4. The ration for each person shall have a calorific value of not less than 10,000 kilojoules.
5. The composition of the ration –
  - 5.1 shall include at least 300 grammes of carbohydrate in the form of bland barley sugar sweets, glucose tablets or as part of a food tablet. The ration shall not include protein at a greater rate than 3 grammes per 10 grammes of carbohydrate or fat at a greater rate than 4 grammes per 10 grammes of carbohydrate; and
  - 5.2 shall have a salt content as low as possible which must not exceed 1 gramme NaCl. If the ration includes an approved anti-oxidant it shall be included at the rate of 0.02 per cent by weight of the fat component of the ration.
6. The moisture content of any barley sugar or food tablets in the ration shall not exceed 3 per cent and 7 per cent by weight respectively. The moisture content of a glucose tablet shall be as low as possible and compatible with the recommended operational shelf-life.
7. The ration shall be palatable to a survivor limited to a fresh water intake of 0.5 litres per day.
8. The ration shall remain palatable throughout its recommended shelf-life under the climatic conditions normally encountered.
9. The ration shall be readily divisible into at least 3 one-day portions for one person.

## PART 3 – FRESH WATER

### *General*

- 1.1 The water shall comply with the UK Laboratory of the Government Chemist test requirements or the equivalent standards of another State of the European Union to confirm that the water is microbiologically and chemically suitable for drinking and conforms to World Health Organisation standards.
- 1.2 Processing, packaging and sterilisation arrangements shall be carried out under hygienic conditions and quality assurance inspection acceptable to the Maritime and Coastguard Agency or the equivalent authority of another member State of the European Union.
- 1.3 The water shall remain palatable in its storage containers in the survival craft in a temperature range of  $-30^{\circ}\text{C}$  to  $+65^{\circ}\text{C}$ .

### *Water Containers*

#### *Sachets*

- 2.1.1 The water shall be packed in efficiently sealed sachets which are impermeable, moisture proof and have an effective vapour barrier.
- 2.1.2 The sachets shall have a cut above the top seal to facilitate easy opening with wet or cold hands.
- 2.1.3 Individual sachets shall contain not less than 50 and not more than 150 millilitres of water.
- 2.1.4 Water filled sachets shall be capable of withstanding a compressive load test of 5 kiloNewtons without bursting.
- 2.1.5 Except as provided for in paragraph 2.1.6 water sachets packed in a liferaft emergency pack shall not be affected by any of the prototype tests carried out on a liferaft.
- 2.1.6 When included in the emergency pack of an operationally packed liferaft no more than 2 per cent of the water sachets shall be damaged after the appropriate drop test.
- 2.1.7 The recommended shelf life of the water sachets shall be at least 3 years.
- 2.1.8 The outer packaging shall be marked with the following information the –
  - 2.1.8.1 manufacturer's name or trade mark;
  - 2.1.8.2 contents capacity;
  - 2.1.8.3 lot number;
  - 2.1.8.4 date of manufacture; and
  - 2.1.8.5 a recommended daily consumption per person.

## *Cans*

- 2.2.1 Cans in which drinking water is supplied shall be hermetically sealed with a vacuum of not less than 510 millimetres of mercury.
- 2.2.2 They shall be constructed of tinplate with minimum thickness 0.30 millimetres and a tin content conforming to the relevant part of section 10 of British Standard 113.
- 2.2.3 The cans shall be constructed with a double seam and properly balanced interlocking hooks. They shall be left plain internally but coated externally with a machine applied golden lacquer and then stoved.
- 2.2.4 The capacity of the can shall not be greater than 500 millilitres.
- 2.2.5 After filling the seams shall be inspected and any exposed areas shall be suitably lacquered.
- 2.2.6 A click test to confirm the vacuum shall be carried out on each can 7 days after filling.
- 2.2.7 The cans shall be free from dents or any signs of corrosion.
- 2.2.8 The cans shall not be affected by any of the prototype tests carried out on a liferaft.
- 2.2.9 The cans shall be clearly marked on the outside with the –
  - 2.2.9.1 manufacturer's name or trade mark;
  - 2.2.9.2 words "drinking water" and the capacity of the can in millilitres;
  - 2.2.9.3 lot or batch number;
  - 2.2.9.4 date of manufacture; and
  - 2.2.9.5 a recommended daily consumption per person.

## *Bottles*

- 2.3.1 Bottles in which drinking water is supplied shall be manufactured from a material which will not contaminate or effect the taste of the water.
- 2.3.2 They shall not be affected by any of the prototype tests carried out on a liferaft.
- 2.3.3 The material from which the bottle is made shall be opaque.
- 2.3.4 The capacity of the bottle shall not be greater than 500 millilitres.
- 2.3.5 The bottle shall be capable of being opened by a survivor with cold hands.
- 2.3.6 The minimum recommended shelf life of the water bottle and its contents shall be at least 3 years.
- 2.3.7 The bottle filling cap shall be fitted with a watertight seal, and have positive locking arrangements which will not be loosened by vibration. After the bottle has been filled and the cap fitted it shall be provided with an outer continuous seal which must not be broken until the water is used or has become time expired.

- 2.3.8 The bottle shall be marked on the outside with the –
- 2.3.8.1 manufacturer's name or trade mark;
  - 2.3.8.2 date of filling;
  - 2.3.8.3 date of expiry;
  - 2.3.8.4 words "drinking water" and the capacity of the bottle in millilitres;
  - 2.3.8.5 recommended daily consumption per person; and
  - 2.3.8.6 lot or batch number.

*Water tanks*

- 2.4.1 Tanks fitted for fresh water in a survival craft may be of metal or a plastic material acceptable to the Maritime and Coastguard Agency or the equivalent competent authority or of another member State of the European Union.
- 2.4.2 Each tank is to be filled and emptied to ensure cleanliness and to check for watertightness.
- 2.4.3 The tank shall be strong enough to withstand a head of water of at least 1.5 metres.
- 2.4.4 Where necessary the inside of the tank shall be suitably coated to prevent contamination or unpleasant taste.
- 2.4.5 Tanks which are not portable shall be fitted with drain plugs constructed of non-corrosive material.
- 2.4.6 Filling plugs and aperture covers shall be of non-ferrous materials, neatly fitted and made properly watertight to prevent the entry of contaminants.
- 2.4.7 Tanks shall be sited well clear of any propelling machinery.
- 2.4.8 At least one rustproof dipper with a lanyard shall be provided for each tank.
- 2.4.9 The inside of tanks constructed with glass reinforced plastic must be smooth and sealed with a gel coat.
- 2.4.10 Tanks made out of glass reinforced plastic shall be opaque.
- 2.4.11 The tank shall be clearly marked on the outside with the contents and its capacity in litres.

## PART 4 – SEA ANCHORS

1. A sea anchor shall be conical in shape and have the following dimensions –

CRAFT	SEA ANCHOR		Minimum Sloping Length of shroud Lines (mm)
	Minimum Mouth Diameter (mm)	Minimum Sloping Length (mm)	
Liferafts up to 10 person capacity	400	600	600
Liferafts 11 person capacity up to 25 person capacity and inflated boats	500	670	670
Liferafts over 25 person capacity, lifeboats and rescue boats up to 6 m in length	600	780	780
Lifeboats and rescue boats over 6 m in length and up to 9 m in length	700	920	920
Lifeboats over 9 m in length	800	1050	1050

2. The sea anchor material shall be porous, slightly stiff and shall allow a water penetration of between 10 and 12 cubic centimetres per second per square centimetre at a pressure of 550Pa (roughly equivalent to a speed through water of 2 knots).
3. The painter line used to secure the sea anchor to a liferaft or boat shall –
- 3.1 be inherently rot proof and of braided construction; and
  - 3.2 be 30 metres long; not less than 8 mm. in diameter and have a breaking load including attachments and knots of not less than –
    - 3.2.1 7.5 kN for liferafts up to 10 person capacity;
    - 3.2.2 10.0 kN for liferafts of 11 person to 25 person capacity; and
    - 3.2.3 10.0 kN for all other sea anchors or have a factor of safety of 3:1 based on a tow test at 6 knots whichever is the greater.
4. The shroud lines shall be designed to restrict the sea anchor from tumbling through itself.
5. The sea anchor shall be stable when towed through the water at speeds up to 6 knots.
6. The sea anchor mouth shall open immediately on deployment.

## SCHEDULE 14

### TRAINING MANUALS AND INSTRUCTIONS FOR ON-BOARD MAINTENANCE

#### PART 1 – TRAINING MANUALS

1. Training manuals shall contain instructions and information on the life-saving appliances provided in the ship. It shall also contain information on the best methods of survival. The material in the manual shall be in easily understood terms and illustrated where appropriate.
2. Training manuals may comprise one or more volumes and information may be provided in the form of audio-visual aids as an alternative to printed material.
3. Depending on the life-saving appliances provided in the ship, the following shall be explained in detail –
  - 3.1 donning of lifejackets, immersion suits and anti-exposure suits, as appropriate;
  - 3.2 muster at the assigned stations;
  - 3.3 boarding, launching, and clearing the survival craft, rescue boats, fast rescue boats, free-fall boats and inflated boats;
  - 3.4 method of launching from within the survival craft;
  - 3.5 release from launching appliances;
  - 3.6 methods and use of devices for protection in launching areas;
  - 3.7 illumination in launching areas;
  - 3.8 use of all survival equipment;
  - 3.9 use of all detection equipment;
  - 3.10 with the assistance of illustrations, the use of radio life-saving appliances;
  - 3.11 use of sea anchors;
  - 3.12 use of engine and accessories;
  - 3.13 recovery of the survival craft, rescue boats, fast rescue boats, free-fall boats and inflated boats including stowage and securing;
  - 3.14 hazards of exposure and the need for warm clothing;
  - 3.15 best use of the survival craft facilities in order to survive;
  - 3.16 methods of retrieval, including the use of helicopter rescue gear (slings, baskets, stretchers), breeches-buoy and shore life-saving apparatus and ship's line-throwing apparatus;
  - 3.17 all other functions contained in the muster list and emergency instructions;

- 3.18 instructions for emergency repair of the life-saving appliances;
- 3.19 means of rescue arrangements;
- 3.20 marine evacuation systems; and
- 3.21 helicopter landing and pick-up area operations.

**Other Ships Regulations**  
regs 36 and 84

## **PART 2 – INSTRUCTIONS FOR ON-BOARD MAINTENANCE**

- 1. Instructions for on-board maintenance of life-saving appliances shall be in easily understood terms and illustrated wherever possible.
- 2. The instructions shall include, where appropriate, the following for each appliance –
  - 2.1 a checklist for use when carrying out the inspections required by the Regulations;
  - 2.2 maintenance and repair instructions;
  - 2.3 a schedule of periodic maintenance;
  - 2.4 a diagram of lubrication points with the recommended lubricants;
  - 2.5 a list of replaceable parts;
  - 2.6 a list of sources of spare parts; and
  - 2.7 a record of inspection and maintenance.

## SCHEDULE 15

### CARRIAGE OF TWO-WAY VHF RADIOTELEPHONE SETS – EXEMPTING CONDITIONS

1. The conditions referred to in regulation 7(5)(b), 8(11)(b), 10(12)(b), 11(5)(b), 20(8)(b), 42(6)(b), 43(8)(b), 44(9)(b), 45(11)(b) and 47(3)(b) of the Other Ships Regulations under which ships may be exempted from the carriage of two-way VHF radiotelephone sets complying with performance standards contained in IMO Resolution A762(18) are given below.
  - 1.1 In the case of a passenger ship or a cargo ship of 500 tons or over, at least three and in the case of a cargo ship under 500 tons, at least two portable or VHF radiotelephone sets for use in survival craft shall be provided.
  - 1.2 The radiotelephone sets shall –
    - 1.2.1 be waterproofed;
    - 1.2.2 be capable of operating on radio frequency 156.8 MHz (VHF channel 16) and on at least one other channel;
    - 1.2.3 have the selection of 156.8 MHz (VHF Channel 16) correctly and clearly marked on the channel selector switch;
    - 1.2.4 in respect of United Kingdom ships, be of a type approved by the Department of Trade and Industry; or the equivalent competent authority of another member State of the European Union;
    - 1.2.5 have been provided on board ship prior to **1st February 1992**; and
    - 1.2.6 if replacement of a radio telephone becomes necessary, be replaced with approved equipment complying with IMO performance standards.
  - 1.3 Where secondary batteries are used in the radiotelephone sets, suitable arrangements shall be made to ensure the availability of fully charged sets at all times.

## SCHEDULE 16

### SYMBOLS RELATING TO LIFE-SAVING APPLIANCES AND ARRANGEMENTS

1. The Merchant Shipping (Life-Saving Appliances) Regulations 1999 require ships (other than fishing vessels) carrying survival craft to be provided with posters or signs on or in the vicinity of these craft and their launching controls. The posters and signs are to illustrate the purposes of the controls and the procedures for operating the appliance and to give relevant instructions or warnings. They must be capable of being seen under emergency lighting conditions where that is provided.
2. The symbols have been approved by the Maritime Safety Committee of the International Maritime Organization and the symbols used in the posters and signs referred to in paragraph 1 above must conform to the design and colour (white on a blue background) prescribed in Section A. The size of the symbol must be appropriate to the particular purpose for which it is being used; but where the diameter of the symbol is 60 millimetres or greater, it should be one of the preferred dimensions given in Amendment No. 1 to BS 5378 (a):Part 2: 1980.
3. The symbols are suitable for use on posters and signs at survival craft locations and for display inside survival craft adjacent to the relevant control or function to which they refer. Most of the symbols relate to totally enclosed lifeboats but there are some which can be used for conventional open lifeboats and davit-launched liferafts. In addition, symbols in the appropriate sequence can be displayed at the coxswain's position in a totally enclosed lifeboat as a reminder of the sequence of actions required to launch the lifeboat.
4. An additional set of symbols has also been approved by the Maritime Safety Committee and they appear in Section B. These symbols are intended to indicate the location of emergency equipment, and muster and embarkation stations. These symbols are not called for by the Regulations but many of them can be used with advantage on passenger ships. In particular, the symbol for a muster station (number 21) and the symbol indicating the direction to a muster/assembly station (number 23) could be used on passenger ships where such signs are required and on other passenger ships where the provision of such signs is appropriate.
5. Where symbols are used to indicate direction, or the stowage position of life-saving equipment, it is recommended that they conform in design and colour (white on a green background) with the relevant symbols in Section B and that the size of the signs is one of the preferred sizes in the British Standard referred to in paragraph 2

---

(a) BS 5378 - Safety signs and colours

SECTION - A



1. FASTEN SEAT BELT



2. SECURE HATCHES



3. START ENGINE



4.1 LOWER LIFEBOAT TO WATER



4.2 LOWER LIFERAFT TO WATER



4.3 LOWER RESCUE BOAT TO WATER



5. RELEASE FALLS



6. START WATER-SPRAY



7. START AIR SUPPLY



8. RELEASE GRIPS

SECTION - B

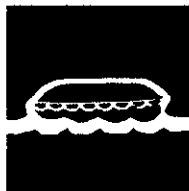

1. LIFEBOAT



2. RESCUE BOAT



3. LIFERAFT



4. DAVIT-LAUNCHED LIFERAFT



5. EMBANKMENT LADDER



5. EVACUATION SLIDE



5. EVACUATION CHUTE



5. LIFEBOUY



9. LIFEBOUY WITH LINE



10. LIFEBOUY WITH LIGHTS



11. LIFEBOUY WITH LIGHT AND SMOKE



12. LIFEJACKET



12. CHILDS LIFEJACKET



13. IMMERSION SUIT PORTABLE RADIO



14. SURVIVAL CRAFT



15. EPIRB



17. RADAR TRANSPONDER



18. SURVIVAL CRAFT PYROTECHNIC DISTRESS SIGNALS



19. ROCKET PARACHUTE FLARES



20. LINE-THROWING APPLIANCE



21. MUSTER STATION



22. EMBARKATION LADDER



19. DIRECTION INDICATOR

MSPP2  
Maritime and Coastguard Agency  
Spring Place  
105 Commercial Road  
Southampton SO15 1EG

Tel 01703 329184  
Fax 01703 329204

April 1999

MS 10/19/16

© Crown Copyright 1999



*An executive agency of the Department of the Environment, Transport and the Regions*



Maritime and Coastguard Agency

## MSN 1677 (M)

# The Merchant Shipping (Life-Saving Appliances for Ships Other Than Ships of Classes III to VI(A)) Regulations 1999

Notice to Shipowners, Certifying Authorities, Shipbuilders, Shiprepairers, Ship Masters and Surveyors

### *Summary*

This Notice advises all Shipowners, Certifying Authorities, Shipbuilders, Shiprepairers, Ship Masters and Surveyors of the new 1999 Life-Saving Appliances Regulations, as they apply to Part II of these Regulations unless otherwise specified.

#### Key Points:-

- Schedules in this Notice and regulations referred to in them are an integral part of Part II of the Merchant Shipping (Life-Saving Appliances for Ships Other than Ships of Classes III to VI(A)) Regulations 1999.
- Schedules contained in this Notice are invoked by those Regulations and are therefore a statutory obligation.

### **List of Schedules**

Schedule 1: The minimum numbers of davits to be provided and the minimum cubic capacity of lifeboats in ships of Classes II and II(A)

Schedule 2: Lifeboats

Part 1	General
Part 2	Carrying capacity of lifeboats
Part 3	Machinery of motor lifeboats
Part 4	Machinery of mechanically propelled lifeboats
Part 5	Manual pumps
Part 6	Disengaging gears

Schedule 3: Class C boats

Schedule 4: Inflated boats

Part 1	General
Part 2	Lifting arrangements
Part 3	Machinery

Schedule 5:	Liferafts	
	Part 1	Inflatable liferafts
	Part 2	Rigid liferafts
	Part 3	Liferaft launching appliances
Schedule 6:	Buoyant apparatus	
Schedule 7:	Lifebuoys	
	Part 1	General
	Part 2	Lifebuoys (SOLAS)
	Part 3	Lifebuoys (610 millimetres)
	Part 4	Lifebuoy lights
Schedule 8:	Lifejackets	
	Part 1	Lifejackets (for persons of 32 kilogrammes and more)
	Part 2	Lifejackets (for persons less than 32 kilogrammes)
Schedule 9:	Line throwing appliances	
Schedule 10:	Davits and lifeboat launching gear	
	Part 1	General
	Part 2	Construction
	Part 3	Tests after installation on board
Schedule 11:	Launching devices for inflated boats	
Schedule 12:	Part 1	Provision of equipment and rations in lifeboats, boats and liferafts
	Part 2	Equipment for inflated boats
	Part 3	Rations for lifeboats
	Part 4	Special equipment for certain motor lifeboats
	Part 5	Equipment and rations for liferafts

In this Merchant Shipping Notice –

- (1) a reference to a numbered paragraph is, unless otherwise stated, a reference to the paragraph of that number in that Part;
- (2) a reference to a numbered section is, unless otherwise stated, a reference to the section of that number in that Part;
- (3) a reference to a numbered Part is, unless otherwise stated, a reference to the Part of that number in that Schedule;
- (4) a reference to a numbered Schedule, is unless otherwise stated, a reference to the Schedule of that number in the Merchant Shipping Notice; and
- (5) a reference to the Other Ship Regulations means a reference to the Merchant Shipping (Life-Saving Appliances for Ships Other Than Classes III to VI(A)) Regulations 1999.

SCHEDULE 1

THE MINIMUM NUMBERS OF DAVITS TO BE PROVIDED AND THE MINIMUM CUBIC CAPACITY OF LIFEBOATS IN SHIPS OF CLASSES II AND II(A)

	(A)	(B)	(C)
Registered length of ship in metres	Minimum number of sets of davits	Smaller number of sets of davits authorised exceptionally	Minimum capacity of lifeboats in cubic metres
Under 37	2	2	11
37 and under 43	2	2	18
43 " " 49	2	2	26
49 " " 53	3	3	33
53 " " 58	3	3	38
58 " " 63	4	4	44
63 " " 67	4	4	50
67 " " 70	5	4	52
70 " " 75	5	4	61
75 " " 78	6	5	68
78 " " 82	6	5	76
82 " " 87	7	5	85
87 " " 91	7	5	94
91 " " 96	8	6	102
96 " " 101	8	6	110
101 " " 107	9	7	122
107 " " 113	9	7	135
113 " " 119	10	7	146
119 " " 125	10	7	157
125 " " 133	12	9	171
133 " " 140	12	9	185
140 " " 149	14	10	202
149 " " 159	14	10	221
159 " " 168	16	12	238
168 " " 177	16	12	-
177 " " 186	18	13	-
186 " " 195	18	13	-
195 " " 204	20	14	-
204 " " 213	20	14	-
213 " " 222	22	15	-
222 " " 232	22	15	-
232 " " 241	24	17	-
241 " " 250	24	17	-
250 " " 261	26	18	-
261 " " 271	26	18	-
271 " " 282	28	19	-
282 " " 293	28	19	-
293 " " 303	30	20	-
303 " " 314	30	20	-

## SCHEDULE 2

### LIFEBOATS

#### PART 1 – GENERAL

##### *Construction*

- 1.1 The lifeboat shall be constructed with rigid sides.
- 1.2 In any lifeboat fitted with a rigid shelter, the shelter shall be capable of being readily opened from both inside and outside and shall not impede rapid embarkation and disembarkation or the launching and handling of the lifeboat.
- 1.3 The lifeboat, except wooden lifeboats made of planks, shall have a block co-efficient (with the cubic capacity calculated in accordance with Part 2) of not less than 0.64: provided that any such lifeboat may have a block coefficient of less than 0.64 if there is sufficient metacentric height and freeboard when the lifeboat is loaded with its total complement of persons and equipment.
- 1.4 The lifeboat shall be of such form and proportion that it will have ample stability in a sea-way, and sufficient freeboard when loaded with its total complement of persons and equipment.
- 1.5 The lifeboat shall be so constructed that it shall be capable of maintaining positive stability when open to the sea and loaded with its total complement of persons and equipment.
- 1.6 The lifeboat shall be properly constructed for the purpose for which it is intended and shall be of sufficient strength to permit it to be safely lowered into the water when loaded with its total complement of persons and equipment. It shall be of such strength that it will not suffer residual deflection if subjected to an overload of at least 25 per cent.
- 1.7 No lifeboat shall be less than 4.9 metres in length except when it is being carried as an alternative to a Class C boat.
- 1.8 No lifeboat, when laden with its total complement of persons (calculated at 75 kilogrammes per person) and equipment, shall weigh more than 20,300 kilogrammes.
- 1.9 All thwart and side seats shall be fitted as low as is practicable, and bottom boards shall be fitted.
- 1.10 The lifeboat shall have a mean sheer at least equal to 4 per cent of its length. The sheer shall be approximately parabolic in form.
- 1.11 The lifeboat shall be fitted with internal buoyancy appliances consisting either of air cases or buoyant material not adversely affected by oil or oil products or which would otherwise adversely affect the boat.
- 1.12 In every lifeboat the total volume of the internal buoyancy appliances shall be such that it will be at least equal to the sum of –
- 1.12.1 that volume required to float the lifeboat and its total equipment when the lifeboat is flooded and open to the sea so that the top of the gunwale amidships is not submerged; and

1.12.2 10 percent of the cubic capacity of the lifeboat.

1.13 In the case of lifeboats which accommodate 100 or more persons, the volume specified in subparagraph 1.12.2 shall be increased as follows-

1.13.1 in lifeboats which accommodate from 100 to 130 persons by an amount determined by interpolating between nil at 100 persons and 1.5 per cent of the cubic capacity of the lifeboat at 130 persons; and

1.13.2 in lifeboats which accommodate over 130 persons by an amount equal to 1.5 per cent of the cubic capacity of the lifeboat.

### *Markings*

2. The dimensions of a lifeboat and the number of persons which it is permitted to accommodate shall be clearly marked on it in permanent characters. The name and port of registry of the ship to which the lifeboat belongs shall be painted on each side of the bow.

### *Equipment*

3. Every lifeboat shall be provided with equipment and rations in accordance with the provisions of Schedule 12.

**Part 1**

## **PART 2 – CARRYING CAPACITY OF LIFEBOATS**

### *Calculation of Cubic Capacity*

1.1 Subject to the provisions of paragraph 1.4, the cubic capacity of a lifeboat shall be measured in cubic metres and shall be determined by the following formula –

$$\text{Cubic Capacity} = \frac{L}{12} (4A + 2B + 4C), \text{ where –}$$

L denotes the length of the lifeboat in metres from the inside of the shell at the top of the stem to the corresponding point at the top of the stern post; in the case of a lifeboat with a square stern the length is measured to the inside of the top of the transom;

A, B, C denote respectively the areas of the cross-sections at the quarter length forward, amidships and the quarter length aft which correspond to the three points obtained by dividing L into four equal parts (the areas corresponding to the two ends of the lifeboat shall be considered negligible). They shall be deemed to be given in square metres by the successive application of the following formula to each of the three cross-sections –

$$\text{Area} = \frac{h}{12} (a + 4b + 2c + 4d + e), \text{ where –}$$

h denotes the depth measured in metres inside the shell from the keel to the level of the gunwale, or, as determined in paragraphs 1.2 and 1.3 and a, b, c, d, e denote the horizontal breadths of the lifeboat measured in metres inside the shell at the upper and lower points of the depth and at the three

points obtained by dividing h into four equal parts (a and e being the breadths at the extreme points, and c at the middle point of h).

The capacity of a square-sterned lifeboat shall be calculated as if the lifeboat had a pointed stern.

**1.2** If the sheer of the gunwale, measured at the two points situated at a quarter of the length of the lifeboat from the ends, exceeds 1 per cent of the length of the lifeboat the depth employed in calculating the area of the cross-section A or C shall be deemed to be the depth amidships plus 1 per cent of the length of the lifeboat.

**1.3** If the depth of the lifeboat amidships exceeds 45 per cent of the breadth, the depth employed in calculating the area of the amidship cross-section B shall be deemed to be equal to 45 per cent of the breadth, and the depth employed in calculating the areas of the quarter length sections A and C is obtained by increasing this last figure by an amount equal to 1 per cent of the length of the lifeboat: provided that in no case shall the depths employed in the calculation exceed the actual depths at these points.

**1.4** Unless the cubic capacity of the lifeboat is determined by exact measurement, the cubic capacity of a lifeboat constructed of wooden planks may be assumed to be the product of the length, the breadth and the depth multiplied by 0.6 provided that this formula does not give a greater capacity than that obtained by the formula set out in paragraph 1.1. The dimensions shall be measured in the following manner-

**1.4.1** Length – from the intersection of the outside of the planking with the top of the stem to the corresponding point at the stern post, or in the case of a square-sterned lifeboat, to the after side of the top of the transom;

**1.4.2** Breadth – from the outside of the planking at the point where the breadth of the lifeboat is greatest; and

**1.4.3** Depth – amidships inside the planking from the keel to the level of the top of the gunwale, but the depth used in calculating the cubic capacity may not in any case exceed 45 per cent of the breadth.

**1.5** The cubic capacity of a motor lifeboat or a lifeboat fitted with other propelling gear shall be obtained from the gross capacity by deducting a volume equal to that occupied by the motor and its accessories or the gearbox of the other propelling gear, and any equipment with which the lifeboat may be provided.

***Number of Persons That Can Be Accommodated***

**2.1** Subject to the provisions of paragraphs 2.2, 2.3, 2.4 and 2.5, the number of persons which a lifeboat shall be permitted to accommodate shall be equal to the greatest whole number obtained by dividing the capacity in cubic metres calculated in accordance with Part 2 by –

in the case of a lifeboat of 7.3 metres in length or over	0.283
in the case of lifeboats of 3.7 metres in length	0.453
in the case of lifeboats of 3.7 metres in length but under 7.3 metres	a number between 0.453 and 0.283 to be obtained by interpolation.

2.2 The number of persons which a lifeboat shall be permitted to accommodate shall in no case exceed the number of adult persons wearing lifejackets which can be seated without in any way interfering with the use of oars or the operation of other propulsion equipment.

2.3 No lifeboat shall be permitted to accommodate more than 150 persons.

2.4 No lifeboat shall be permitted to accommodate more than 100 persons unless it is a motor lifeboat.

2.5 No lifeboat shall be permitted to accommodate more than 60 persons unless it is a motor lifeboat or a mechanically-propelled lifeboat.

Other Ships Regulations  
regs 7, 8, 10, 11 and 12

### PART 3 – MACHINERY OF MOTOR LIFEBOATS

#### *General*

1.1 The engine shall be capable of being readily started in cold weather and of running reliably under conditions of extremes of temperature.

1.2 The engine shall operate properly under conditions of at least 10 degrees list and 10 degrees trim. Circulating water pumps where fitted shall be self-priming.

1.3 The engine and its accessories, including the fuel tank, pipes and fittings, shall be adequately protected to ensure reliable operation under conditions likely to arise at sea during adverse weather. The engine casing shall additionally be fire-resisting, and in the case of air-cooled diesel engines shall be so designed that the supply of cooling air is not restricted.

#### *Construction*

2.1 Means shall be provided to prevent the spread of oil. In a wooden lifeboat a metal tray shall be fitted under the engine.

2.2 The fuel tank shall be substantially constructed, securely fixed in position with a metal tray underneath and fitted with suitable filling, vapour venting and relief arrangements. No part of the tank or its connections nor any part of the fuel piping or fittings shall depend on soft solder for tightness, and tanks made of steel shall be protected externally against corrosion by sea water by metal spraying or similar means. The tank and its connections shall be capable of withstanding hydraulic pressure corresponding to a head of at least 45 kiloPascals. A cock shall be fitted at each end of the fuel pipe.

2.3 The engine and fuel tank spaces shall be efficiently ventilated.

2.4 The shafting and other moving parts shall be fenced where necessary to protect the persons in the lifeboat from injury.

### *Propulsion*

3. Every motor lifeboat shall be –

- 3.1 fitted with a compression engine which shall be kept ready for use at all times;
- 3.2 provided with sufficient fuel for 24 hours continuous operation at the speed specified in paragraphs 3.4 and 3.5;
- 3.3 capable of going astern;
- 3.4 if it is a lifeboat to be carried in passenger ships, tankers, ships employed as whale factory ships, ships employed as fish processing or canning factory ships and ships engaged in the carriage of persons employed in the whaling, fish processing or canning industries capable of going ahead in smooth water when loaded with its total complement of persons and equipment at a speed of 6 knots; and
- 3.5 if it is any other lifeboat, capable of going ahead under the conditions specified in the preceding subparagraph at a speed of 4 knots.

Other Ships Regulations  
reg 10

## **PART 4 – MACHINERY OF MECHANICALLY PROPELLED LIFEBOATS**

### *General*

1. The propelling gear shall –

- 1.1 be so arranged that it can be rapidly and easily made ready for service and will not interfere with the rapid embarkation of persons into the lifeboat;
- 1.2 be capable of being operated by persons untrained in its use and shall be capable of being operated when the lifeboat is flooded; and
- 1.3 not require adjustment to enable it to be worked by persons of different stature. It shall be effective in propelling the lifeboat partially or fully loaded.

### *Construction*

2. The propelling gear shall be substantially constructed and fitted to the lifeboat in an efficient manner. The metal part of any operating handle shall be suitably sheathed by material other than wood to ensure that the hands of the operators are protected in conditions of extreme cold.

### *Design*

- 3.1 The propelling gear shall be of sufficient power to enable the lifeboat, when loaded with its equipment and with a distributed weight equal to the total number of persons it is certified to carry, to be propelled at a speed ahead of at least 3.5 knots in smooth water over a distance of a quarter of a mile.

3.2 The propelling gear shall be capable of propelling the lifeboat ahead or astern and a device shall be fitted by means of which the helmsman can cause the lifeboat to go astern or ahead at any time when the propelling gear is in operation.

Schedule 12

#### PART 5 – MANUAL PUMPS

1. The capacity of the pump when operated at not more than 60 double strokes per minute at 1.2 metres suction head shall be not less than –
  - 1.1 30 litres per minute in lifeboats of 7 metres in length or over; or
  - 1.2 20 litres per minute in lifeboats of less than 7 metres length.
2. The pump shall be self-priming when operated at a suction head of not less than 1.2 metres.
3. All parts of the pump shall be of material unaffected by the corrosive effects of sea water.
4. The interior of the pump, including valves, shall be readily accessible for emergency cleaning and the cover for access shall be capable of being easily removed without the use of a spanner or other special tool.
5. The pump branches shall be suitable for use with rubber hose connections of at least 30 millimetres bore.
6. The metal part of the operating handle shall be suitably sheathed by material other than wood to ensure that the hands of the operator are protected when the pump is used in extreme cold.
7. The spindle gland shall be of the spring-loaded seal ring type.

Other Ships Regulations  
reg 28

#### PART 6 – DISENGAGING GEARS

1. Lifeboat disengaging gears shall be so arranged as to ensure simultaneous release of both ends of the lifeboat.
2. The means of effecting release shall be placed aft.
3. The gear shall be of a type which will permit the release of the lifeboat only when it is waterborne.
4. The gear shall be of a type which will permit release when there is a towing strain on the link or falls.
5. The hooks shall be suitable for instant unhooking by hand.
6. The point of attachment of the hook to the eye, ring of link or the block shall not be lower than when ordinary fixed hooks are fitted.
7. The gear and mechanism for effecting release shall be so constructed and arranged as to ensure the safety of the lifeboat independently of any safety pins.

8. The means for effecting release shall be by hauling on or letting go a line or by using a lever. If release is effected by a pull upon a line the line shall be properly cased in. Rods or other connections between hooks shall also be cased in whenever this is necessary for the safety or the efficient action of the gear or for the protection of persons from injury. The fairleads shall be properly arranged to prevent the lines from jamming or nipping and shall be strongly attached to permanent parts of the lifeboat. The lines shall be fitted with chains where necessary for efficiency.
9. Those parts of the gear likely to be seized by rust or corrosion shall be made of non-corrodible metal.
10. No part of the gear taking the weight of the lifeboat shall be made of cast metal.
11. The scantlings and proportions of those parts which support the weight of the lifeboat shall have a breaking strength proportionate to a load of at least 2.2 times the weight of the heaviest loaded lifeboat the gear is intended to serve.

**SCHEDULE 3**  
**CLASS C BOATS**

**Construction**

- 1.1 Every Class C boat shall be an open boat constructed with rigid sides.
- 1.2 The boat shall be of such form and proportion that it will have ample stability in a sea-way and sufficient freeboard when loaded with its equipment and the number of persons specified in column (2) of paragraph 1.3.
- 1.3 The length of the boat and the number of persons for whom seating is provided in the boat shall be determined in accordance with the following table –

(1) Length of boat in metres	(2) Minimum Seating Capacity of boat
4.8	9
4.5	8
4.2	7
3.9	5
3.6	4

- 1.4 All thwart and side seats in the boat shall be fitted as low as is practicable and bottom boards shall be fitted.
- 1.5 The boat shall be square-sterned and shall have a mean sheer at least equal to five per cent of its length.
- 1.6 The boat shall be fitted with internal buoyancy appliances which shall be so placed as to ensure stability when the boat is fully laden under adverse weather conditions.
- 1.7 The boat shall be fitted with internal buoyancy appliances consisting of either air cases or buoyant material not adversely affected by oil or oil products, neither of which shall adversely affect the boat.
- 1.8 The total volume of the internal buoyancy appliances shall be such that it will be at least equal to the sum of –

1.8.1 that volume required to float the boat and its full equipment when the boat is flooded and open to the sea so that the top of the gunwale amidships is not submerged; and

1.8.2 7.5 per cent of the cubic capacity of the boat.

**Marking**

2. The dimensions of a Class C boat and the number of persons which it is permitted to accommodate shall be clearly marked on it in permanent characters. The name and port of registry of the ship to which the boat belongs shall be painted on each side of the bow.

**Equipment**

3. Every Class C Boat shall be provided with equipment and rations in accordance with the provisions of Schedule 12.

## SCHEDULE 4

### INFLATED BOATS

#### PART 1 – GENERAL

##### *Construction*

- 1.1** The overall length of every inflated boat shall be not less than 3.8 metres and the boat shall be of such form and proportion that it will have ample stability in a seaway when afloat in the empty, laden or swamped condition. The boat shall be suitable for the accommodation of at least six persons.
- 1.2** The boat shall be so constructed as to remain, when fully loaded, seaworthy and afloat for 30 days under temperatures between +60°C and –30°C and in weather likely to be encountered at sea anywhere in the world.
- 1.3** The materials and components used in the construction of the boat and its accessories shall be able to withstand the climatic conditions referred to in paragraph 1.2. The boat and its accessories shall be resistant to the effects of humidity when stowed on board a vessel and all fabrics, cordage, webbing and thread shall be rotproof. The boat shall be so constructed that it is not adversely affected by oil or oil products.
- 1.4** The performance of the boat should not be affected for at least 24 months if it is stowed on deck with only minimum protection from the weather.
- 1.5** The main buoyancy chambers forming the boundary of the boat shall on inflation provide at least 0.17 cubic metres of volume for each person the boat is certified to accommodate. The diameter of the main buoyancy chambers of single tube boats shall be at least 0.43 metres.
- 1.6** The main buoyancy chambers shall be divided so that there are at least two compartments along each side and one compartment in the bow.
- 1.7** In boats with more than one buoyancy chamber, no chamber shall exceed 60 per cent of the total volume required.
- 1.8** At least one thwart shall be fitted so that the boat can be rowed satisfactorily.
- 1.9** The floor of the boat shall be waterproof and provide an efficient working platform.
- 1.10** A transom, which shall not be inset by more than 20 per cent of the overall length of the boat, shall be provided.
- 1.11** A bow cover in a highly visible colour extending for at least 15 per cent of the overall length of the boat shall be provided.
- 1.12** A non-return valve shall be fitted to each buoyancy chamber for manual inflation.
- 1.13** A relief valve designed to operate at a pressure not exceeding 125 per cent of the designed working pressure of the buoyancy chamber shall be fitted in each buoyancy chamber. Means for deflating each chamber shall be fitted.
- 1.14** Drainage arrangements shall be provided which are capable of draining the boat, when flooded, within 2 minutes. To the extent that the water levels inside and outside the boat are the same it shall not be possible accidentally to flood the boat through these drainage arrangements.

### *Marking*

2. The transom of an inflated boat shall be marked with the number of persons it is permitted to accommodate, its date of manufacture, makers name and trade mark, serial number and name and port of registry of the ship on which it is carried.

### *Equipment*

3. Every inflated boat shall be provided with equipment and rations in accordance with the provisions of Schedule 12.

Other Ships Regulations  
reg 22

## **PART 2 – LIFTING ARRANGEMENTS**

1. Bridle slinging arrangements shall be fitted to all inflated boats to enable the boat to be lowered or raised from the water. The bridle sling shall comprise four legs or more which should be joined at the top in the form of an eye or be connected to a lifting ring or shackle. The arrangement shall be such that the boat is stable when suspended and –

1.1 when the bridle has a four-legged sling, the legs must be of equal length; or

1.2 the bridle is permanently attached; or

1.3 the arrangements are such that it is not possible to connect any of the bridle legs to the wrong position on the boat.

2. The bridle shall be manufactured of a material which will not adversely affect the material of the boat and be sheathed, if necessary, to prevent abrasion of the fabric.

3. The forward lifting attachments shall be securely fastened to the hull, either by bands passing under the hull to the tops of the buoyancy tubes and terminating in D rings, or by eyes to take bridle slings.

4. The after lifting attachments shall be connected to the hull in a similar way as the forward lifting attachments, or they may be made direct to the transom.

5. The bridle slinging arrangements shall be such that their breaking tensile strength is at least 6 times the maximum work in load as defined in paragraph 1 of Schedule 11, excluding the weight of the blocks and falls.

6. The bridle sling lifting arrangements shall be proof tested to not less than 2.5 times their respective working loads. The proof testing can be carried out either –

6.1 individually on each item associated with the lifting arrangements, or

6.2 on the boat completely assembled with its lifting arrangements and bridle sling. In each case fabric, webbings and cordages forming part of the lifting arrangements shall have a breaking strength of not less than six times their respective working loads.

### PART 3 – MACHINERY

#### *Propulsion*

1. The engine shall be capable of being readily started by manual means in cold weather and of running reliably under conditions of extremes of temperature.
2. The engine and its accessories, including the fuel tank, pipes and fittings shall be protected to ensure reliable operation under conditions likely to arise at sea during adverse weather conditions.
3. The fuel tank shall be substantially constructed, securely fixed in position and fitted with suitable filling vapour venting and relief arrangements. Tanks made of steel shall be protected externally against corrosion by sea water by metal spraying or similar means. The tank and its fittings shall be capable of withstanding a hydraulic pressure of at least 45 kilopascals. A cock shall be fitted at each end of any fixed fuel pipe, and where portable pipes are provided a means for preventing leakage of fuel on disconnection of the pipes shall be fitted.
4. Engines fitted to inflated boats shall have sufficient power for its purpose.
5. Engines shall be permanently attached to the boats they are intended to propel unless they weigh less than 40 kilogrammes and the total weight of the engine, fuel tank and fuel does not exceed 60 kilogrammes.

## SCHEDULE 5

### LIFERAFTS

#### PART 1 – INFLATABLE LIFERAFTS

##### *General*

- 1.1 The liferaft shall be capable of being readily righted by one person if it inflates in an inverted position.
- 1.2 The liferaft shall be inflated by a gas which is not injurious to the occupants and the inflation shall take place automatically either on the pulling of a line or by some other equally simple and efficient method. Means shall be provided whereby a topping-up pump or bellows can be used to maintain pressure.
- 1.3 The liferaft shall be of suitable material and construction and shall be so constructed as to withstand exposure for 30 days afloat in all sea conditions.
- 1.4 The liferaft shall be capable of operating in the temperature range +65°C to –30°C.
- 1.5 The liferaft shall be so stowed as to be readily available in case of emergency. It shall be stowed in such a manner as to permit it to float free from its stowage, inflate and break free from the vessel in the event of sinking.
- 1.6 If used, lashings shall be fitted with an automatic release system based on hydrostatic principles, or equivalent.
- 1.7 Notwithstanding paragraph 1.5, liferafts stowed forward or aft additional to normal requirements may be securely fastened.

##### *Construction*

- 2.1 The liferaft shall be so constructed that, when fully inflated and floating with the cover uppermost, it shall be stable in a seaway.
- 2.2 The liferaft shall be so constructed that if it is dropped into the water from a height of 18 metres neither the liferaft nor its equipment will be damaged. If the raft is to be stowed on the ship at a height above the water of more than 18 metres it shall be of a type which has been satisfactorily drop-tested from a height at least equal to the height at which it is to be stowed.
- 2.3 The construction of the liferaft shall include a cover which shall automatically be set in place when the liferaft is inflated. This cover shall be capable of protecting the occupants from exposure, and means shall be provided for collecting rain. A lamp which derives its luminosity from a sea-activated cell shall be fitted on top of the cover; and a similar lamp shall also be fitted inside the liferaft. The cover of the liferaft shall be of a highly visible colour.
- 2.4 The liferaft shall be fitted at each opening with efficient means to enable persons in the water to climb on board.
- 2.5 The buoyancy of the liferaft shall be provided by an even number of separate compartments, half of which shall be capable of supporting out of the water the number of persons which the liferaft is permitted to accommodate. Other equally efficient designs will be acceptable if they provide a reasonable margin of buoyancy when the raft is damaged or partially fails to inflate.

- 2.6** The total weight of the liferaft, its valise or other container and its equipment shall not exceed 180 kilogrammes.
- 2.7** The number of persons which an inflatable liferaft shall be permitted to accommodate shall be equal to –
- 2.7.1** the greatest whole number obtained by dividing by 0.096 the volume, measured in cubic metres, of the main buoyancy tubes (which for this purpose shall include neither the arches nor the thwart or thwarts if fitted) when inflated; or
  - 2.7.2** the greatest whole number obtained by dividing by 0.372 the area measured in square metres of the floor (which for this purpose may include the thwart or thwarts if fitted) of the liferaft when inflated, whichever number shall be the less.
- 2.8** The floor of the liferaft shall be waterproof and shall be capable of being sufficiently insulated against cold either –
- 2.8.1** by means of one or more compartments which the occupants can inflate if they so desire, or which inflate automatically and can be deflated and re-inflated by the occupants; or
  - 2.8.2** by other equally efficient means not dependent on inflation.
- 2.9** Every liferaft which is designed for use with a launching appliance shall be properly constructed for the purpose for which it is intended and it shall have sufficient strength to permit it to be safely lowered into the water when loaded with its total complement of persons and equipment.
- 2.10** The liferaft shall have a carrying capacity calculated in accordance with paragraph 2.7 but in no case permitted to accommodate less than six persons or more than twenty-five persons.
- 2.11** The liferaft shall be fitted with arrangements enabling it to be readily towed.
- 2.12** In ships of Classes IX(A), IX(A)(T) and in ships of Class XII of less than 21.3 metres in length the requirements of paragraphs 1.4, 2.2, 2.3, 2.8, 2.10 and 2.11 may be modified as follows –
- 2.12.1** the temperature of  $-30^{\circ}\text{C}$  referred to in paragraph 1.4 may be taken to be minus  $18^{\circ}\text{C}$ ;
  - 2.12.2** the height of 18 metres referred to in paragraph 2.2 may instead be taken to be the height of the deck on which the liferaft is stowed above the ship's light water line, but in no case less than 6 metres;
  - 2.12.3** means for collecting rain referred to in paragraph 2.3 need not be provided;
  - 2.12.4** the method for insulating the floor of the liferaft against cold referred to in paragraph 2.8 need not be complied with;
  - 2.12.5** the minimum carrying capacity of liferafts required by paragraph 2.10 may be reduced to four persons, provided that liferafts to accommodate less than six persons shall only be carried on ships where the total number of persons on board is less than six; and
  - 2.12.6** the arrangements for towing referred to in paragraph 2.11 need not be provided.
- 2.13** In ships of Classes VIII(A), VIII(A)(T) and XI, in ships of Class IX not being ships of 500 tons or over engaged on an international voyage and in ships of Class XII of 21.3 metres in length or over the requirements of paragraph 2.10 may be modified in accordance with subparagraph 2.12.5.

### *Fittings*

- 3.1 The liferaft shall be fitted with a painter and shall have a lifeline becketed round the outside. A lifeline shall also be fitted round the inside of the liferaft.
- 3.2 The liferaft shall be contained in a valise or other container so constructed as to be capable of withstanding hard wear under conditions met with at sea. The liferaft in its valise or other container shall be inherently buoyant.
- 3.3 The liferaft shall be provided with arrangements for adequately siting and securing in the operating position the antenna provided with the portable radio apparatus where this is carried.

### *Markings*

4. The number of persons which an inflatable liferaft is permitted to accommodate shall be clearly marked in permanent characters on the outside of the liferaft canopy and on the valise or other container in which the liferaft is stowed. Every such liferaft shall also bear a serial number and the manufacturer's name. The name and port of registry of the ship on which the raft is for the time being carried, or a serial number to enable that ship to be identified, shall be also be marked on the liferaft and its valise or other container.

### *Equipment*

5. Every liferaft shall be provided with equipment and rations in accordance with the provisions of Schedule 12.

Other Ships Regulations  
regs 7, 8, 10, 11, 17, 18, 20 and 21

## **PART 2 – RIGID LIFERAFTS**

### *General*

- 1.1 The liferaft shall be fitted with a cover or some other equivalent arrangement which is of a highly visible colour, and is capable of protecting the occupants from exposure whichever way up the liferaft is floating.
- 1.2 The liferaft shall at all times be effective and stable when floating either way up.
- 1.3 Liferafts shall be so stowed as to float free in the event of the ship sinking.

### *Construction*

- 2.1 The liferaft shall be so constructed that, if it is dropped into the water from its stowed position, neither the liferaft nor its equipment will be damaged.
- 2.2 Any liferaft which is designed for use with a launching appliance shall be properly constructed for the purpose for which it is intended and shall be of sufficient strength to permit it to be safely lowered into the water when loaded with its total complement of persons and equipment.
- 2.3 The liferaft shall be so constructed that its air cases or buoyant material are placed as near as possible to its sides.
- 2.4 The deck area of the liferaft shall be situated within that part of the liferaft which affords protection to its occupants. The nature of the deck shall be such as to prevent, so far as practicable, the ingress of water and it shall effectively support the occupants out of the water.

2.5 The total weight of any liferaft and its equipment carried in a passenger ship shall not exceed 180 kilogrammes. Liferafts carried in cargo ships may exceed 180 kilogrammes in weight if they are capable of being launched from both sides of the ship or if mechanical means are provided for lowering them into the water.

2.6 The number of persons which the liferaft shall be permitted to accommodate shall be equal to –

2.6.1 the greatest whole number obtained by dividing by 96 the volume, in cubic decimetres, of the air cases or buoyant material; or

2.6.2 the greatest whole number obtained by dividing by 0.3720 the deck area of the liferaft measured in square metres, whichever number shall be the less.

2.7 The liferaft shall be fitted at each opening with efficient means to enable persons in the water to climb on board.

2.8 The liferaft shall be so constructed as not to be affected by oil or oil products.

2.9 The liferaft shall be fitted with arrangements enabling it to be readily towed.

### *Equipment*

3.1 The equipment of the liferaft shall be so stowed as to be readily available whichever way up the liferaft is floating.

3.2 The liferaft shall have a painter attached and a lifeline securely becketed round the outside. A lifeline shall also be fitted round the inside of the liferaft.

3.3 A buoyant light of the electric battery type shall be attached to the liferaft by a lanyard.

3.4 The liferaft shall be provided with arrangements for adequately siting and securing in the operating position the antenna provided with the portable radio apparatus where this is carried.

### **Markings**

4. Every rigid liferaft shall be marked with the name and port of registry of the ship in which is carried, and with the number of persons which it is permitted to accommodate.

Other Ships Regulations  
reg 29

## **PART 3 – LIFERAFT LAUNCHING APPLIANCES**

### *General*

1. In this Part the expression “working load” means the sum of the weight of the liferaft and its equipment, all other associated gear that is supported by the launching appliance during the launching operation and the maximum number of persons which the liferaft is permitted to accommodate the weight of each person being taken to be 75 kilogrammes.

### *Strength*

2. Every liferaft launching appliance and all associated gear which, during the launching operation, is subjected to the working load or to a load imposed due to the working load, shall be of such strength that the liferaft when loaded with its total complement of persons and equipment can be safely lowered when the ship has a trim of up to 10 degrees and is listed up to 15 degrees either way.

### ***Construction***

3. The design of each part of the appliance shall be such that when operating under the working load and unfavourable conditions of list and trim it shall have an adequate factor of safety. Except for lead sheaves and block sheaves, all parts of the appliance and its associated gear which are subjected to the working load, or on which the safety of the appliance or the liferaft while in the process of launching depends, shall be constructed of ductile material; and no part, other than lead sheaves and block sheaves, shall be constructed of cast metal unless its use has been properly assessed.

### ***Static Load Test***

4. Every liferaft launching appliance shall be capable of withstanding a static load test of not less than 2.2 times the working load.

### ***Operation***

5.1 Every liferaft launching appliance shall be so designed that the liferaft when loaded with its total complement of persons and equipment can be safely lowered into the water.

5.2 The speed of lowering of the liferaft shall be automatically controlled between 0.3 metres per second and 0.6 metres per second. The descent of the liferaft shall be at all times under the manual control of the operator.

5.3 The use of a launching appliance shall not depend on any one method of operation unless that method is manual effort or gravity. The arrangements shall be such that the liferaft can always be lowered by gravity.

5.4 On becoming waterborne the liferaft shall be automatically released from the launching appliance. In addition there shall be provision for the manual release of the liferaft by a person on board the liferaft.

5.5 When liferaft launching appliances incorporate winches, the winches shall be constructed in accordance with paragraph 10 of Part 2 of Schedule 10.

### ***Lowering Tests***

6. Every liferaft launching appliance shall be tested by lowering, from the embarkation position into the water, the largest liferaft it is intended to serve, loaded with its full equipment, a distributed weight equal to the total number of persons it is permitted to accommodate plus 10 per cent of the working load.

### ***Operational Tests***

7. Every launching appliance shall be tested to ensure that any liferaft it serves, when loaded only with its full equipment, can be lowered by gravity into the water. If more than one liferaft is served by an appliance, each shall be tested.

Other Ships Regulations  
regs 17 and 18

## **SCHEDULE 6**

### **BUOYANT APPARATUS**

### ***Construction***

1.1 A buoyant apparatus shall be of such construction that it retains its shape and properties when exposed to the weather on board ship and when in the water. It shall be constructed so as

not to require adjustment prior to use.

1.2 It shall be capable of withstanding a drop test, the height of which shall be the distance between the deck on which it is stowed and the waterline corresponding to the ship's lightest sailing condition but in no case less than the following –

apparatus carried in ships of Class I . . . . .	18 metres
apparatus carried in ships of Class III . . . . .	6 metres

1.3 Buoyant apparatus shall be effective and stable when floating either way up. They shall be capable of supporting a weight of iron, suspended in fresh water from the grab lines referred to in paragraph 1.5, of 22.5 kilogrammes per metre of length along any edge (subject to a minimum of 29 kilogrammes) without immersing any part of their upper surfaces.

1.4 The air cases or other equivalent provision for buoyancy shall be placed as near as possible to the sides of the apparatus. Buoyancy is not to be dependent upon inflation and any material providing buoyancy shall not be adversely affected by oil or oil products.

1.5 Grab lines shall be fitted all round the apparatus so as to provide an equal number of loops corresponding to the total number of persons the apparatus is capable of supporting. Each loop shall have a cork or light wood float and the depth of the loop when wet shall not be less than 150 millimetres or more than 200 millimetres. On apparatus exceeding 305 millimetres in overall depth two rows of grab lines shall be fitted, one having its points of attachment below the top of the air cases and the other above the bottom of the air cases and as close to the sides of the air cases as is practicable. On apparatus of 305 millimetres or less in overall depth one row of grab lines may be attached along the line at mid-depth. The grab lines shall be of rope of not less than 14 millimetres in diameter. The ropes may be passed through holes in the framing, interlaced to prevent movement; or attached by means of wrought iron or steel fastenings. Whichever method is adopted the attachment shall be strong enough to permit the apparatus being lifted by the grab lines.

1.6 Every buoyant apparatus shall be fitted with a painter.

1.7 A buoyant apparatus shall not exceed 180 kilogrammes in weight unless suitable means are provided to enable it to be launched without lifting by hand. If the weight of the apparatus exceeds 136 kilogrammes suitable handles or rungs shall be fitted for this purpose.

1.8 Buoyant apparatus carried in ships of Class 1 shall not be less than 1070 millimetres in breadth.

1.9 The number of persons which a buoyant apparatus shall be considered capable of supporting shall be equal to the lesser of –

1.9.1 the greatest whole number obtained by dividing by 14.5 the number of kilogrammes of iron which the apparatus is capable of supporting from its grab lines in fresh water; or

1.9.2 the greatest whole number obtained by dividing the perimeter in metres by 0.3.

**Marking**

2. The number of persons which a buoyant apparatus is permitted to accommodate shall be clearly marked on it in permanent characters

## SCHEDULE 7

### LIFEBUOYS

#### PART 1 – GENERAL

1. Every lifebuoy made of plastic or other synthetic compounds shall be capable of retaining its buoyant properties and durability in contact with sea water or oil products, or under any world-wide variation of temperature or climatic changes.
2. A lifebuoy shall not be filled with rushes, cork shavings, granulated cork or any other loose granulated material, and its buoyancy shall not depend upon compartments which require to be inflated.
3. Every lifebuoy shall be of a highly visible colour.
4. Every lifebuoy shall be marked in block letters with the name and, except in the case of ships of Class XII, the port of registry of the ship in which it is carried. Lifebuoys constructed of materials other than cork shall be permanently marked with the manufacturer's trade name for that product.
5. Lifebuoys shall always be capable of being rapidly cast loose and shall not be permanently secured in any way.
6. Lifebuoys shall weigh not less than 4 kilogrammes where the release of a self-igniting light depends upon the weight of the lifebuoy.

Other Ships Regulations  
regs 23(1) and (2)

#### PART 2 – LIFEBUOYS (SOLAS)

1. Lifebuoys shall comply with the requirements of Part I and, in addition, with the requirements of this Part.
2. Every lifebuoy shall be constructed of cork, evenly formed and securely plugged, or of other equally efficient buoyant material which shall not be adversely affected by oil or oil products, and shall be capable of floating in fresh water for at least 24 hours with 14.5 kilogrammes of iron suspended from it.
3. The inside diameter of a lifebuoy shall be 455 millimetres and the outside diameter 760 millimetres. The major axis of the section shall be 150 millimetres. The minor axis of the section shall be 100 millimetres.
4. Every lifebuoy shall be fitted with beackets securely seized and with grab lines which shall be of good quality unkinkable line and well secured at four equidistant points providing four loops of line each not less than 700 millimetres long.
5. The weight of a lifebuoy shall not exceed 6.15 kilogrammes when newly constructed.

Other Ships Regulations  
reg 23(2) and (3)

#### PART 3 – LIFEBUOYS (610 millimetres)

1. Every lifebuoy shall be constructed of cork, evenly formed and securely plugged, or of other equally efficient buoyant material which shall not be adversely affected by oil or oil products, and shall be

capable of floating in fresh water for at least 24 hours with 10.45 kilogrammes of iron suspended from it.

2. The inside diameter of the lifebuoy shall be 355 millimetres and the outside diameter 610 millimetres. The major axis of the section shall be 125 millimetres and the minor axis from 89 to 100 millimetres.

3. Every lifebuoy shall be fitted with beackets securely seized, and with grablines of good quality unkinkable line and well secured at four equidistant points providing four loops of line each not less than 510 millimetres long.

4. The weight of a lifebuoy shall not exceed 3.40 kilogrammes when newly constructed.

Other Ships Regulations  
reg 24

#### PART 4 – LIFEBOUYS LIGHTS

1. Self-igniting lights attached to lifebuoys shall be such that they cannot be extinguished in water. They shall be capable of burning for not less than 45 minutes and shall have a luminous intensity of not less than 2 candelas in all directions of the upper hemisphere and comply with the following minimum ranges of light visibilities in the given atmospheric conditions –

Atmospheric transmissivity factor	Meteorological range of visibility (miles)	Range of visibility of the light (miles)
0.3	2.4	0.96
0.4	3.3	1.05
0.5	4.3	1.15
0.6	5.8	1.24
0.7	8.4	1.34
0.8	13.4	1.45
0.9	28.9	1.57

2. Self-igniting lights attached to lifebuoys carried in tankers shall be of an electric battery type.

## SCHEDULE 8

### LIFEJACKETS

#### PART 1 – LIFEJACKETS (FOR PERSONS OF 32 KILOGRAMMES AND MORE)

1. Every life jacket for use by a person weighing 32 kilogrammes or more shall provide a minimum of 155 Newtons buoyancy in fresh water for 24 hours, after which time the performance requirements detailed in paragraph 3 shall not be reduced by more than 5 per cent.
2. Every such lifejacket shall be marked indelibly on both sides in letters not less than 12 millimetres in height, with the words “PERSON OF 32 KILOGRAMMES OR MORE” and, on one side only, with the maker’s name or other identification mark.
3. Every such lifejacket shall –
  - 3.1 be so constructed as to eliminate, as far as possible, all risk of it being put on incorrectly, and it shall be capable of being worn inside out;
  - 3.2 turn the wearer in still water, within 5 seconds, from any position to a safe floating position, with the body inclined backwards from its vertical floating position and supporting the mouth of the conscious or unconscious wearer 150 millimetres above the water;
  - 3.3 not be adversely affected by oil or oil products;
  - 3.4 be of a highly visible colour;
  - 3.5 be fitted with a ring or loop or similar device of adequate strength to facilitate rescue;
  - 3.6 be made of materials of low flammability and the fabric with which it is covered and its tapes shall be rotproof;
  - 3.7 be fitted with an approved whistle firmly attached by a lanyard;
  - 3.8 have fastening tapes securely attached to the lifejacket cover which comply with British Standards Specification No. BS 5F 49: 1991 and are capable of taking a load of 140 kilogrammes. The method of fastening the tapes shall be easily understood and capable of being readily put into practice. Metal fastenings when used shall be of a size and strength consistent with the fastening tapes and of corrosion resistant material; and
  - 3.9 allow the wearer to jump a vertical distance of 6 metres into the water without injury and without dislodgement of the lifejacket.
4. The buoyancy of every such lifejacket shall be provided by kapok or other equally effective buoyant material.
5. Every kapok lifejacket, in addition to complying with the requirements of paragraphs 1 to 4, shall –
  - 5.1 contain not less than 1 kilogramme of kapok;
  - 5.2 contain kapok of good flotation quality, well teased, evenly packed and free from seeds and other foreign matter;
  - 5.3 be such that the kapok is protected from the effects of oil or oil products to the extent that

the loss of buoyancy in the lifejackets, after floating in disturbed water containing a layer of not less than 3 millimetres in depth of a mixture of gas oil for a period of 48 hours, shall not exceed 2 per cent of the initial buoyancy. For the purpose of this test the lifejacket shall be loaded with weights equal to half its initial buoyancy; and

5.4 be covered with pre-shrunk cotton material or a suitable synthetic material the weight of which in loom state per linear metre shall be not less than 186 grammes for a width of 685 millimetres, and in proportion for other widths. The fabric shall be free from admixture of sizing or other foreign matter. The threads per 10 centimetres in loomstate shall be warp 173 two-fold threads and weft 133 two-fold threads. The sewing shall be carried out with thread of undyed linen yarn having a count of 25 lea, 3 cord reverse twist (resultant Tex count 66), satin finish and complying with the specifications in Clauses 2, 3 and 4 (except subparagraph 4(a)) of British Standards Specification No. BS 5F 49 : 1991 for thread of that count.

6. Every lifejacket using a buoyant material other than kapok, in addition to complying with the requirements of paragraphs 1 to 4 and 5.4, shall be constructed with material –

6.1 weighing not more than 190 kilogrammes per cubic metre, and of good quality and clean. If the material is in pieces, the size of each piece shall be not less than 165 cubic centimetres, unless such pieces are in layer form and are fastened together with an approved adhesive; and

6.2 that is chemically stable.

#### **PART 2 – LIFEJACKETS (FOR PERSONS LESS THAN 32 KILOGRAMMES)**

1. Every lifejacket for use by a person weighing less than 32 kilogrammes shall provide a minimum buoyancy of 66.7 Newtons in fresh water for 24 hours, after which time the performance requirements detailed in paragraph 3 of Part 1 shall not be reduced by more than 5 per cent.

2. Every such lifejacket shall be marked indelibly on both sides, in letters not less than 12 millimetres in height, with the words “FOR PERSON UNDER 32 KILOGRAMMES” and on one side only with the maker’s name and other identification mark.

3. Every such lifejacket shall comply with the requirements of paragraphs 3 and 4 of Part 1.

4. Every such kapok lifejacket shall contain not less than 425 grammes of kapok and comply with the requirements of paragraphs 5.2, 5.3 and 5.4 of Part 1.

5. Every such lifejacket using a buoyant material other than kapok shall comply with paragraphs 5.4, 6.1 and 6.2 of Part 1.

## SCHEDULE 9

### LINE-THROWING APPLIANCES

#### *General*

- 1.1 The lines and the rockets, together with the means of igniting them, shall be kept in cases suitable for providing protection from the weather.
- 1.2 All components, compositions and ingredients of the rockets and the means of igniting them shall be of such character and quality as to enable them to maintain their serviceability under good average storage conditions in the marine environment for a period of at least three years.
- 1.3 The date of manufacture and the date of expiry shall be marked indelibly on the rockets and these date markings shall be similarly stamped on the cartridges.
- 1.4 Clear and concise directions for use in English, supported by illustrations, shall be marked on the appliance.

#### *Construction*

- 2.1 Every line-throwing appliance shall consist of a rocket pistol and four individual rockets with four lines, or four separate self-contained units each of which contains a rocket and line ready for use.
- 2.2 The appliance shall be so constructed that the end from which the rocket is ejected can be positively identified by day or night.
- 2.3 The lines shall have a breaking load of not less than 2,000 Newtons.
- 2.4 Every appliance shall be capable of throwing a line of no less than 4 millimetres in diameter for a distance of 230 metres in calm weather.
- 2.5 Every appliance shall be capable of throwing the line in such a manner that the lateral deflection on either side of the direction of firing does not exceed 10 per cent of the length of flight of the rocket in calm weather.
- 2.6 The rocket (in the case of a pistol-fired rocket) or the assembly (in the case of an integral rocket and line) shall function after immersion for 1 minute under 10 centimetres of water.

## SCHEDULE 10

### DAVITS AND LIFEBOAT LAUNCHING GEAR

#### PART 1 – GENERAL

##### *General*

1. In this Schedule the expression “working load” means –
  - 1.1 in relation to davits to which paragraph 1.1 of Part 2 applies, the total weight of the lifeboat, its full equipment, the blocks and falls, and the maximum number of persons which the lifeboat is permitted to carry, the weight of each person being taken to be 75 kilogrammes;
  - 1.2 in relation to davits and other means of launching to which paragraph 1.2 or 1.3 of Part 2 applies, the sum of the weight of the lifeboat, Class C boat or other boat, its full equipment, the blocks and falls, and a launching crew consisting of two persons, the weight of each person being taken to be 75 kilogrammes;
  - 1.3 in relation to winches, the maximum pull exerted by the fall or falls at the winch drum during lowering, hoisting or stowing which in any case is to be taken as not less than the working load on the davit or davits divided by the velocity ratio at the lowering tackle.

#### PART 2 – CONSTRUCTION

##### *Strength*

- 1.1 Every davit serving a lifeboat which is required to be put into the water when loaded with its total complement of persons shall, together with its winch, falls, blocks and all other associated lowering gear, be of such strength that the lifeboat with its full equipment and manned by a launching crew of not less than two persons can be turned out and then safely lowered into the water from the embarkation position with its total complement of persons, when the ship has a trim of up to 10 degrees and is listed up to 15 degrees either way.
- 1.2 Every mechanically controlled single-arm davit shall, together with its winch, falls, blocks and all other associated lowering gear, be of such strength and the operating gear shall be of such power that the lifeboat when fully equipped and manned with a launching crew of two members can be turned out and then safely lowered into the water with the ship listed to 25 degrees.
- 1.3 Every set of davits, davit or other means of launching to which a lifeboat, Class C boat or other boat is attached, other than a davit the strength of which is specified in paragraph 1.1 or 1.2, shall, together with its winch, falls, blocks and all other associated lowering gear, be of such strength that the lifeboat, Class C boat or other boat with its full equipment and manned by a launching crew of two members, can be turned out and then safely lowered into the water when the ship has a trim of 10 degrees and is listed up to 15 degrees either way.
- 1.4 Every set of davits, davit or other means of launching to which a lifeboat, Class C boat or other boat is attached, together with its winch and associated hoisting gear shall be of such strength that the boat can be safely hoisted and stowed when loaded with its full equipment and at least two persons. In the case of an emergency lifeboat, it shall be safely hoisted from the water to the embarkation deck at a speed of not less than 0.3 metres per second when loaded with its full equipment and distributed load of 1000 kilogrammes.

### *Gravity davits*

2.1 All gravity davits shall be so designed that there is a positive turning-out moment during the whole of the davit travel from the inboard to the outboard position when the vessel is upright and also when the vessel is listed at any angle up to and including 25 degrees either way from upright.

2.2 In the case of gravity davits comprising arms mounted on rollers which engage with and travel down fixed inclined trackways, the trackways shall be inclined at an angle of not less than 30 degrees to the horizontal when the vessel is upright.

### *Luffing davits*

3. The operating gear of luffing davits shall be of sufficient power to ensure that lifeboats, Class C boats or other boats fully equipped and manned with their launching crew, can be turned out against a list of at least 15 degrees.

### *Mechanically controlled single-arm davits*

4. The working load of any mechanically controlled single-arm davit shall not exceed 1525 kilogrammes.

### *Stresses*

5.1 In the case of davits other than mechanically-controlled single-arm davits the designed stress on the davit arms when operating under maximum load and conditions of trim and list, shall include an adequate factor of safety having regard to the quality of the material used, the method of construction and the live nature of the load to which the davits are subjected.

5.2 In the case of mechanically-controlled single-arm davits the designed stress on the davit when operating under maximum load and conditions of favourable list shall include an adequate factor of safety having regard to the quality of the material used, the method of construction and the live nature of the load to which the davit is subjected.

### *Static load test*

6. Each davit with its arm at full outreach shall be capable of withstanding a static load test of not less than 2.2 times that part of the working load supported by the arm.

### *Attachments at the davit head*

7. The attachments at the davit head from which the blocks are suspended shall be capable of withstanding a proof load test of not less than 2.2 times the maximum load on the attachments.

### *Blocks*

8.1 All blocks used in the operation of hoisting and lowering of lifeboats, Class C boats or other boats shall be of a design that includes an adequate factor of safety. Lower blocks, when fitted, shall be non-toppling and, in the case of emergency lifeboats, the design shall prevent the falls from cabling. The size of blocks shall be commensurate with the size of the falls.

8.2 A metal block shall be capable of withstanding a proof load test of not less than 2.2 times the maximum load it is intended to carry in service. The clearance between the sheaves and the block cheeks of metal blocks in which wire rope is used shall be kept to a practical minimum which will prevent the rope from overriding the rim of the sheave of any block or lead sheave. Component parts of blocks other than their sheaves shall be of ductile material.

**8.3** A wood block shall be capable of withstanding a proof load of not less than 2.2 times the load on the block. The width between the cheeks shall be 12 millimetres greater than the diameter of new cordage ropes when those ropes are 30 millimetres diameter; and this width is to be reduced in proportion to the diameter of the ropes when they are less than 30 millimetres in diameter.

### *Wire ropes*

**9.1** The breaking tensile load of each wire rope used for lowering lifeboats, Class C boats or other boats shall not be less than six times the maximum load on the wire rope when lowering, hoisting or stowing.

**9.2** Wire ropes shall be securely attached to the drum of the winch, and the end attachments. The wires and other parts from which the lifeboat, Class C boat or other boat are to be suspended shall be capable of withstanding a proof load of not less than 2.2 times the maximum load to be imposed upon them in service.

**9.3** Where wire rope splices or ferrule-secured eye terminals are used they shall be capable of withstanding a proof test of not less than 2.2 times the load imposed on them in service: except that this test is not required if samples representing each size of wire show a factor of safety of at least 5 when tested to destruction.

### *Winches*

**10.1** In the case of davits, other than mechanically-controlled single-arm davits, winch drums shall be arranged to keep the two falls separate and to enable them to pay out at the same rate. The leads of the wire ropes shall be such that they will wind evenly on the drums and lead blocks shall be arranged to give a fleet angle or angle of lead of not more than five degrees for grooved drums and three degrees for ungrooved drums. In the case of mechanically-controlled single-arm davits, the lead of the wire rope fall shall be such that the fall winds evenly on the drum.

**10.2** Winch brakes shall be of robust construction and provide complete control of speed in the operation of lowering. The hand brake shall be so arranged that it is normally in the "ON" position and returns to the "ON" position when the control handle is not being operated. The weight on the brake lever shall be sufficient to operate the brake effectively without additional pressure. The brake gear shall automatically control the speed of lowering to ensure that the lifeboat, Class C boat or other boat is lowered expeditiously but consistent with safety. For this purpose, the automatic brake shall be set to give a speed of lowering of between 0.3 and 0.6 metres per second. Ratchet gear shall be incorporated in the hand brake mechanism of lifeboat winches. Where practicable the brake gear shall be so situated as to enable the operator to observe the lifeboat, Class C boat or other boat during the whole process of it being launched into the water, provided that winches serving emergency lifeboats shall in any case be so placed.

**10.3** Each winch shall be capable of lowering and holding a test load of 1.5 times the working load as defined in subparagraph 1.1.4 of Part 1.

**10.4** Winches shall be so constructed that the crank handle or handles are not rotated by moving parts of the winch when the lifeboat Class C boat or other boat is being lowered or when it is being hoisted by power and provision shall be made to allow the falls to be manually unwound.

### *Cordage ropefalls*

11. Cordage ropefalls shall be of manila or some other suitable material and shall be durable, unkinkable, firm laid and pliable. They shall be able to pass freely under any conditions through a hole 10 millimetres larger than the nominal diameter of the rope. The breaking load of each rope used for lowering lifeboats, Class C boats or other boats shall be not less than 6 times the maximum load on the rope when lowering or hoisting. Rope of less than 20 millimetres in diameter shall not be used for lifeboat falls. Winding reels or flaking boxes for the manila rope falls shall be provided.

### *Bollards*

12. Suitable bollards or other equally effective appliances for lowering any lifeboat, Class C boat or other boat shall be provided in all cases where cordage rope falls are used. Such bollards or other appliances shall be sited so as to ensure that the lifeboat, Class C boat or other boat served by them can be safely lowered, and fairleads or lead sheaves shall be fitted so as to ensure that it shall not be lifted during the process of turning out or swinging out.

## **PART 3 – TESTS AFTER INSTALLATION ON BOARD**

### *General*

1. Tests shall ensure that all lifeboats, Class C boats or other boats attached to davits and loaded with the required equipment can be re-stowed safely from the embarkation position. And, when so loaded, the life boat, Class C boat or other boat can be lowered by gravity into the water against the frictional resistance of the winch, falls, blocks and other associated gear.

### *Lowering tests*

2.1 Each pair of davits to which paragraph 1.1 of Part 2 applies and their associated lifeboat winches and brakes shall be capable of lowering the lifeboat from the embarkation deck into the water with its equipment and a distributed weight equal to the total number of persons which it is permitted to accommodate plus 10 per cent of the working load. Winch brakes exposed to the weather shall be capable of withstanding this test with the braking surface wetted.

2.2 In the case of davits to which paragraph 1.2 or 1.3 of Part 2 applies, the lifeboat, Class C boat or other boat shall be lowered into the water with its equipment and a distributed weight equal to the weight of a launching crew of two persons plus 10 per cent of the working load.

2.3 For the purpose of the tests required under paragraphs 2.1 and 2.2, the weight of a person shall be taken to be 75 kilogrammes.

### *Hoisting tests for emergency lifeboats*

3. Emergency lifeboats which are required to be served by winches for recovery shall, in addition to the tests required in paragraphs 2.1 and 2.2, be tested by hoisting the emergency lifeboat with its equipment and a distributed load of 1000 kilogrammes plus 10 per cent of the total hoisting load, including blocks and falls, from the water to the embarkation deck at the maximum hoisting speed.

## SCHEDULE 11

### LAUNCHING DEVICES FOR INFLATED BOATS

1. In this Schedule the expression “working load” means the total weight of the inflated boat, its full equipment, the blocks and falls, a launching crew of 2 persons each weighing 75 kilogrammes and a weight of 60 kilogrammes or the weight of the engine together with its fuel tank and sufficient fuel for three hours operation, whichever is the greater.
2. Every device shall be designed so that when loaded with the working load as defined in paragraph 1 there will be an adequate factor of safety both when the ship is upright and when the ship has a trim of 10 degrees towards the side on which the device is fitted and is listed 15 degrees.
3. Every such appliance shall be tested to a static load of 2.2 times the working load.
4. Blocks provided with every such device shall be proof-tested to 2.2 times the working load, and the falls shall have a factor of safety of at least 6.
5. Every such device shall be –
  - 5.1 capable of recovering the inflated boat and bringing it on board the ship;
  - 5.2 readily available and not stowed or used for any other purpose other than the launching of liferafts whilst the ship is at sea;
  - 5.3 provided with suitable means for manual operation; and
  - 5.4 satisfactorily tested after installation.
6. Every such device shall be provided with a winch when the inflated boat is situated more than 4.5 metres above the lightest sea-going waterline. The winch shall be adequate for the lowering operation and shall be tested to 1.5 times the working load. The brake gear of the winch shall include means for automatically maintaining the lowering speed between 0.3 metres per second and 0.6 metres per second.

## SCHEDULE 12

PART 1 – PROVISION OF EQUIPMENT AND RATIONS IN  
LIFEBOATS, BOATS AND LIFERAFTS*General*

- 1.1 No motor lifeboat or mechanically-propelled lifeboat shall be required to carry a mast or sails nor more than half the complement of oars. Every such lifeboat shall carry two boat hooks.
- 1.2 Every motor lifeboat shall carry at least two portable fire extinguishers capable of discharging foam or other substance suitable for extinguishing oil fires, a receptacle containing a sufficient quantity of sand and a scoop for distributing the sand. The portable fire extinguishers shall be of a type complying with the requirements of regulation 69 of the Merchant Shipping (Fire Protection: Large Ship) Regulations 1998(a) except that the capacity of each extinguisher shall not be required to exceed 4.5 litres of fluid or its equivalent.
- 1.3 The equipment provided in a lifeboat, Class C boat, inflated boat or other boat, with the exception of the boat hook, which shall be kept free for fending off purposes, shall be suitably secured within the lifeboat or boat. Any lashing shall ensure the security of the equipment and not interfere with the lifting hooks or prevent ready embarkation. All items of equipment shall be as small and as light in weight as possible and shall be packed in suitable and compact form.
- 1.4 All the rations provided in a lifeboat shall be stowed in watertight tanks, which shall be firmly secured to the lifeboat.
- 1.5 The tanks for the food and water rations shall be conspicuously marked “food” or “water” whichever is appropriate.

*Ships of Classes I, VII, VII(A) and VII(T)*

- 2.1 The equipment of every lifeboat carried in ships of Classes I, VII, VII(A) and VII(T) shall be as follows –
- 2.1.1 a single-banked complement of buoyant oars, two spare buoyant oars and a buoyant steering oar; one set-and-a-half of crutches attached to the lifeboat by lanyard or chain; a boat hook;
- 2.1.2 two plugs for each plug hole (except where automatic valves are fitted) attached to the lifeboat by lanyards or chains; a bailer and two buckets;
- 2.1.3 a rudder attached to the lifeboat and a tiller;
- 2.1.4 a lifeline becketed round the outside of the lifeboat, means to enable persons to cling to the lifeboat if upturned in the form of bilge keels or keel rails, together with grab lines secured from gunwale to gunwale under the keel;
- 2.1.5 a locker conspicuously marked as such, suitable for the stowage of small items of equipment;
- 2.1.6 two hatchets, one at each end of the lifeboat;
- 2.1.7 a lamp with oil sufficient for 12 hours;

---

(a) S.I. 1998/1012.

- 2.1.8** a watertight box containing two boxes of matches not readily extinguished by wind;
- 2.1.9** a mast or masts, with galvanised wire stays together with orange-coloured sails which shall be marked for identification purposes with the first and last letter of the name of the ship to which the lifeboat belongs;
- 2.1.10** a compass in a binnacle;
- 2.1.11** a sea anchor;
- 2.1.12** two painters of sufficient length and size. One shall be secured to the forward end of the lifeboat with strop and toggle so that it can be released and the other shall be firmly secured to the stem of the lifeboat and be ready for use;
- 2.1.13** a container with 4.5 litres of vegetable, fish or animal oil. Means shall be provided to enable the oil to be easily distributed on the water and so arranged that it can be attached to the sea anchor;
- 2.1.14** four rocket parachute flares and six hand flares complying with the requirements of Parts 2 and 3 of Schedule 7 in Merchant Shipping Notice MSN 1676 (M) and packed in a watertight container;
- 2.1.15** two buoyant smoke signals complying with Part 4 of Schedule 7 in Merchant Shipping Notice MSN 1676 (M) packed in a watertight container;
- 2.1.16**
- 2.1.16.1** a first aid outfit complying with Part 1 of Schedule 13 in Merchant Shipping Notice MSN 1676 (M); and
- 2.1.16.2** six anti-seasickness tablets for each person which the boat is permitted to accommodate;
- 2.1.17** a waterproof electric torch suitable for Morse signalling together with a spare set of batteries and a spare bulb in a waterproof container;
- 2.1.18** a daylight-signalling mirror;
- 2.1.19** a jack-knife fitted with a tin opener to be kept attached to the lifeboat with a lanyard;
- 2.1.20** two light, buoyant heaving lines;
- 2.1.21** a manual pump complying with the requirements of Part 5 of Schedule 1;
- 2.1.22** a whistle;
- 2.1.23** a fishing line and six hooks;
- 2.1.24** a cover of a highly visible colour capable of protecting the occupants from exposure;
- 2.1.25** a copy of the Department of Transport's Rescue Signal Table published by Her Majesty's Stationery Office;
- 2.1.26** means to enable persons in the water to climb into the lifeboat; and
- 2.1.27** except for lifeboats in ships of Class I, thermal protective aids sufficient for 10 per cent of the number of persons the lifeboat is permitted to accommodate, or for two persons, whichever is the greater number.

*Ships of Classes II, II(A), VIII(T), VIII(A), VIII(A)(T) and IX and ships of Class XI which do not proceed outside the Limited European Trading Area.*

3. The equipment of every lifeboat carried in ships of these Classes shall be in accordance with the requirements of paragraph 2.1, except that such lifeboats shall not be required to carry the equipment specified in subparagraphs 2.1.9, 2.1.18, 2.1.23 and 2.1.27. Lifeboats in ships of Classes II and II(A) shall not be required to carry equipment specified in subparagraph 2.1.17.

("Limited European Trading Area" means "an area bounded by a line from a point on the Norwegian coast in latitude 62° North to a point 62° North 02° West; thence to a point 58° North 10° West; thence to a point 54° North 14° West; thence to a point 51° North 14° West; thence to a point 38° 40' North 10° West; thence to Cape St Vincent; but excluding all waters which lie to the northward and eastward of a line between Kalmar on the East coast of Sweden and a point on the West coast of Oland in latitude 56° 40' North and from the southern tip of Oland to Gdansk, except between the dates of 1st May and 30th November when the remaining waters of the Baltic Sea are included.)

*Ships of Classes IX(A) and IX(A)(T)*

4.1 The equipment of every boat carried in ships of Classes IX(A) and IX(A)(T) shall be as follows –

- 4.1.1 a single banked complement of buoyant oars and a buoyant steering oar; one set of crutches attached to the boat by lanyard or chain; a boat hook;
- 4.1.2 two plugs for each plug hole;
- 4.1.3 a bailer;
- 4.1.4 a rudder attached to the boat, and a tiller;
- 4.1.5 a lifeline becketed round the outside of the boat; and
- 4.1.6 a painter of sufficient length and size.

*Ships of Class XI*

5.1 The equipment of every boat carried in a ship of this Class shall be as follows –

- 5.1.1 a single-banked complement of buoyant oars and a buoyant steering oar; one set of crutches attached to the boat by lanyard or chain; a boat hook;
- 5.1.2 two plugs for each plug hole;
- 5.1.3 a bailer;
- 5.1.4 a rudder attached to the boat and a tiller;
- 5.1.5 a lifeline becketed round the outside of the boat;
- 5.1.6 a painter of sufficient length and size;
- 5.1.7 a sea anchor; and
- 5.1.8 a hatchet.

*Ships of Classes XI and XII and Class C Boats*

**6.1** The equipment of every lifeboat or Class C boat carried in ships of these Classes or on all Class C boats shall be equipped as follows –

- 6.1.1** A single-banked complement of buoyant oars and one spare buoyant oar: provided that there shall never be less than three oars; one set of crutches attached to the boat by lanyard or chain; a boat hook;
- 6.1.2** two plugs for each plug hole (except where automatic valves are fitted) attached to the boat by lanyards or chains; a bailer and a bucket;
- 6.1.3** a rudder attached to the boat, and a tiller;
- 6.1.4** a lifeline becketed round the outside of the boat;
- 6.1.5** a locker, conspicuously marked as such, suitable for the stowage of small items of equipment;
- 6.1.6** a painter of sufficient length and size secured to the forward end of the boat with strop and toggle so that it can be released;
- 6.1.7** means to enable persons to cling to the boat if upturned, in the form of bilge keels or keel rails;
- 6.1.8** a waterproof electric torch suitable for Morse signalling, together with a spare set of batteries and a spare bulb in a waterproof container;
- 6.1.9** two light, buoyant heaving lines;
- 6.1.10** a hatchet;
- 6.1.11** 6 distress flares complying with Part 3 of Schedule 7 in Merchant Shipping Notice MSN 1676 (M);
- 6.1.12** 2 buoyant smoke signals complying with Part 4 of Schedule 7 in Merchant Shipping Notice MSN 1676 (M); and
- 6.1.13** thermal protective aids sufficient for 10 per cent of the number of persons the lifeboat is permitted to accommodate, or for two persons, whichever is the greater number.

Schedule 4

**PART 2 – EQUIPMENT FOR INFLATED BOATS**

*Ships of Classes IX(A) and IX(A)(T)*

**1.1** The equipment for every inflated boat carried in a ship of these Classes shall be as follows –

- 1.1.1** at least two buoyant oars and two buoyant paddles;
- 1.1.2** a bailer and two sponges;
- 1.1.3** a crutch or steering grommet on the transom;
- 1.1.4** a grab line secured round the outside of the boat and a grab line fitted round the inside of the boat;

- 1.1.5 a painter of adequate size and length;
- 1.1.6 hand holds or straps for the purpose of righting the boat from the inverted position;
- 1.1.7 an efficient manually-operated bellows or pump;
- 1.1.8 bridle-slinging arrangements to allow the boat to be lowered into or raised from the water complying with the requirements of Part 2 of Schedule 4; and
- 1.1.9 a repair kit in a suitable container for repairing punctures in the buoyancy compartments.

### *Inflated Boats*

- 2.1 Every inflated boat shall be equipped as follows –
  - 2.1.1 at least two buoyant oars and two buoyant paddles;
  - 2.1.2 a bailer and two sponges;
  - 2.1.3 a crutch or steering grommet on the transom;
  - 2.1.4 a grab line secured round the outside of the boat and a grab line fitted round the inside of the boat;
  - 2.1.5 a painter of adequate size and length;
  - 2.1.6 hand holds or straps for the purpose of righting the boat from the inverted position;
  - 2.1.7 an efficient manually-operated bellows or pump;
  - 2.1.8 bridle-slinging arrangements to allow the boat to be lowered into or raised from the water complying with the requirements of Part 2 of Schedule 4;
  - 2.1.9 a repair kit in a suitable container for repairing punctures in the buoyancy compartments;
  - 2.1.10 a sea anchor capable of preventing the loaded boat drifting at more than one knot in a wind of force 5 or 6, attached to the boat by a line of adequate strength at least 9.0 metres in length;
  - 2.1.11 a safety knife;
  - 2.1.12 two buoyant rescue quoits attached to 18.0 metres of light, buoyant line;
  - 2.1.13 a waterproof electric torch suitable for Morse signalling together with spare set of batteries and a spare bulb in a waterproof container; and
  - 2.1.14 a container or pocket for loose equipment.

## **PART 3 – RATIONS FOR LIFEBOATS**

### *Food*

- 1. Every lifeboat carried in a ship of Classes I, VII, VII(A), VII(T) and Class XI shall be provided with a food ration totalling not less than 10,000 kiloJoules for each person it is permitted to accommodate. Such ration shall not be required on ships which do not make voyages outside the Limited European Area.

## *Freshwater*

**2.1** Every lifeboat carried in a ship of Class I, II, II(A), VII, VII(A),VII(T), VIII, VIII(T), VIII(A), VIII(A)(T), IX and XI shall be provided with at least 3 litres of fresh water for each person whom it is permitted to accommodate, or at least 2 litres of fresh water for each such person, together with a de-salting apparatus capable of providing at least 1 litre of drinking water for each such person and in either case the total quantity of water shall be increased as far as is practicable: provided that this paragraph shall not apply to any lifeboat which is carried as an alternative to a Class C boat in a ship of Class VII, VII(T), VII(A), VIII, VIII(T), VIII(A), VIII(A)(T), IX or XI.

**2.2** The water shall be kept in the lifeboat in suitable containers and there shall be provided at least one rust-proof dipper, which shall be attached to the containers by a lanyard, and three rust-proof drinking vessels (one graduated in 10, 20 and 50 cubic centimetres), provided that a container of less than 2 litre capacity shall not be required to be provided with a dipper. The water shall be frequently changed so as to ensure that it is always clean and fit for drinking.

Other Ships Regulations  
reg 7(6), 8(5), and 11(6)

## **PART 4 – SPECIAL EQUIPMENT FOR CERTAIN MOTOR LIFEBOATS**

### *Searchlights*

**1.** In every ship of Classes I, II and VII(A) the motor lifeboats shall be provided with a searchlight which shall include a lamp of at least 80 watts, an efficient reflector and a source of power which will give effective illumination of a light-coloured object having a width of about 18 metres at a distance of 180 metres for a total period of six hours. The search light shall be capable of working for at least three hours continuously.

Schedule 5

## **PART 5 – EQUIPMENT AND RATIONS FOR LIFERAFTS**

**1.** The equipment and rations provided in every liferaft shall be as follows –

- 1.1** one buoyant rescue quoit, attached to at least 30 metres of buoyant line;
- 1.2** for liferafts which are permitted to accommodate not more than 12 persons, one safety knife and one bailer; for liferafts which are permitted to accommodate 13 persons or more, two safety knives and two bailers;
- 1.3** two sponges;
- 1.4** two sea anchors, one permanently attached to the liferaft and one spare with line;
- 1.5** two paddles;
- 1.6** one repair outfit capable of repairing punctures in buoyancy compartments unless the liferaft complies with the requirements of Part 2 of Schedule 5;
- 1.7** one topping-up pump or bellows, unless the liferaft complies with Part 2 of Schedule 5;
- 1.8** three safety tin openers;
- 1.9** a first aid outfit complying with the requirements of Part 1 of Schedule 13 in Merchant Shipping Notice MSN 1676 (M);
- 1.10** one rust-proof drinking vessel, graduated in 10, 20 and 50 cubic centimetres;

- 1.11 one waterproof electric torch suitable for Morse signalling together with a spare set of batteries and a spare bulb in a waterproof container;
- 1.12 one daylight-signalling mirror and one signalling whistle;
- 1.13 two rocket parachute flares complying with the requirements of Part 2 of Schedule 7 in Merchant Shipping Notice MSN 1676 (M);
- 1.14 six hand flares complying with the requirements of Part 3 of Schedule 7 in Merchant Shipping Notice MSN 1676 (M);
- 1.15 one fishing line and six hooks;
- 1.16 a food ration complying with the requirements of Part 2 of Schedule 13 in Merchant Shipping Notice MSN 1676 (M), totalling not less than 10,000 kiloJoules for each person the liferaft is permitted to accommodate; these rations shall be in airtight packaging and be stowed in a watertight container.
- 1.17 watertight receptacles containing 1.5 litres of fresh water for each person the liferaft is permitted to accommodate, of which 1 litre per person may be replaced by a suitable de-salting apparatus capable of producing an equal amount of fresh water;
- 1.18 six anti-seasickness tablets for each person which the liferaft is permitted to accommodate;
- 1.19 instructions printed in English on how to survive in the liferaft;
- 1.20 one copy of the Department of Transport's Rescue Signal Table published by Her Majesty's Stationery Office; and
- 1.21 thermal protective aids sufficient for 10 per cent of the number of persons the liferaft is permitted to accommodate or for two persons, whichever is the greater number.

2. In ships of Class I such liferafts shall not be required to carry the equipment specified in paragraph 1.20 above.

3. In ships of Classes II and II(A), one or more liferafts, not being less than one-sixth of the number of liferafts carried in any such ship, shall be provided with the equipment specified in paragraphs 1.1 to 1.7 inclusive, 1.11, 1.19 and 1.20, and with one-half of the equipment specified in paragraphs 1.13 and 1.14. The remainder of the liferafts carried shall be provided with the equipment specified in paragraphs 1.1 to 1.7 inclusive, 1.19 and 1.20 of the said paragraph.

4. In ships of Classes IX(A) and IX(A)(T) liferafts shall be provided with the equipment specified in paragraphs 1.1, 1.2, 1.3, 1.5, 1.6, 1.7, 1.19 and 1.20 together with one sea anchor which shall be permanently attached to the liferaft.

5. In ships of Class XII of less than 21.3 metres in length liferafts shall be provided with the equipment specified in paragraphs 1.1, 1.2, 1.3, 1.5, 1.6, 1.7, 1.9, 1.10, 1.11, 1.13, 1.18, 1.19 and 1.20 together with the following equipment –

- 5.1 one sea anchor which shall be permanently attached to the liferaft;
- 5.2 two safety tin-openers;
- 5.3 three hand flares complying with the requirements of Part 3 of Schedule 7 in Merchant Shipping Notice MSN 1676 (M); and
- 5.4 watertight receptacles containing half a litre of fresh water for each person which the liferaft is permitted to accommodate.

MSPP2  
Maritime and Coastguard Agency  
Spring Place  
105 Commercial Road  
Southampton SO15 1EG

Tel 01703 329184  
Fax 01703 329204

August 1999

MS 10/19/16

© Crown Copyright 1999



*An executive agency of the Department of the  
Environment, Transport and the Regions*



---

## **Guidelines for Training Crews for the Purpose of Launching Lifeboats and Rescue Boats from Ships Making Headway through the Water**

Notice to Shipowners and Masters

*This Notice supersedes Merchant Shipping Notice No. M.1218*

---

### *Summary*

This Merchant Shipping Notice is an integral part of the Merchant Shipping (Musters, Training and Decision Support System) Regulations 1999. It supersedes Merchant Shipping Notice No. M.1218 providing guidelines for training crews launching lifeboats and rescue boats from ships making headway through the water in accordance with regulation 6 of these Regulations.

1. The Merchant Shipping (Life-Saving Appliances) Regulations require lifeboats (the keels of which were laid on or after 1st July 1986) carried on cargo ships of 20,000 GRT and upwards, and all rescue boats to be capable of being launched when the ship on which they are carried is making headway at speeds up to 5 knots in calm water.

2. There is no requirement that lifeboat and rescue boat launching drills be carried out when a ship is making headway but regulation 10(8) of the Merchant Shipping (Musters, Training and Decision Support System) Regulations 1999 requires that if such drills are conducted, they must be conducted in accordance with the guidance specified in this Notice. This guidance, which has been developed by the International Maritime Organization on account of the potential hazards involved, consists of guidelines set out in the Annex to this Notice.

3. Such drills should not be carried out with boats other than those described in paragraph 2 of the Annex except where it has been determined by experience that the boats, release gear and launching arrangements are suitable for the

purpose, the boat crews have been fully trained, and the drills are carried out in accordance with well proven procedures.

MSPP2(C)  
Maritime and Coastguard Agency  
Spring Place  
105 Commercial Road  
Southampton SO151EG

Tel: 01703 329184

Fax: 01703 329204

July 1999

MS 70/17/0004

© Crown Copyright 1999



*An executive agency of the Department of the Environment, Transport and the Regions*

GUIDELINES FOR TRAINING CREWS FOR THE  
PURPOSE OF LAUNCHING LIFEBOATS AND RESCUE BOATS  
FROM SHIPS MAKING HEADWAY THROUGH THE WATER

1. There is no requirement in the Merchant Shipping (Musters, Training and Decision Support System) Regulations 1999 to carry out training in launching lifeboats and rescue boats from ships making headway through the water. However these guidelines should be followed if such training is undertaken.
2. These guidelines apply to those launching drills undertaken with lifeboats and rescue boats capable of being safely launched with the ship making headway at speeds of up to 5 knots in calm water, and any other ship fitted with a lifeboat or rescue boat or both having on-load release gear adequately protected against accidental or premature use.
3. These guidelines supplement the procedures to be followed for the particular equipment provided on board a ship and as described in the instructions and information found in the ship's training manual required by the Merchant Shipping (Life-Saving Appliances for Ships Other than Ships of Classes III to VI(A)) Regulations 1999. This will include instructions on launching and recovery, the use of the release gear, clearing the boat from the ship, and where applicable, the use of a painter. The boat's crew should be instructed in the procedures to be followed before the drill commences.
4. Drills should either be carried out on board a ship at anchor or alongside where there is a suitable relative movement between ship and water or at a suitable shore establishment where similar conditions prevail. Alternatively, at the master's discretion, it may be carried out on board a ship when making headway in sheltered waters. For safety purposes, it is not necessary when training to exercise at the maximum design 5 knots headway launching capability of the equipment. Drills should be carried out with a low relative water speed particularly where inexperienced personnel are involved. When planning the drill consideration should be given to ensuring that, as far as practicable, the relative water speed will be at a minimum when recovering the boat.
5. None of the provisions in these guidelines are intended to inhibit launching drills carried out on ships where such drills are carried out on a frequent and regular basis with fully trained and experienced boat crews.
6. When planning for and carrying out launching drills the following precautions should be taken -
  - (a) drills should only be carried out under the supervision of an officer experienced in such drills and under calm water and clear conditions;
  - (b) provisions should be made for rendering assistance to the boat to be used in the drill in the event of unforeseen circumstances, for example, where practicable a second boat should be made ready for launching;
  - (c) when practicable the drill should be carried out when the ship has minimal freeboard;
  - (d) instructions as to procedures should be given to the boat's crew by the officer in charge before the drill commences;
  - (e) the minimum number of crew members should be in the boat compatible with the training to be carried out;
  - (f) lifejackets, and where appropriate, immersion suits should be worn;

- (g) except in the case of totally enclosed boats head protection should be worn;
- (h) for the purposes of the drill, skates where fitted should be removed unless they are designed to be retained under all launch conditions;
- (i) in the case of totally enclosed boats, all openings should be closed except for the helmsman's hatch which may be open to provide a better view for launching;
- (j) two-way radiotelephone communications should be established between the officer in charge of lowering, the bridge and the boat before lowering commences, and be maintained throughout the exercise;
- (k) during lowering and recovery and while the boat is close to the ship, steps should be taken to ensure that the ship's propeller is not turning, if practicable;
- (l) before the boat enters the water the boat's engine should be running; and
- (m) the launching and recovery should be followed by a debriefing session to consolidate the lessons learned.



---

---

## **Arrangements for the Carriage of Agreed Search and Rescue Co-operation Plans Aboard UK Passenger Vessels**

This notice should be read by all Masters, Operators, Owners and other crew members of United Kingdom passenger vessels.

*This Notice replaces Merchant Shipping Notice MSN 1761 and should be read in conjunction with the Merchant Shipping (Safety of Navigation) Regulations 2002 - SI 2002 No.1473.*

---

---

### *Summary*

This notice provides details of the Search and Rescue (SAR) Co-operation Plan requirements under *The Merchant Shipping (Safety of Navigation) Regulations 2002*.

- A plan for co-operation with the appropriate SAR services must be drawn up and carried by all UK passenger vessels and all passenger vessels using United Kingdom waters.
- The plan must be agreed with the SAR service relevant to the vessel's area(s) of operation.
- Formats for the plan are included in Annexes B & C to this Merchant Shipping Notice.
- Plans compiled in accordance with MSN 1761 or its predecessors do NOT need to be changed because of the issue of this Merchant Shipping Notice. This Notice is issued primarily to update the information given in MSN 1761 as regards underlying legislation, IMO guidelines, and contact details for HM Coastguard offices administering the plans, and to provide some additional information and guidance.

### **INTRODUCTION**

1. The Merchant Shipping (Safety of Navigation) Regulations 2002 ("the Regulations") apply to UK passenger vessels and other passenger vessels in UK waters the SOLAS requirements regarding SAR co-operation which entered into force internationally on 1 July 1997. These provisions were amended with effect from 1 July 2002, so as to clarify their application to passenger vessels which transit many SAR Regions, such as cruise ships. The 2002 Regulations have replaced the Merchant Shipping (Co-operation with Search and Rescue Services) Regulations 1998, which originally applied the SOLAS provisions.
2. SOLAS requires the carriage of plans for co-operation between passenger vessels and relevant SAR services. This requirement resulted from the sinking of the ESTONIA, and other accidents involving passenger-carrying vessels. In the interests of safety and efficient

emergency response, the requirement applies to all UK passenger vessels.

### **SCOPE**

3. The Regulations apply to all classes of UK passenger vessel and other passenger vessels in UK waters. A classification of all ships affected is at [Annex A](#). For passenger vessels operating in inland or tidal waters, reference to the categorisation of waters in which they operate may be found in MSN 1776 or its successor.

### **REQUIREMENT**

4. The owner of a ship to which the Regulations apply shall ensure that a set of SAR co-operation plans have been agreed with the relevant SAR services, and that the plans are kept up-to-date.

### **SAR CO-OPERATION PLAN**

5. All UK passenger vessels and all passenger vessels in UK waters must have on board an agreed and up-to-date plan for co-operation with relevant SAR services in event of an emergency. The aim of the co-operation plan is to ensure that, in the event of an emergency, ships' staff, the members of a Company response team ashore, and SAR service staff are able to work efficiently together to resolve it. To this end, brief details of the passenger vessel, the Company, and the SAR service – including direct contact details – are exchanged and maintained ready for use.
6. A common approach is desirable. To facilitate this process frameworks for developing such a plan are appended to the IMO guidelines (Maritime Safety Committee Circular 1079) reproduced at [Annex B](#). These frameworks may be modified, with the agreement of the appropriate SAR service, according to the size of vessel concerned and its area(s) of operation. A simplified plan is available for the use of ships transiting many SAR Regions, such as cruise ships. An example of a very basic plan which may be suitable for a vessel in inland waters is also included at [Annex C](#).
7. To agree or amend a SAR co-operation plan, UK-based companies should

approach their nearest Coastguard co-ordination centre for advice on how to proceed. Contact details for these offices are contained in [Annex D](#). Vessels not operating within HM Coastguard's area of responsibility (HM Coastguard usually do not co-ordinate SAR in land-locked, non-tidal waters, for example) will be referred on to the appropriate authority in the vessel's operating area. Existing contingency or emergency plans already in place with the emergency services or Local Authorities and agreed to be satisfactory by all parties may be taken to have been prepared pursuant to these requirements.

### **EXERCISES**

8. The Regulations call for "periodic exercises" to test the plan's effectiveness. Where possible this requirement should be built into existing exercise programmes, so as to include the relevant SAR services and test co-operation arrangements without imposing an additional burden on ships' staff. For the larger companies an overall programme of exercises should be worked out by the Company and the relevant SAR service in conjunction, to ensure that, so far as possible, all staff are able to participate over time.
9. The IMO guidelines on periodic exercises are contained in paragraph 9 of [Annex B](#). As stated there, frequency and type of exercise depend on the circumstances in which the ship operates. For UK passenger vessels and passenger vessels in UK waters, the exercise requirements for this purpose are as follows.
10. UK passenger vessels of Class I, II, II(A) & III ([Annex A](#) refers) and similar vessels in UK waters are required to exercise annually with the relevant SAR services. These vessels are not required to exercise with more than one SAR service if, for example, they trade internationally. The principle of reciprocity applies. If a vessel has conducted a SAR co-ordination exercise within the last twelve months, she shall be deemed to have fulfilled the requirement. However, it is recommended that, over time, the vessel should exercise with each of the SAR services along her route(s).

11. Exercises may be of any type so long as the principle of co-operation is exercised and mutual understanding tested. Live, co-ordination, and tabletop exercises may all meet these criteria. 'Live' or 'full-scale' exercises involve the actual deployment of SAR facilities such as lifeboats and helicopters. 'Co-ordination' exercises involve key players – for example, the vessel's bridge team, the Company emergency response team ashore, and a Coastguard co-ordination centre –working through an emergency scenario on paper, without the actual deployment of SAR facilities. 'Tabletop' exercises involve key players meeting and working through an emergency scenario on paper in slow time, enabling discussion of the issues. 'Communications' exercises are simple tests of communications links – including telephone and telefax links – between vessel, Company and SAR service. Although useful for checking that contact details held are up-to-date, communications exercises are less useful than co-ordination exercises for improving mutual awareness, and the exercise requirement under these regulations should not be fulfilled by communications exercises alone. HM Coastguard can assist and will advise further as required.
12. UK passenger vessels of Classes IV, V, VI & VI(A) and similar vessels in UK waters are also recommended to exercise annually with the relevant SAR services. As an alternative, the fundamental principles of SAR co-operation – understanding of procedures and the maintenance of readily-accessible and up-to-date information – will be tested at annual survey.
11. Further advice is contained in [Annex B](#), paragraph 9.

Emergency Response Liaison Officer  
Directorate of Operations  
The Maritime and Coastguard Agency  
Bay 1/07, Spring Place  
105 Commercial Road  
SOUTHAMPTON  
SO15 1EG

Tel: 023 8032 9108  
Fax: 023 8032 9488

File Ref: CG 1/5/030

Published: 1 August 2004

© Crown Copyright 2004

*Safer Lives, Safer Ships, Cleaner Seas*

*Department for*  
**Transport**

The MCA is an executive agency  
of the Department for Transport

**UK CLASSIFICATION OF PASSENGER SHIPS**

- Class I - Passenger ships engaged on voyages any of which are long international voyages<sup>1</sup>.
- Class II - Passenger ships engaged on voyages (not being long international voyages) any of which are short international voyages<sup>2</sup>.
- Class II(A) - Passenger ships engaged on voyages of any kind other than international voyages, which are not ships of Classes III to VI(A) as defined in the Merchant Shipping (Passenger Ship Construction: Ships of Classes III to VI(A)) Regulations 1998.
- Class III - Passenger ships engaged only on voyages in the course of which they are at no time more than 70 miles by sea<sup>3</sup> from their point of departure and not more than 18 miles from the coast of the United Kingdom, and which are at sea only in favourable weather and during restricted periods<sup>4</sup>.
- Class IV - Passenger ships engaged only on voyages in Category A, B, C or D waters.
- Class V - Passenger ships engaged only on voyages in Category A, B or C waters.
- Class VI - Passenger ships engaged only on voyages with not more than 250 passengers on board, to sea, or in Category A, B, C or D waters, in all cases in favourable weather and during restricted periods, in the course of which the ships are at no time more than 15 miles, exclusive of any Category A, B, C or D waters, from their point of departure nor more than 3 miles from land.
- Class VI(A) - Passenger ships carrying not more than 50 passengers for a distance of not more than 6 miles on voyages to or from isolated communities on the islands or coast of the United Kingdom, and which do not proceed for a distance of more than 3 miles from land; subject to any conditions which the Secretary of State may impose.

---

<sup>1</sup> A 'long international voyage' is defined as being a voyage from a port in one country to which SOLAS applies to a port in another country or conversely; and which is not a short international voyage.

<sup>2</sup> A 'short international voyage' is defined as being an international voyage (i) in the course of which a ship is not more than two hundred nautical miles from a port or place in which passengers and crew could be placed in safety; and (ii) which does not exceed six hundred nautical miles in distance between the last port of call in the country in which the voyage begins and the first port of destination.

<sup>3</sup> For this purpose, 'sea' is defined as not including any waters of Category A, B, C or D.

<sup>4</sup> A 'restricted period' is defined as being a period which falls wholly within the following limits: (i) from the 1st April to 31st October, both dates inclusive; and (ii) between one hour before sunrise and one hour after sunset in the case of ships fitted with navigation lights conforming to the collision regulations and between sunrise and sunset in the case of any other ships.

## CATEGORISATION OF WATERS

MSN 1776 or its successor sets out the categorisations of waters in the UK and determines the waters not regarded as “sea” for the purposes of Merchant Shipping legislation:

Category A: Narrow rivers and canals where the depth of water is generally less than 1.5 metres.

Category B: Wider rivers and canals where the depth of water is generally more than 1.5 metres and where the significant wave height<sup>5</sup> could not be expected to exceed 0.6 metres at any time.

Category C: Tidal rivers and estuaries and large, deep lakes and lochs where the significant wave height could not be expected to exceed 1.2 metres at any time.

Category D: Tidal rivers and estuaries where the significant wave height could not be expected to exceed 2.0 metres at any time.

These categorisations should not be confused with waters classed under the EC Directive on Safety Rules and Standards for Domestic Passenger Ships.

## EC DOMESTIC PASSENGER SHIP CLASSIFICATION

Class A: a passenger ship engaged solely on domestic voyages<sup>6</sup> other than ships of Classes B, C and D.

Class B: a passenger ship engaged solely on domestic voyages in the course of which it is at no time more than 20 miles from the line of the coast where shipwrecked persons can land, corresponding to the medium tide height.

Class C: a passenger ship engaged solely on domestic voyages in sea areas where the probability of exceeding 2.5 metre significant wave height is less than 10% over a one year period for all year round operation, or over a specific restricted period of the year for operation exclusively in such period, in the course of which it is at no time more than 15 miles from a place of refuge, nor more than 5 miles from the line of the coast where shipwrecked persons can land, corresponding to the medium tide height.

Class D: a passenger ship engaged solely on domestic voyages in sea areas where the probability of exceeding 1.5 metre significant wave height is less than 10% over a one year period for all year round operation, or over a specific restricted period of the year for operation exclusively in such period, in the course of which they are at no time more than 6 miles from a place of refuge, nor more than 3 miles from the line of the coast where shipwrecked persons can land, corresponding to the medium tide height.

MSN 1747 sets out the geographical extent of EC sea areas ‘C’ and ‘D’ identified as applicable in waters around the UK.

---

<sup>5</sup> ‘Significant wave height’ is the mean height of the highest one third of wave heights.

<sup>6</sup> A ‘domestic voyage’ is defined as a voyage in the sea areas from a port of a Member State to the same or another port within that Member State.

The text of the International Maritime Organisation's Maritime Safety Committee Circular 1079 is reproduced below. While some of the Circular's provisions apply only to ships trading internationally, the general principles of SAR co-operation planning apply to passenger vessels of all kinds.

**GUIDELINES FOR PREPARING PLANS FOR CO-OPERATION BETWEEN  
SEARCH AND RESCUE SERVICES AND PASSENGER SHIPS  
(IN ACCORDANCE WITH SOLAS REGULATION V/7.3)**

**1 Introduction**

1.1 The purpose of these Guidelines is to provide a uniform basis for the establishment of plans for co-operation between passenger ships and SAR services in accordance with SOLAS regulation V/7.3. Co-operation plans developed in accordance with the Guidelines will meet the requirements of the regulation.

1.2 These Guidelines are applicable to all passenger ships to which SOLAS chapter I applies. They are relevant to the safety management system maintained by passenger ships in accordance with the International Safety Management (ISM) Code, and in particular to the section of the safety management system dealing with emergency preparedness. They may also be taken into consideration when drawing up SAR co-operation plans for passenger ships in the domestic trade.

**2 Aims & objectives of SAR co-operation planning**

2.1 The aim of SAR co-operation planning is to enhance mutual understanding between ship, company and SAR services so that, in the event of an emergency, all three parties will be able to work together efficiently. This is best achieved by the prior exchange of information, and by conducting joint emergency response exercises.

2.2 The objectives of SAR co-operation planning are:

.1 to link the SAR response plans of the company, the passenger ship, and relevant SAR services so that these plans complement each other;

.2 to enable the early and efficient establishment of contact in the event of emergency between the passenger ship, her operators' shore-based emergency response system, and the SAR services. The SAR co-operation plan should ensure that all relevant contact details are known to each of the three parties beforehand, and that these details are kept up-to-date;

.3 to provide the SAR services with easily accessible and up-to-date information about the ship – in particular her intended voyage and her communications and emergency response systems; and

.4 to provide the ship and her operators with easily accessible information about SAR and other emergency services available in the ship's area of operation, to assist in decision-making and contingency planning.

2.3 The co-operation plan is of use when a passenger ship suffers an emergency herself, or when she responds as a SAR facility, particularly when acting as On Scene Co-ordinator.

### 3 **The regulation**

3.1 The text of SOLAS V/7.3 is as follows:

“Passenger ships, to which chapter I applies, shall have on board a plan for co-operation with appropriate search and rescue services in event of an emergency. The plan shall be developed in co-operation between the ship, the company as defined in regulation IX/1, and the search and rescue services. The plan shall include provisions for periodic exercises to be undertaken to test its effectiveness. The plan shall be developed based on the guidelines developed by the Organisation.”

### 4 **General requirements**

4.1 The SAR co-operation plan does not replace more detailed emergency response plans already in place, whether as part of the company’s safety management system or the SAR services’ arrangements. But these plans should be linked so that the tripartite response to an emergency involving a passenger ship – ie, the response on-board, from the company’s emergency response organisation ashore, and from the SAR services – is co-ordinated effectively and efficiently. The SAR co-operation plan serves as that link.

4.2 The co-operation plan should contain the basic information which will enable the response to any emergency to commence without delay. This information will include direct contact details for the three parties – ship, company, and SAR services or SAR data provider<sup>7</sup> as described in paragraph 6.

4.3 Each of the parties to the co-operation plan should have access to a controlled copy<sup>8</sup> of it, so that each then knows what information is already available to the others.

4.4 Guidelines on testing the co-operation arrangements between ship, company, and SAR services are at paragraph 9 below.

### 5 **SAR co-operation plan frameworks**

5.1 The co-operation plan should be concise and user-friendly, so as to enable its easy use in emergency conditions. Depending on the type of trade the passenger ship is in, the co-operation plan should be drawn up according to the frameworks set out in Appendices 1 or 2 to these Guidelines. The frameworks and the SAR co-operation planning process are described in paragraphs 7 & 8 below, and are illustrated by flow diagrams at Appendix 3.

5.2 The use of common frameworks enables SAR service personnel to find the information they require rapidly, whatever ship or company they are dealing with. Likewise, ship’s crew members, or members of the company emergency response team ashore, are able to find the information they require, whatever the SAR region in which the emergency has occurred.

5.3 The frameworks are designed to enable modules of information (about different ships or SAR services, for example) to be easily added to the co-operation plan, or removed from it if no longer relevant, without the need for the whole co-operation plan to be revised.

---

<sup>7</sup> The ‘search and rescue data provider’ is defined in the International Aeronautical and Maritime Search and Rescue (IAMSAR) Manual as “a source for a rescue co-ordination centre to contact to obtain data to support search and rescue operations...” (Vol I, page xi).

<sup>8</sup> Document control, including controlled distribution of the copies of the plan held aboard the ship, by the company, and by the SAR services, is essential to ensuring that all copies are kept up-to-date.

## 6 Use by ships trading through many SAR regions

- 6.1 It will significantly enhance the effectiveness and efficiency of the response to an emergency if passenger ship crews and operators have developed a good mutual understanding with the SAR services available to them. This is as true for passenger ships which routinely transit many SAR regions as for any other passenger ship. Direct co-operation planning between ships, companies and local SAR services is encouraged wherever possible.
- 6.2 However, there are administrative difficulties in maintaining *direct* links between a ship transiting many SAR regions, such as some cruise ships, and each SAR service with which she might come into contact. For such ships it is not neither necessary to hold a copy of the ship's SAR co-operation plan at all the Rescue Co-ordination Centres (RCCs) whose regions she transits, nor to maintain on board extensive and up-to-date details of each and every SAR service.
- 6.3 The administrative difficulties can be overcome by use of the SAR data provider system, which permits the use of contact points between the global SAR service and cruise ship operators.
- 6.4 Under this system, the SAR data provider holds the ship's SAR co-operation plan on behalf of the SAR services. SAR services contact the SAR data provider to obtain the co-operation plan when it is required.
- 6.5 The company or ship should select a suitable SAR data provider. A shipping company, RCC, or other suitable entity may act as an SAR data provider. However, the ship cannot be her own SAR data provider, as this would negate the fundamental concept of easing the load on ship's staff during an emergency.
- 6.6 The SAR data provider must be able to provide essential information rapidly to the parties concerned. In order to achieve this, each SAR data provider should:
- .1 arrange for easy, continuous and immediate access to its SAR co-operation plans for relevant shipping companies and operators and for all RCCs with responsibilities in the operating areas of the ships concerned;
  - .2 ensure that essential technical capabilities, such as computers and communications links, are reliable and are redundant or have arrangements in place for rapid repair, and are provided with sources of emergency power. Establishing a back-up SAR data provider may satisfy this requirement;
  - .3 ensure that updates to plans are made promptly, and that back-up data in paper or electronic form is kept in a suitable safe location and is readily available;
  - .4 ensure that, if staff are necessary to provide data access to authorised users, such personnel are always available to handle urgent requests, trained to properly retrieve and transmit the needed information, and proficient in the use of the English language;
  - .5 ensure that pertinent information in the International SAR Co-operation Plans Index, including information on the primary and any back-up SAR data providers, is kept up-to-date. Details of the Index, and the procedure for updating it, are at paragraph 8 below.
- 6.7 SAR data providers should only release copies of co-operation plans to those parties named in the plans' controlled distribution lists – and to co-ordinating RCCs on request, in the event of emergency or for contingency planning purposes.
- 6.8 A passenger ship such as a ferry, which trades on fixed routes, should not use the SAR data provider system, but should compile a co-operation plan incorporating details of all the SAR

services along her route, in accordance with Appendix 1 of these Guidelines. Other passenger ships transiting many different SAR regions, perhaps on a seasonal basis, such as some cruise ships, may choose to use the SAR data provider system. Such ships are not required to include in the co-operation plan information beyond that set out in Appendix 2 to these Guidelines.

6.9 Flow diagrams summarising the SAR co-operation planning process in both cases are at Appendix 3.

6.10 Regardless of which system ships use, they are still encouraged to liaise as best they can with relevant SAR services. Direct communication, where practicable, will always be better than indirect.

## 7 **Administrative requirements for ships not using the SAR data provider system**

7.1 The procedure described in this paragraph is that for ships *not* using the SAR data provider system – that is, passenger ships on fixed routes, such as ferries. These ships and/or their operators will work with the relevant SAR services to complete and maintain a SAR co-operation plan drawn up in accordance with the framework set out in Appendix 1 of these Guidelines. The first flow diagram in Appendix 1 illustrates this process. The procedure for ships which *are* using the SAR data provider system is described in paragraph 8 below.

7.2 In order to compile a SAR co-operation plan in accordance with Appendix 1 of these Guidelines, the ship, or the company, should contact one of the SAR services responsible for the area in which the ship operates.

7.3 The ship or company and the SAR services each complete their own sections of the framework. The ship or company is responsible for providing the information in chapter 1 ‘The company’ and chapter 2 ‘The ship(s)’. The SAR services are responsible for providing the introductory paragraphs, chapter 3 ‘The RCCs’ and chapter 4 ‘SAR facilities’. It is recommended that neighbouring SAR services each hold copies of the others’ modules of information, so that the ship or company need only contact one SAR service in order to complete the whole co-operation plan.

7.4 Chapter 5 ‘Media relations’ and chapter 6 ‘Periodic exercises’ should be considered jointly. Chapter 5 is intended to contain brief details of how the company and the SAR services will co-ordinate their response to news media interest in any emergency and should include contact details for their respective press / public relations officers. The requirements of chapter 6 are considered in more detail at paragraph 9 below.

7.5 Copies of the completed co-operation plan should be distributed to each of the three parties to emergency response – the ship, the company, and the relevant SAR services. A controlled distribution system should be used to ensure that all parties maintain an up-to-date copy.

7.6 The co-operation plan should be written in:  
- the on-board working language(s) of the passenger ship; and  
- English and, if agreed, a language or languages commonly used by the ship, the company, and the SAR services.

The aim is that all those likely to need to refer to the co-operation plan should have a copy readily available in a language in which they are fluent. The co-operation plan may be provided and distributed electronically if agreed between the ship, the company and the SAR services.

7.7 SAR co-operation plans, once they have been agreed for a particular ship, should be recognised by the SAR services of all Administrations.

7.8 The originator of each module of the co-operation plan (the ship, company, or SAR service, as appropriate) is responsible for keeping it up-to-date and ensuring that all those holding controlled copies of the module are advised of changes. Each holder of a controlled copy of the co-operation plan is responsible for making and recording notified changes.

7.9 All parties should know where the controlled copies of the SAR co-operation plan are held. Each SAR co-operation plan should therefore contain a controlled distribution list, and each party to it should ensure that all relevant staff are aware of its existence, where it is stored, and how it may be used.

## 8 Administrative requirements for ships which are using the SAR data provider system

8.1 The procedure described in this paragraph is that for passenger ships that transit many SAR regions and choose to use the SAR data provider system. These ships and/or their operators will identify a SAR data provider (seeking advice from relevant SAR services as necessary) and will complete and maintain a SAR co-operation plan drawn up in accordance with the framework set out in Appendix 2 of these Guidelines. The second flow diagram in Appendix 3 illustrates this process. The procedure for ships *not* using the SAR data provider system is described in paragraph 7 above.

8.2 If the SAR data provider system is being used, the ship or company and the SAR data provider each complete their own sections of the framework, as appropriate. Chapter 4 'Media relations' and chapter 5 'Periodic exercises' should be considered jointly. Chapter 4 is intended to contain brief details of how the company will co-ordinate with the SAR services their response to news media interest in any emergency, and should include contact details of the company's press / public relations officers. The requirements of chapter 5 are considered in more detail at paragraph 9 below.

8.3 Controlled copies of the completed co-operation plan should be distributed by the company and be held by the ship, the company, and the SAR data provider. A controlled distribution system should be used to ensure that all parties maintain an up-to-date copy.

8.4 All parties should know where SAR data is held. Each copy of the plan should therefore contain a controlled distribution list, and each party to it should ensure that all relevant staff are aware of its existence, where it is stored, and how it may be used.

8.5 It is not essential that every RCC through whose SAR region the ship trades should hold a copy of the co-operation plan on file, only that each RCC should be able to obtain a copy from the relevant SAR data provider without delay. The SAR data provider holds copies of the co-operation plan for onward distribution to the co-ordinating RCC on request, in the event of an emergency or for contingency planning purposes.

8.6 Likewise it is not essential for the ship to carry details of each and every SAR region's resources, if the SAR data provider system is being used. However, the ship should always be able to obtain such details.

8.7 It is recommended that the ship carry on board details of the SAR services in regions in which she spends the majority of her time. But as a minimum, the ship should carry contact details for her SAR data provider, as set out in the framework at Appendix 2.

8.8 The co-operation plan should be written in:  
- the on-board working language(s) of the passenger ship; and  
- English and, if agreed, a language or languages commonly used by the ship, the company, and the SAR data provider.

The aim is that all those likely to need to refer to the co-operation plan should have a copy readily available in a language in which they are fluent. The co-operation plan may be

provided and distributed electronically if agreed between the ship, the company and the SAR data provider. The SAR data provider must maintain a copy of each co-operation plan in at least the English language, and must be able to transmit it immediately to the co-ordinating RCC on request, in the event of an emergency or for contingency planning purposes. Paragraph 6.5 above details the required capabilities of the SAR data provider in this context.

- 8.9 SAR co-operation plans, once they have been agreed for a particular ship, should be recognised by the SAR services of all Administrations.
- 8.10 The originator of each module of the co-operation plan (the ship, company, or the SAR data provider, as appropriate) is responsible for keeping it up-to-date and ensuring that all those holding controlled copies of the module are advised of changes. Each holder of a controlled copy of the co-operation plan is responsible for making and recording notified changes.
- 8.11 It is necessary to have a means of identifying who is acting as a particular ship's SAR data provider, to enable co-ordinating RCCs to obtain a copy of the co-operation plan on request, in the event of emergency or for contingency planning purposes.
- 8.12 The International SAR Co-operation Plans Index enables users to look up a ship by any of three means of identification (name, callsign or MMSI), and to identify who is that ship's SAR data provider and how to contact them. Information in the Index is deliberately limited: the co-operation plans themselves are the prime documents. Index entries are submitted, and kept up-to-date, by the SAR data provider.
- 8.13 Index entries, and any subsequent amendments, should be submitted by the SAR data provider to:

International SAR Co-operation Plans Index  
HM Coastguard  
Pendennis Point  
Castle Drive  
FALMOUTH TR11 4WZ  
UK

tel: +44 1326 211569  
fax: +44 1326 319264.

The telephone is staffed 0845 - 1700 local time, Monday to Friday.

Entries should be made for all passenger ships using the SAR data provider system in accordance with these Guidelines; ie, ships which trade through many SAR regions. Entries for other passenger ships trading internationally will also be accepted. Entries should include:

ship's name  
callsign  
MMSI  
company identity  
SAR data provider identity  
SAR data provider's 24-hour contact telephone number.

- 8.14 Entries received are added to the International SAR Co-operation Plans Index, which has been linked to the website of the United Kingdom's Maritime and Coastguard Agency at [www.mcga.gov.uk/c4mca/mcga-hmcg/mcga-sar\\_co-operation.htm](http://www.mcga.gov.uk/c4mca/mcga-hmcg/mcga-sar_co-operation.htm) (or follow the links 'HM Coastguard' and 'International SAR')<sup>9</sup>. Users with access to the internet are recommended to visit this website to obtain the details of a particular ship's SAR data provider. Instructions on use of the Index are included on the site. Users who do not have access to the internet are invited to contact MRCC Falmouth (24-hour telephone: +44 1326 317575) if a SAR co-operation plan is required in an emergency. MRCC Falmouth will then provide the caller with details of the relevant SAR data provider, and will be able to assist further if required.
- 8.15 It should be noted that, although the International SAR Co-operation Plans Index is administered at MRCC Falmouth, and MRCC Falmouth also acts as SAR data provider for some ships, the two functions are distinct. Generally, it is recommended that operators choose a SAR data provider within the ship's geographical area of operation.
- 8.16 It is, however, essential, if the SAR data provider system is to be used, that an entry is made on the International SAR Co-operation Plans Index as described in paragraph 8.13 above.

## 9 Periodic exercises

- 9.1 The regulation requires that the co-operation plan include provisions for periodic exercises to be undertaken to test its effectiveness.
- 9.2 Both frequency and type of exercise will depend on the circumstances in which the ship operates, availability of SAR service resources, etc.
- 9.3 While it is very important that SAR co-operation arrangements be tested from time to time – by, for example, requesting local SAR service involvement in exercises already being run in accordance with the ISM Code and each ship's safety management system requirements – it is also important that the benefits of such exercises are not diluted by over-exercising, or by always exercising in particular ways or with particular authorities. Therefore the ship should not be required to exercise her SAR co-operation arrangements more than once in any twelve month period.
- 9.4 The aim should be to test all parts of the emergency response network realistically, over time. A wide variety of scenarios should be employed; different SAR services should be involved if appropriate; and exercises should be so arranged as to allow all relevant staff (including relief staff) to participate over time.
- 9.5 Various types of exercise are acceptable: 'full-scale' or 'live', 'co-ordination', and/or 'communications' exercises<sup>10</sup> may all be appropriate, so long as the fundamental principle of co-operation between ship, company and SAR services is exercised. 'Tabletop' exercises, SAR seminars and liaison exchanges involving ship's personnel, shore-based company emergency response personnel and SAR service personnel can also be beneficial.
- 9.6 Exercises should be co-ordinated, to ensure efficient use of available resources. The principle of reciprocity applies. If a ship has conducted a SAR co-operation exercise within the last twelve months, she should be deemed by all parties to have fulfilled the requirements of the regulation: the 'SAR service' should be considered a global entity in this context. Likewise, the SAR services of individual states should co-operate to ensure that passenger ships' exercise requirements are distributed between them in a way appropriate to available resources.

---

<sup>9</sup> The link given here has been updated since the original publication of MSC Circular 1079. However, the link originally published – [www.mcga.gov.uk/sandr/coop.htm](http://www.mcga.gov.uk/sandr/coop.htm) – will still operate.

<sup>10</sup> IAMSAR Vol I, Chapter 3.3 refers.

- 9.7 Exercises conducted under this regulation should occasionally include the passenger ship taking on the role of a SAR facility – and in particular the role of On Scene Co-ordinator, if appropriate.
- 9.8 Ships which have participated in actual SAR incidents may be deemed to have fulfilled the exercise requirements of this regulation.
- 9.9 Exercises conducted under this regulation should be formally recorded by all the main participants (ship, company, and SAR service). The record should include at least the date, location and type of exercise, and a list of the main participants. A copy of the record should be available aboard the ship for inspection.
- 10 Keeping the co-operation plan up-to-date**
- 10.1 The information contained in each SAR co-operation plan must be kept up-to-date. Review, updating and auditing of the SAR co-operation plan should be conducted as part of the safety management system required by the ISM Code.
- 10.2 SAR service and SAR data provider information contained in each SAR co-operation plan should be reviewed, updated and audited in a similar way.
- 10.3 The International SAR Co-operation Plans Index must also be kept up-to-date. It is the SAR data provider's responsibility to ensure that this is done. SAR data providers should therefore check whether any amendments made to the co-operation plan affect the Index entry and, if so, should proceed in accordance with paragraph 8 above.

## APPENDIX 1

### **PLAN FOR CO-OPERATION BETWEEN SEARCH AND RESCUE SERVICES AND PASSENGER SHIPS NOT USING THE SAR DATA PROVIDER SYSTEM** **(IN ACCORDANCE WITH SOLAS REGULATION V/7.3)**

List of Contents

Introduction<sup>11</sup>

Description of a Plan for Co-operation<sup>12</sup>

- 1 The Company<sup>13</sup>
  - .1 name and address
  - .2 contact list
    - .1 24 hour emergency initial and alternative contact arrangements
    - .2 further communications arrangements (including direct telephone / fax links to relevant personnel)
  - .3 chartlet(s) showing details of route(s) and service(s) together with delimitation of relevant search and rescue regions (SRRs)<sup>14</sup>
  - .4 liaison arrangements between the Company and relevant RCCs<sup>15</sup>
    - .1 provision of relevant incident information
      - how specific information will be exchanged at the time of an incident, including details of persons, cargo and bunkers on board, SAR facilities and specialist support available at the time, etc
    - .2 provision of liaison officer(s)
      - arrangements for sending Company liaison officer(s) to the RCC, with access to supporting documentation concerning the Company and the ship(s); eg, copies of fire control & safety plans as required by the flag state
- 2 The ship(s)<sup>16</sup>
  - .1 [ship 1]<sup>17</sup>
    - .1 basic details of the ship

---

<sup>11</sup> To be prepared by the SAR Service

<sup>12</sup> To be prepared by the SAR Service

<sup>13</sup> As defined in the ISM Code

<sup>14</sup> The chartlet may be replaced by a simple description, if appropriate.

<sup>15</sup> ie, how Company and SAR Service are to work together in the event of an emergency, including the provision of that information which will only be available at the time

<sup>16</sup> To be prepared by the Company

<sup>17</sup> Enter here the ship's name

- MMSI
- call sign
- country of registry
- type of ship
- gross tonnage
- length overall (in metres)
- maximum permitted draught (in metres)
- service speed
- maximum number of persons allowed on board
- number of crew normally carried
- medical facilities

.2 communications equipment carried<sup>18</sup>

.3 simple plan of decks and profile of the ship, transmittable by electronic means, and including basic information on

- lifesaving equipment
- firefighting equipment
- plan of helicopter deck / winching area with approach sector
- helicopter types for which helicopter deck is designed
- means on board intended to be used to rescue people from the sea or from other vessels

and a colour picture of the ship

.2 [ship 2 – as for ship 1, etc]

### 3 The RCC(s)<sup>19</sup>

.1 search and rescue regions along the route

- chartlet showing SRRs in relevant area of ships' operation

.2 SAR mission co-ordination (SMC)

- definition
- summary of functions

.3 on scene co-ordination (OSC)

- definition
- selection criteria
- summary of functions

### 4 SAR facilities<sup>20</sup>

.1 [SRR ]<sup>21</sup>

.1 RCC/RSCs along the route

- addresses

<sup>18</sup> Enter here basic information on the ship's communications fit, frequencies available, identifiers, etc

<sup>19</sup> To be prepared by the SAR service

<sup>20</sup> To be prepared by the SAR service.

<sup>21</sup> Enter here the name of the relevant state.

- .2 communications
  - equipment
  - frequencies available
  - watch maintained
  - contact list (MMSIs, callsigns, telephone, fax and telex numbers)
- .3 general description and availability of designated SAR units (surface and air) and additional facilities along the route, eg:
  - fast rescue vessels
  - other vessels
  - heavy / light helicopters
  - long range aircraft
  - fire fighting facilities
- .4 communications plan
- .5 search planning
- .6 medical advice / assistance
- .7 firefighting, chemical hazards, etc
- .8 shore reception arrangements
- .9 informing next-of-kin
- .10 suspension / termination of SAR action

.2 [SRR 2 – as for SRR 1, etc]

5 Media relations<sup>22</sup>

6 Periodic exercises<sup>23</sup>

---

<sup>22</sup> To be prepared jointly by the Company and each SAR Service concerned.

<sup>23</sup> Frequency, form and content of training to be considered jointly by the Company and the SAR Service(s) concerned.

## APPENDIX 2

### SIMPLIFIED PLAN FOR CO-OPERATION BETWEEN SEARCH AND RESCUE SERVICES AND PASSENGER SHIPS USING THE SAR DATA PROVIDER SYSTEM (IN ACCORDANCE WITH SOLAS REGULATION V/7.3)

#### Introduction

- 1 The Company<sup>24</sup>
  - .1 name and address
  - .2 contact list
    - .1 24 hour emergency initial and alternative contact arrangements
    - .2 further communications arrangements (including direct telephone / fax links to relevant personnel)
  - .3 chartlet(s) showing details of route(s) and service(s) together with delimitation of relevant search and rescue regions (SRRs)<sup>25</sup>
  
- 2 The ship(s)<sup>26</sup>
  - .1 [ship 1]<sup>27</sup>
    - .1 basic details of the ship
      - MMSI
      - callsign
      - country of registry
      - type of ship
      - gross tonnage
      - length overall (in metres)
      - maximum permitted draught (in metres)
      - service speed
      - maximum number of persons allowed on board
      - number of crew normally carried
      - medical facilities
    - .2 communications equipment carried<sup>28</sup>
    - .3 simple plan of decks and profile of the ship, transmittable by electronic means, and including basic information on
      - lifesaving equipment

---

<sup>24</sup> As defined in the ISM Code

<sup>25</sup> The chartlet may be replaced by a simple description, if appropriate.

<sup>26</sup> To be prepared by the Company

<sup>27</sup> Enter here the ship's name

<sup>28</sup> Enter here basic information on the ship's communications fit, frequencies available, identifiers, etc

- firefighting equipment
- arrangements for working with helicopters

and a picture of the ship

.2 [ship 2 – as for ship 1, etc]

3 SAR Data Provider

.1 [ ]<sup>29</sup>

.1 address

.2 contact arrangements

4 Media relations<sup>30</sup>

5 Periodic exercises<sup>31</sup>

---

<sup>29</sup> Enter here the name of the SAR data provider.

<sup>30</sup> Details of the Company's arrangements for working with the news media should be entered here.

<sup>31</sup> Exercises should be co-ordinated between the parties involved to ensure efficient use of available resources.

### APPENDIX 3

#### SAR CO-OPERATION PLANNING: FLOW DIAGRAMS

1. Administrative requirements for ships not using the SAR data provider system (paragraph 7)

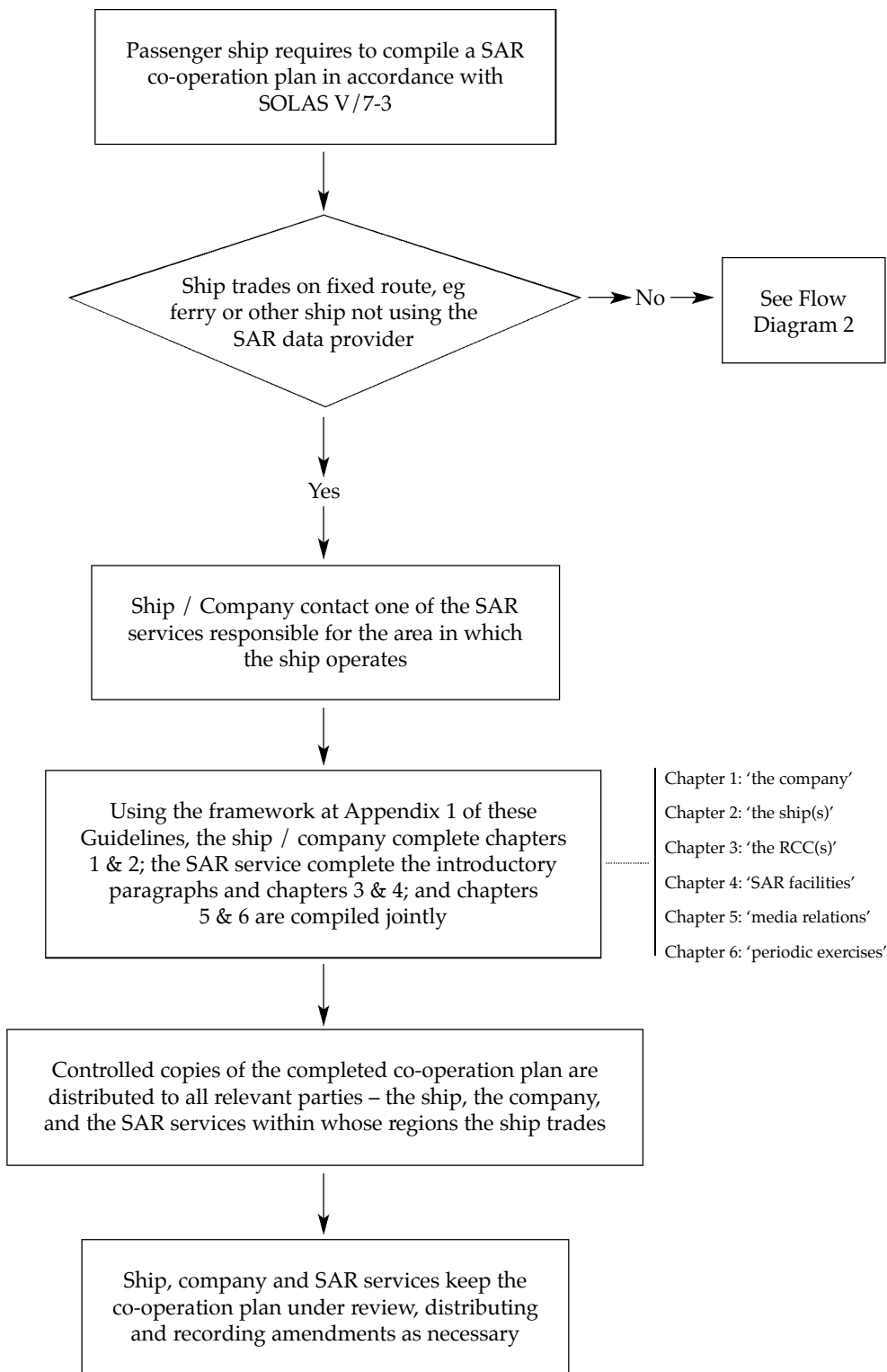

2. Administrative requirements for ships which are using the SAR data provider system (paragraph 8)

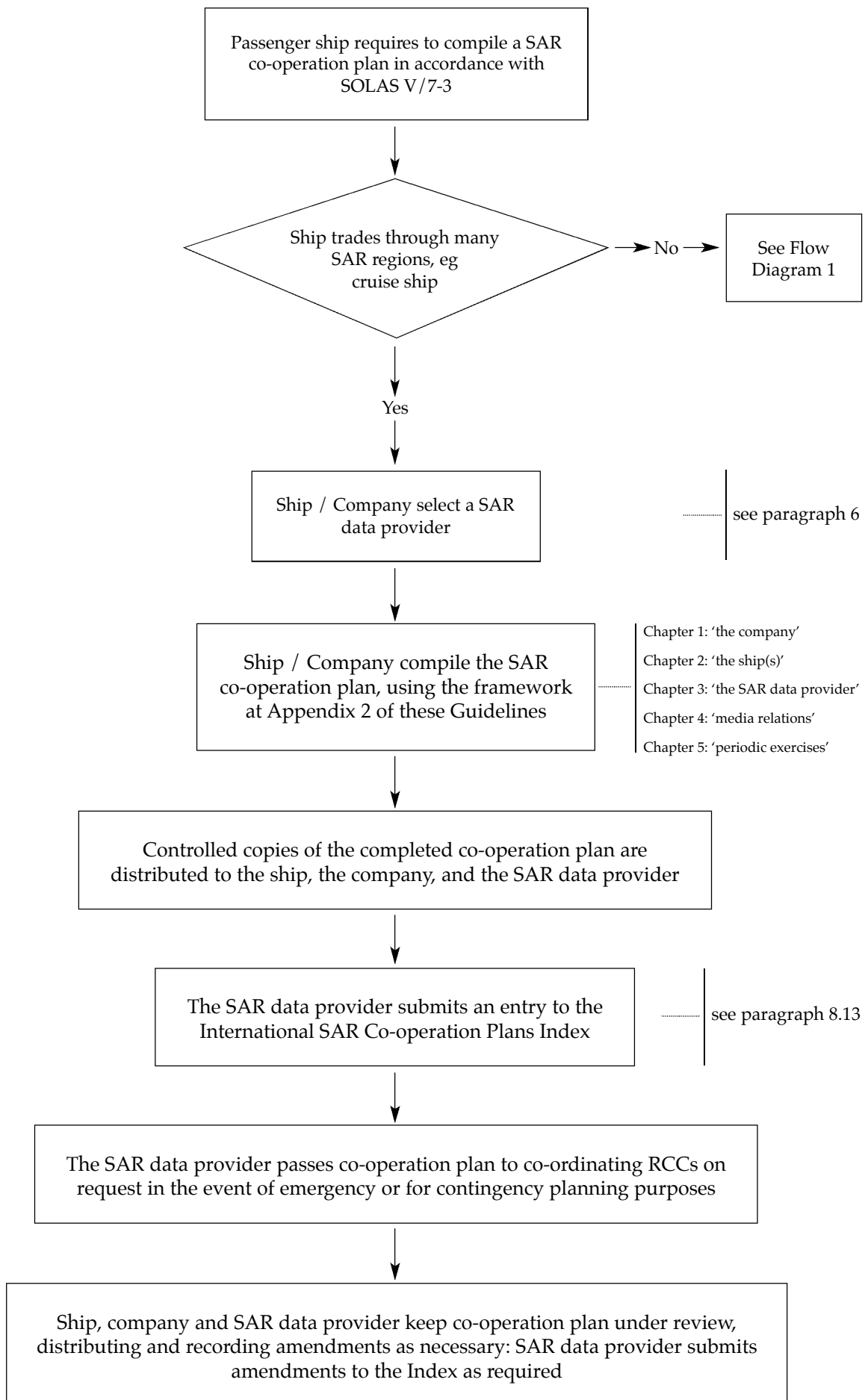

**EXAMPLE OF A SIMPLIFIED PLAN FOR VESSELS OPERATING  
IN UK INLAND WATERS**

1. Operator details
  - .1 name and address
  - .2 contact telephone number(s) - available on a 24-hour basis if possible, or at least during the vessel's period of operation
  - .3 fax number(s) - if applicable
  - .4 chartlet(s) showing details of route(s) and service(s) provided
  - .5 liaison arrangements between the operator and relevant local emergency services
  
2. The vessel(s)
  - .1 basic details of vessel
    - gross tonnage
    - length overall (in metres)
    - maximum permitted draught (in metres)
    - service speed
    - maximum number of persons allowed on board
    - number of crew normally carried
  - .2 communications equipment carried
  - .3 general plan of decks and profile of the vessel, including basic information on
    - lifesaving equipment
    - firefighting equipment

## ARRANGEMENTS FOR CO-OPERATION BETWEEN SAR SERVICES AND PASSENGER SHIPS:

### HM COASTGUARD ADMINISTRATIVE CONTACTS

The following addresses and contact numbers are for use by Company 'contact persons' when initiating contact with HM Coastguard for the purpose of drawing up the SAR Co-operation Plans. Please note that the telephone numbers listed below are for administration offices usually only open during working hours.

MRSC Shetland HM Coastguard The Knab Knab Road LERWICK ZE1 0AX	tel: 01595 743500 fax: 01595 696816
---	--

MRCC Aberdeen HM Coastguard 4th Floor Marine House Blaikies Quay ABERDEEN AB11 5PB	tel: 01224 597929 fax: 01224 573720
--	--

MRSC Forth HM Coastguard Fifeness CRAIL KY10 3XN	tel: 01333 452000 fax: 01333 451438
--	--

MRSC Humber HM Coastguard Limekiln Lane BRIDLINGTON YO15 2LX	tel: 01262 607334 fax: 01262 400646
--	--

MRCC Yarmouth HM Coastguard 4th Floor Havenbridge House North Quay GREAT YARMOUTH NR30 1HZ	tel: 01493 841302 fax: 01493 841324
--	--

MRSC Thames HM Coastguard East Terrace WALTON ON THE NAZE CO14 8PY	tel: 01255 682104 fax: 01255 682103
--	--

London Coastguard Thames Barrier Navigation Centre Unit 28 30 Bowater Road Woolwich LONDON SE18 5TF	tel: 020 8312 7380 fax: 020 8312 7679
MRCC Dover HM Coastguard Langdon Battery Swingate DOVER CT15 5NA	tel: 01304 218504 fax: 01304 218505
MRSC Solent HM Coastguard 44A Marine Parade West LEE ON SOLENT PO13 9NR	tel: 023 9255 9000 fax: 023 9255 9005
MRSC Portland HM Coastguard Custom House Quay WEYMOUTH DT4 8BE	tel: 01305 763600 fax: 01305 763603
MRSC Brixham HM Coastguard Kings Quay BRIXHAM TQ5 9TW	tel: 01803 884000 fax: 01803 884004
MRCC Falmouth HM Coastguard Pendennis Point Castle Drive FALMOUTH TR11 4WZ	tel: 01326 310800 fax: 01326 314331
MRCC Swansea HM Coastguard Tutt Head Mumbles SWANSEA SA3 4EX	tel: 01792 365300 fax: 01792 365334
MRSC Milford Haven HM Coastguard Gorsewood Drive Hakin MILFORD HAVEN SA73 3HB	tel: 01646 699600 fax: 01646 699603

MRSC Holyhead  
HM Coastguard  
Prince of Wales Road  
HOLYHEAD  
LL65 1ET

tel: 01407 767950  
fax: 01407 767954

MRSC Liverpool  
HM Coastguard  
Hall Road West  
Crosby  
LIVERPOOL  
L23 8SY

tel: 0151 931 6600  
fax: 0151 931 6604

MRCC Clyde  
HM Coastguard  
Navy Buildings  
Eldon Street  
GREENOCK  
PA16 7QY

tel: 01475 553350  
fax: 01475 731935

MRSC Stornoway  
HM Coastguard  
Clan Macquarrie House  
Battery Point  
STORNOWAY  
HS1 2RT

tel: 01851 708450  
fax: 01851 706193

MRSC Belfast  
HM Coastguard  
Bregenz House  
Quay Street  
BANGOR  
BT20 5ED

tel: 028 9147 5300  
fax: 028 9147 5312

To initiate UK-wide arrangements, or in case of difficulty, please contact:

Emergency Response Liaison Officer  
Directorate of Operations  
The Maritime and Coastguard Agency  
Bay 1/07, Spring Place  
105 Commercial Road  
SOUTHAMPTON  
SO15 1EG

tel: 023 8032 9108  
fax: 023 8032 9488

---

---

## LIFEBOATS - Measures to Prevent Accidents

Notice to all Ship Owners, Ship Operators and Managers, Masters, Officers and Crews of Merchant Ships

---

---

**PLEASE NOTE:-**

Where this document provides guidance on the law it should not be regarded as definitive. The way the law applies to any particular case can vary according to circumstances - for example, from vessel to vessel and you should consider seeking independent legal advice if you are unsure of your own legal position.

**Summary**

This Merchant Shipping Notice compiles current guidance on the safe servicing, testing maintenance and drilling of lifeboats.

- This Notice transposes the International Maritime Organization, Maritime Safety Committee Circular 1206 **MEASURES TO PREVENT ACCIDENTS WITH LIFEBOATS**
- It also sets the standard required for the approval of Independent Lifeboat Servicing and Testing Companies.

### 1. Introduction/ Background

1.1 In recent years the Maritime Industry has suffered an unacceptably high number of accidents with lifeboats in which crew were injured, sometimes fatally, whilst participating in lifeboat drills and/or inspections. It has been noted that most accidents fall under the following categories:

- Failure of on-load release mechanism;
- Inadvertent operation of on-load release mechanism;
- Inadequate maintenance of lifeboats, davits and launching equipment;
- Communication failures;
- Lack of familiarity with lifeboats, davits, equipment and associated controls;
- Unsafe practices during lifeboat drills and inspections; and
- Design faults other than on-load release mechanisms.

1.2 In response to these concerns, the International Maritime Organization (IMO) has produced guidance relating to the safe servicing, maintenance and drilling of lifeboats. In addition, surveyors from the Maritime and Coastguard Agency (MCA) are often questioned with regard to the requirement for MCA surveyors to be in attendance when lifeboats and their launching appliances are subjected to 5 yearly load testing. This MSN highlights the most pertinent IMO guidance and also provides some additional guidance with respect to 5 yearly load testing on board UK vessels.

1.3 This MSN aims to achieve the following goals:

- Lifeboat drills are conducted in accordance with SOLAS regulation III/19.3.3 for the purpose of ensuring that ship's personnel will be able to safely embark and launch the lifeboats in an emergency;
- Personnel undertaking inspections, maintenance and adjustment of lifeboats, launching appliances and associated equipment are fully trained and familiar with these duties;
- All appropriate documentation for the maintenance and adjustment of lifeboats, launching appliances and associated equipment is available on board;
- Maintenance of lifeboats, launching appliances and associated equipment is carried out in accordance with approved established procedures;
- The principles of health and safety at work apply to lifeboat drills;
- Personnel undertaking maintenance and repair activities are appropriately qualified;
- Hanging-off pennants are only used for maintenance purposes and not during training exercises;
- All tests required for the design and approval of life-saving appliances are conducted rigorously, according to the guidelines developed by the Maritime and Coastguard Agency, in order to identify and rectify any design faults at an early stage;
- The equipment to be easily accessible for inspections and maintenance and is proven durable in harsh operational conditions, in addition to withstanding prototype tests; and
- The Maritime and Coastguard Agency pays close attention to proper workmanship and technology when assessing equipment for approval; and
- Shipowners, when undertaking maintenance and repair activities, to employ qualified personnel, preferably certified by the manufacturer.

1.4 This Notice transposes the MSC Circular 1206 **MEASURES TO PREVENT ACCIDENTS WITH LIFEBOATS** which consolidates the guidance contained in Circulars; MSC/Circ.1049, MSC/Circ.1093, MSC/Circ.1136 and MSC/Circ 1137.

1.5 The guidance below is to be read in conjunction with the requirements of SOLAS Chapter III, with particular reference to Regulations 20 and 36, and also the requirements of the LSA Code, with particular reference to section 4.4.7.

**2. Format of guidance within this MSN**

2.1 Specific guidance for 5 yearly load testing on board UK vessels and relevant extracts from the text of the pertinent IMO guidance document are included in the form of an annex to this MSN as follows:

**ANNEX MEASURES TO PREVENT ACCIDENTS WITH LIFE BOATS.**

**Part 1. GUIDELINES FOR PERIODIC SERVICING AND MAINTENANCE OF LIFEBOATS, LAUNCHING APPLIANCES AND ON-LOAD RELEASE GEAR**

**APPENDIX 1: SPECIFIC PROCEDURES FOR MAINTENANCE AND SERVICING.**

**APPENDIX 2: GENERAL GUIDANCE ON THE CONDUCT OF 5 YEARLY LOAD TESTS ON UK VESSELS.**

**APPENDIX 3: APPROVAL PROCEDURE FOR INDEPENDENT LIFEBOATS SERVICING COMPANIES.**

**Part 2 GUIDELINES ON SAFETY DURING ABANDON SHIP DRILLS USING LIFEBOATS**

**Part 3 FREE-FALL LIFEBOATS**

## More Information

Shipping Safety Branch  
Maritime and Coastguard Agency  
Bay 2/11  
Spring Place  
105 Commercial Road  
Southampton  
SO15 1EG

Tel : +44 (0) 23 8032 9120  
Fax : +44 (0) 23 8032 9251  
e-mail: [Shipping\\_Safety@mcga.gov.uk](mailto:Shipping_Safety@mcga.gov.uk)

General Inquiries: 24 Hour Infoline  
[infoline@mcga.gov.uk](mailto:infoline@mcga.gov.uk)  
0870 600 6505

MCA Website Address: [www.mcga.gov.uk](http://www.mcga.gov.uk)

File Ref: MS003/091/003

Published: August 2006

© Crown Copyright 2006

**Safer Lives, Safer Ships, Cleaner Seas**

*Printed on material containing minimum 75% post-consumer waste paper*



An executive agency of the  
Department for  
**Transport**

## **ANNEX: MEASURES TO PREVENT ACCIDENTS WITH LIFE BOATS.**

### **PART 1: GUIDELINES FOR PERIODIC SERVICING AND MAINTENANCE OF LIFEBOATS, LAUNCHING APPLIANCES AND ON-LOAD RELEASE GEAR**

#### **1. General**

- 1.1 The objective of these Guidelines is to establish a uniform, safe and documented performance of periodic servicing and maintenance of lifeboats, launching appliances and on-load release gear.
- 1.2 These Guidelines relate to the application of the ISM Code to periodic servicing and maintenance of lifeboat arrangements and should therefore be reflected in procedures developed for a ship under that Code.
- 1.3 The general principle in these Guidelines may also be applied to the periodic servicing and maintenance of liferafts, rescue boats and fast rescue boats and their launching appliances and release gear. See Also MGN 317 *Servicing of Inflatable Liferafts, Inflatable Boats, Rescue Boats, Fast Rescue Boats, Inflatable Lifejackets and Hydrostatic Release Units* and MSN 1248 *Automatic Release Hooks for Liferafts and Disengaging Gear for Lifeboats and Rescue Boats*.
- 1.4 Detailed guidance regarding some procedures covered by these Guidelines is provided in the appendices 1 and 2.

#### **2. SOLAS regulations**

These Guidelines relate to the requirements contained in:

- 2.1 SOLAS regulation III/20. Operational readiness, maintenance and inspections; and
- 2.2 SOLAS regulation III/36. Instructions for on-board maintenance.

#### **3. Responsibility**

- 3.1 Both the shipping company and the company contracted to undertake the servicing are responsible for servicing and maintenance onboard its ships and for the establishment and implementation of health, safety and environment (HSE) procedures covering all activities during servicing and maintenance.
- 3.2 The personnel carrying out servicing and maintenance are responsible for the performance of the work as authorised in accordance with the system specified in 4.1.
- 3.3 The above personnel are also responsible for complying with HSE instructions and procedures.
- 3.4 Where satisfied with such an organisation's ability to carry out these functions, the MCA may authorise such organisation and its personnel to perform the functions of the manufacturer and manufacturer's certified personnel as assigned under this MSN. In order to gain this approval the Independent Lifeboat Servicing and Testing Organisation (ILSTO) should follow the procedure in Appendix 3 to Part 1 of this MSN.

#### **4. Authorisation**

- 4.1 Where these Guidelines require certification of accredited service personnel, such certification should be issued by the manufacturer or the ILSTO, in accordance with an established system for training and authorisation.

## **5. Qualification levels**

- 5.1 Weekly and monthly inspections, and routine maintenance as defined by the manufacturer, should be conducted under the direct supervision of a senior ship's officer in accordance with the instructions provided by the manufacturer.
- 5.2 All other inspections, servicing, testing and repair should be conducted by accredited service personnel.

## **6. Reports and records**

- 6.1 All reports and checklists should be correctly completed out and signed by the person who carries out the inspection and maintenance work and should also be signed by the company's representative or the ship's master.
- 6.2 Records of inspections, servicing, repairs and maintenance should be updated and filed onboard the ship.
- 6.3 When repairs or servicing are completed, a statement confirming that the lifeboat arrangements remain fit for purpose should be issued by the accredited service personnel.

## **APPENDIX 1: SPECIFIC PROCEDURES FOR MAINTENANCE AND SERVICING**

### **App1.1. GENERAL**

**App1.1.1** Any inspection, servicing and repair should be carried out according to the system for inspection and services developed by the manufacturer.

**App1.1.2** A full set of maintenance manuals and associated documentation issued by the manufacturer should be available on board for use in all operations involved in the inspection, maintenance, adjustment and re-setting of the lifeboat and associated equipment, such as davits and release gear.

**App1.1.3** The manufacturer's system for inspection and services should include the items contained in App1.2, App1.3 and App1.4 as a minimum.

**App1.1.4** All the inspections, testing and servicing required in App1.2, App1.3 and App1.4 should be conducted by accredited service personnel and all unnecessary personnel should be prohibited from entering the area of risk.

### **App1.2 ANNUAL THOROUGH EXAMINATION**

**App1.2.1** Items listed in checklists for the weekly/monthly inspections also form the first part of the annual thorough examination. When carrying out this examination the inspection of these items should be performed by the ship's crew in the presence of accredited service personnel and any recommendations or new procedures should be demonstrated then

**App1.2.2** Inspection and maintenance records of inspections and routine maintenance carried out by the ship's crew and the applicable certificates for the launching appliances and equipment should be available.

**App1.2.3** Repairs and replacement of parts should be carried out in accordance with the manufacturer's requirements and standards.

#### **App1.2.4 Lifeboats**

The following items should be examined and checked for satisfactory condition and operation:

- (a) Condition of lifeboat structure including fixed and loose equipment;
- (b) Engine and propulsion system;
- (c) Sprinkler system, where fitted;
- (d) Air supply system, where fitted;
- (e) Manoeuvring system;
- (f) Power supply system; and
- (g) Bailing system.

#### **App1.2.5 Release gear**

The following should be examined for satisfactory condition and operation after the annual winch brake test with the empty boat, as required by paragraph 3.1:

- (a) Operation of devices for activation of release gear;
- (b) Excessive free play (tolerances);
- (c) Hydrostatic interlock system, where fitted;
- (d) Cables for control and release; and
- (e) Hook fastening; including cheek plates, keel bolts etc.

**Notes:**

1. The setting and maintenance of release gear are critical operations with regard to maintaining the safe operation of the lifeboat and the safety of personnel in the lifeboat. All inspection and maintenance operations on this equipment should therefore be carried out with the utmost care.
2. No maintenance or adjustment of the release gear should be undertaken while the hooks are under load.
3. Hanging-off pennants may be used for this purpose but should not remain connected at other times, such as when the lifeboat is normally stowed and during training exercises. The crew needs to be assured that the structure is safe when loaded by hanging off pennants.
4. The release gear is to be examined prior to its operational test. The release gear is to be re-examined after its operational test and the dynamic winch brake test. Special consideration should be given to ensure that no damage has occurred during the winch brake test, especially to the hook closure and its fastening.

**App1.2.6 Operational test of on-load release function:**

- (a) Position the lifeboat partially into the water such that the mass of the boat is substantially supported by the falls and the hydrostatic interlock system, where fitted, is not triggered;
- (b) Operate the on-load release gear;
- (c) Reset the on-load release gear; and
- (d) Examine the release gear and hook fastening to ensure that the hook is completely reset and no damage has occurred.

**App1.2.7 Operational test of off-load release function:**

- (a) Position the lifeboat fully waterborne;
- (b) Operate the off-load release gear;
- (c) Reset the on-load release gear; and
- (d) Recover the lifeboat to the stowed position and verified ready for launching in an emergency

**Note:** Prior to hoisting, ensure that release gear is completely and properly reset with interlocks in place. The final turning-in of the lifeboat should be done without any persons on board.

**App1.2.8 Operational test of free-fall lifeboat release function:**

- (a) Engage the simulated launching arrangements as specified in the manufacturer's operating instructions;
- (b) The operator should be properly seated and secured in the seat location from which the release mechanism is to be operated;
- (c) Operate the release mechanism to release the lifeboat;
- (d) Reset the lifeboat in the stowed configuration;
- (e) Repeat procedures b) to d) above, using the back-up release mechanism, when applicable;
- (f) After ensuring that the boat is safely re-stowed remove the simulated launching arrangements; and
- (g) Verify that the lifeboat is in the ready to launch stowed configuration.

### App1.2.9 Davit

The following items should be examined for satisfactory condition and operation:

- (a) Davit structure, with particular regard to corrosion, particularly behind head sheaves and in other hard to paint places, misalignments, deformations and excessive free play, ego in bearings or track rollers;
- (b) Wires and sheaves, possible damage such as kinks and corrosion;
- (c) Lubrication of wires, sheaves and moving parts;
- (d) Functioning of all limit switches;
- (e) Stored power systems including a check on capacity; and
- (f) Hydraulic systems.
- (g) Inspection for correct termination of fall wire ends,
- (h) Verification of fall wire end for ending or replacement of wire
- (i) Condition and reaving of remote control wires, pulleys etc.

### App1.2.10 Winch

The following items should be examined for satisfactory condition and operation:

- (a) Open and inspect brake mechanism;
- (b) Replace brake pads, if necessary;
- (c) Remote control system;
- (d) Power supply system;
- (e) Winch foundation.
- (f) Winch crank handle interlocks; and
- (g) The angles / clearances of "dead mans" brake levers to be checked upon reassembly.

**Note:** See also MSN 1186 Lifeboat Winches Fitted with a Roller Ratchet Mechanism

### App1.3 DYNAMIC WINCH BRAKE TEST

**App1.3.1** Annual operational testing should preferably be done by lowering the empty boat. When the boat has reached its maximum lowering speed and before the boat enters the water, the brake should be abruptly applied.

**App1.3.2** The five-year operational test should be done by lowering the boat loaded to a proof load equal to 1.1 times the weight of the survival craft or rescue boat and its full complement of persons and equipment, or equivalent load. When the boat has reached its maximum lowering speed and before the boat enters the water, the brake should be abruptly applied.

**App1.3.3** Following these tests, the brake pads and stressed structural parts should be re-inspected.

**Note:**

In loading the boat for this test, precautions should be taken to ensure that the stability of the boat is not adversely affected by free surface effects or the raising of the centre of gravity.

**App1.3.4** In addition to the dynamic winch brake test under App1.3.2 for the secondary launching system of freefall lifeboats, every freefall lifeboat shall be freefall-launched every 5 years loaded to a proof load equal to 1.1 times the weight of the freefall boat and its full complement of persons and equipment. If the boat is launched unmanned without use of its own release system, the release system has to load- tested separately.

#### **App1.4 OVERHAUL OF ON-LOAD RELEASE GEAR**

Overhaul of on-load release gear includes:

- (a) Dismantling of hook release units;
- (b) Examination with regard to tolerances and design requirements;
- (c) Adjustment of release gear system after assembly;
- (d) Operational test as above and with a load according to SOLAS regulation III/20.11.2.3 at least once every 5 years; and
- (e) Examination of vital parts with regard to defects and cracks.

**Note:** Non-destructive examination (NDE) techniques, such as dye penetrants (DPE), may be suitable.

## **APPENDIX 2: GENERAL GUIDANCE ON THE CONDUCT OF 5 YEARLY LOAD TESTS ON UK VESSELS**

**App2.1** UK Regulation and SOLAS requires that “at least once every five years rescue boats and lifeboats shall be turned out and lowered when loaded with weights to simulate 1.1 times the total mass of the lifeboat or rescue boat when loaded with its full complement of persons and equipment or with an equivalent load.”

**App2.2** This test is to be applied to all lifeboats, liferaft davits and rescue boats. The procedure used must test the adequacy of all parts of the survival craft system – this includes boat, disengaging gears, davit, winch and foundations. In the case of liferafts there is a separate test carried out by the service stations. Load testing can be hazardous if not carried out correctly and therefore the role of all persons involved must be clear.

**App2.3** The test is to be carried out by accredited service personnel with a ship’s officer in charge (OIC) and witnessed by an authorised person.

The OIC is in charge of the test at all times and should brief those carrying out the test on what is required.

The authorised person should take no part in the test and should not be the OIC. The authorised person may be an MCA surveyor, a Classification Society Surveyor appointed by MCA, or other persons authorised by MCA to witness such tests. If the authorised person is not an MCA surveyor, then the individual concerned will require a letter of appointment from Survey Branch in MCA headquarters.

MCA authorised Class Societies should be aware of these procedures as this will have been given as part of a general authorisation.

**App2.4** All such tests are to be planned in advance. All routine maintenance and records are to be updated before the test. The authorised person must check this. It may be necessary to have a rolling programme for vessels with a large number of appliances. The boat, launching appliance and all relevant components are to be inspected on the day of the test by the OIC or delegated accredited service personnel to ensure that all is in order.

It is recommended that boats should be checked weighed before testing to confirm that the weight remains as previously recorded. Any increase in weight should be investigated. Water seepage into foam buoyancy is one possible cause, especially if benches have been cracked.

**App2.5** The lifeboat test may be carried out in various ways, each of which tests the whole system from boat to davit foundation. It is most important that all involved agree the actual detailed procedure in advance of the test. There are two main methods:

(a) Boats should be loaded up at the embarkation position. Where this is not the stowed position then the boat should be brought alongside the ship with the bowing gear arranged for release from the ship, rather than the boat as usual. Tricing pennants should be removed before loading commences. The boat should then be loaded with weights, distributed around the boat, until the boat and weights amount to a load of 1.1 times the weight of the boat when fully loaded with persons, equipment and stores.

Where the lifesaving capacity of the boat has been voluntarily reduced to a lower number of persons than that for which it was originally certified the full load weight may be calculated based on the lower number of persons, provided that the revised carrying capacity is marked on the boat and used on the passenger or safety equipment certificate. The weights may be either solid weights or water bags. The method of loading weights must be such that no-one enters the boat once the 90% load is reached.

If this cannot be achieved then the weight of the boat must not be taken by the falls during loading but by a crane (of capacity at least 2.2 times the loaded weight of the boat) and a spreader bar. Once loaded, the OIC should agree the test procedure with the attending authorised person and this subsequently explained to the accredited service personnel prior to the test. The attending surveyor should take no further part in the proceedings until the test is complete.

If a crane and spreader bar is used, this should then be lowered so the weight of the boat is taken on the falls. **Under no circumstances should anyone enter the boat at this time.** The boat is to be eased out on the bowsing tackles. The tricing lines should have been removed when the bowsing tackle was fitted. This must all be done from the vessel – which may require the rigging of temporary lines. **The OIC should now check the area under and around the boat is clear of persons and obstructions.** Once ready, the boat is to be lowered lifting the brake fully to enable the boat to reach maximum speed on the centrifugal brake. The mechanical brake is then applied suddenly and the test paused to ensure that the position of the boat is held at least 1 m above the water. If space permits, then it is repeated before the boat reaches the water. The boat is then lowered until the keel of the boat is just **touching the water.**

Boats fitted with on-load release mechanisms are to have these tested. The positioning of the boat is a matter of judgement depending on hull shape, but the weight of the boat should still be on the falls with the boat just touching the water surface. **On no account should the boat be dropped from above the water surface.**

Personnel can then enter the boat from another tender and override the release mechanism to release the boat to test that both hooks release simultaneously under load. Every care should be taken in this process. The personnel on the boat should wear protective clothing including safety helmets and life-jackets and should be sitting down when the boat is released. Davits should be visually checked at this stage.

Once released the weights may be removed from the boat. **Under no circumstances should the ships davits be used to lift the loaded boat.**

If the unloaded boat is to be raised on the falls, the hooks should be reset and the falls attached. The boat should be raised just clear of the water and the hook and interlock mechanism double checked and the secure location of the falls confirmed prior to full recovery. No persons should be in the boat while it is being hoisted on the falls until the hook mechanisms have been thoroughly examined by a competent person. Where the boat is to be hoisted before thorough examination of the hooks then it should be stowed securely by gripes or hanging off pennants while the competent person confirms that the equipment (hooks, boat, davits, winches, ...) have suffered no damage during the test

Once the boat is stowed and secured on the vessel the boat and davit should be inspected by the authorised person for any signs of test damage or straining (Non-destructive examination is strongly recommended at this point).

The results of the test should be recorded on a test certificate produced by the competent persons and signed by the witnessing authorised person.

- (b) Alternatively the boat and davits can be tested separately. This is more time consuming but can be useful in dry-dock situations. With this method the boat is tested by suspending it from a spreader bar and it is loaded to 200% of the weight of the boat when fully loaded with persons, equipment and stores.

This is not a dynamic test. It should be undertaken with caution. Although the boat is load tested in this way during type approval, there is a danger of damage to the boat if due care is not taken. Therefore before this is undertaken the advice of the accredited service personnel should be sought by the Company.

Separate tests are made of the davit and winch using weights, and a spreader bar if necessary, suspended from the falls. A load equivalent to 110% of the weight of the boat when fully loaded with persons, equipment and stores should be applied before the dynamic test is repeated as in (a). Static tests of the davit and winch to 200% load are not acceptable because a static test does not test the speed limiting brake in the winch and the winch is only subjected to a static test to 150% SWI when new.

Subsequently, the unloaded boat and davit should be inspected by the authorised person for any signs of test damage or straining (Non-destructive examination is strongly recommended at this point). The results of the test should be recorded on a test certificate produced by the accredited service personnel and signed by the witnessing authorised person.

- (c) Liferafts and some inflatable or partly inflatable rescue boats are subjected to load testing ashore during their regular servicing. The authorised person may waive on board load testing of boats when satisfied that testing has been done ashore with test loads and frequencies equivalent to that required in SOLAS III R20.11. Particular care must be taken where the on load release gear is part of the boat to ensure that it is test loaded and operated as per that regulation, either during servicing or on board. In such cases all that will need to be carried out on the ship is a 110% dynamic load test of the davit and brake using weights as per paragraph 3 of method (b) above. The test load will have to be calculated on the maximum load expected to be used with the davit in cases where the davit is shared by rafts and rescue boat.

On load release gear for rescue boats should be treated as for lifeboats and either tested as part of the davit and winch test, with operation at 110% load demonstrated afterwards or using an alternative means as per App 2.6.

- App2.6** An alternative method of testing on load release mechanisms may be available using specialist equipment. Some test houses have developed bespoke test equipment for this purpose. The applied load can be simulated hydraulically and the mechanism released in the usual way. This has the advantage that it can be done ashore and avoids the risk of damage to the boat or injury to personnel on loaded release in to the water. Use of such equipment must be agreed by the nominated body and the accredited service personnel. Any required calibration of such equipment must be verified.

This test should also be witnessed by an authorised person. The results of the test should be recorded on a test certificate produced by the test house or accredited service personnel and signed by the witnessing authorised person. In the case of boats without on-load release gear, the release gear should only be tested when the boat is fully waterborne.

**App2.7** Variations on the above methods may be used with the agreement of MCA; however each part of the survival craft and its launching appliance must be tested.

**App2.8** On completion of all testing the assembled boat and davit should be operationally tested to the satisfaction of the OIC before vessel departs or re-enters service.

### **APPENDIX 3: APPROVAL PROCEDURE FOR INDEPENDENT LIFEBOATS SERVICING AND TESTING ORGANISATIONS.**

Independent Lifeboat Servicing Companies wishing to acquire MCA approval for their operation should submit the following documentation:

- App3.1** Proof that their operation is certified and complies with a quality standard (ISO 9001 or equivalent). The standard procedures for the servicing of lifeboat systems should be submitted.
- App3.2** Portfolio justifying at least two years servicing experience with different manufacturer's equipment.
- App3.3** Traceability records system. A record system which provides traceability of work carried out and parts used must be maintained. All spare parts used should be the original manufacturer's spare parts. If the equipment manufacturer no longer exists and there are no original spare parts then the equipment should be replaced by equipment compliant with the Marine Equipment Directive ("Wheelmarked").
- App3.4** Accredited Service Personnel detailed Training Program.
- App3.5** All information referred in the preceding App3.1 to App3.4 should be readily available in case of an accident involving a lifeboat serviced by the Independent Lifeboat Servicing Company at the request of the MCA or The Maritime Accident Investigation Branch (MAIB).
- App3.6** All information (2 copies) referred in the preceding App3.1 to App3.4 should be sent the MCA's Marine Office nearest to the ILSTO or to the Survey Branch in the MCA's Head Quarters (foreign ILSTO should submit their documentation in English).

**The approval will last until 31<sup>st</sup> December 2008 after which the above Policy will be reviewed. Updated documentation may be required for re-approval. Independent Lifeboats Servicing Companies are recommended to acquire Manufacturers authorisation in the meanwhile.**

## **Part 2: GUIDELINES ON SAFETY DURING ABANDON SHIP DRILLS USING LIFEBOATS**

### **1 GENERAL**

#### **1.1. Introduction**

**1.1.1** It is essential that seafarers are familiar with the life-saving systems on board their ships and that they have confidence that the systems provided for their safety will work and will be effective in an emergency. Frequent periodic shipboard drills are necessary to achieve this.

**1.1.2** Crew training and rotation is an important component of drills. As a supplement to their initial shore side training, on board training will familiarise crew members with the ship systems and the associated procedures for use, operation and drills. On these occasions, the objective is to develop appropriate crew competencies, enabling effective and safe utilisation of the equipment required by the Regulations. The time limits set out in Regulations for ship abandonment should be considered as a secondary objective when conducting drills.

#### **1.2 Drill frequency**

**1.2.1** Experience has shown that holding frequent drills furthers the goal of making the crew familiar with the life-saving systems on board their ships and increasing their confidence that the systems will work and will be effective in an emergency. Drills give the crew opportunity to gain experience in the use of the safety equipment and working in co-operation with each other.

**1.2.2** The ability to cope with an emergency and handle the situation, if the ship needs to be abandoned, needs to be well rehearsed. However, frequent crew changes sometimes make it difficult to ensure that all on board have had the opportunity to participate in drills if the minimum required drills are conducted. Therefore, consideration needs to be given to scheduling drills as required to ensure all on board have an early opportunity to become familiar with the systems on board.

#### **1.3 Drills must be safe**

**1.3.1** Abandon ship drills should be planned, organised and performed so that the recognized risks are minimised and in accordance with relevant shipboard requirements of occupational health and safety.

**1.3.2** Drills provide an opportunity to verify that the life-saving system is working and that all associated equipment is in place and in good working order, ready for use.

**1.3.3** Before conducting drills, it should be checked that the lifeboat and its safety equipment have been maintained in accordance with the manufacturer's instructions, as well as noting all the precautionary measures necessary. Abnormal conditions of wear and tear or corrosion should be reported to the responsible officer immediately.

#### **1.4 Emphasis on learning**

**1.4.1** Drills should be conducted with an emphasis on learning and be viewed as a learning experience, not just as a task to meet a regulatory requirement to conduct drills.

**1.4.2** Whether they are emergency drills required by SOLAS or additional special drills conducted to enhance the competence of the crew members, they should be carried out at safe speed. During drills, care should be taken to ensure that everybody familiarises themselves with their duties and with the equipment.

If necessary, pauses should be made during the drills to explain especially difficult elements. The experience of the crew is an important factor in determining how fast a drill or certain drill elements should be carried out.

## **1.5 Planning and organising drills**

**1.5.1** Regulations require that drills shall, as far as practicable, be conducted as if there were an actual emergency. This means that the entire drill should, as far as possible, be carried out. At the same time, it should be ensured that the drill can be carried out in such a way that it is safe in every respect. Consequently, elements of the drill that may involve unnecessary risks will need special attention or may be excluded from the drill.

**1.5.2** In preparing for a drill, those responsible should review the manufacturer's instruction manual to assure that a planned drill is conducted properly. Those responsible for the drill should ensure that the crew is familiar with the guidance provided in the life-saving system instruction manual.

**1.5.3** Lessons learned in the course of a drill should be documented and made a part of follow-up shipboard training discussions and planning for the next drill session.

**1.5.4** The lowering of a boat with its full complement of persons is an example of an element of a drill that may, depending on the circumstances, involve unnecessary risk. Such drills should only be carried out if special precautions are observed.

## **2 ABANDON SHIP DRILLS**

### **2.1 Introduction**

**2.1.1** It is important that the crew who operate safety equipment on board are familiar with the functioning and operation of such equipment. Regulations require that sufficiently detailed manufacturer's training manuals and instructions be carried on board, which should be easily understood by the crew. Such manufacturer's manuals and instructions should be accessible for everyone on board and followed closely during drills.

### **2.2 Guidance to the shipowner**

**2.2.1** The shipowner should ensure that new safety equipment on board the company's ships has been approved and installed in accordance with UK regulations and that the different pieces of the lifeboat system (Lifeboat, hooks, davit, winch, etc) are all compatible and can work efficiently and safely together.

**2.2.2** Procedures for holding safe drills should be included in the Safety Management System (SMS) of shipping companies. Detailed procedures for elements of drills that involve a special risk should be evident from workplace assessments adjusted to the relevant life-saving appliance.

**2.2.3** Personnel carrying out maintenance and repair work on lifeboats should be qualified in accordance with part 1 of these Guidelines

### **2.3 Lifeboats lowered by means of falls**

**2.3.1** During drills, those responsible should be alert for potentially dangerous conditions and situations and should bring them to the attention of the responsible person for appropriate action.

Feedback and improvement recommendations to the ship-owner, the Administration and the system manufacturer are important elements of the marine safety system. If confidentiality is required any reporting can be made through the Confidential Hazardous Incident Reporting Program (CHIRP, [www.chirp.co.uk](http://www.chirp.co.uk))

- 2.3.2** Before placing persons onboard a lifeboat, it is recommended that the boat first be lowered and recovered without persons on board to ascertain that the arrangement functions correctly. The boat should then be lowered into the water with only the number of persons on board necessary to operate the boat.
- 2.3.3** To prevent lashings or gripes from getting entangled, proper release should be checked before swinging out the davit.

## **Part 3: FREE-FALL LIFEBOATS**

### **1 Free-fall lifeboats drill**

- 1.1** The monthly drills with free-fall lifeboats should be carried out according to the manufacturer's instructions, so that the persons who are to enter the boat in an emergency are trained to embark the boat, to take their seats in a correct way and to use the safety belts; and also are instructed on how to act during launching into the sea.
- 1.2** When the lifeboat is free-fall launched as part of a drill, this should be carried out with the minimum personnel required to manoeuvre the boat in the water and to recover it. The recovery operation should be carried out with special attention, bearing in mind the high risk level of this operation. Where permitted, simulated launching should be carried out in accordance with the manufacturer's instructions, taking due note of this MSN.

### **2 Guidelines for simulated launching of free-fall lifeboats**

Simulated launching is a means of training the crew in the free-fall release procedure for free-fall lifeboats and in verifying the satisfactory function of the free-fall release system without allowing the lifeboat to fall into the sea.

#### **2.1 Purpose and scope**

The purpose of these Guidelines is to provide a basic outline of essential steps necessary to safely carry out simulated launching. These Guidelines are general; the lifeboat manufacturer's instruction manual should always be consulted before conducting simulated launching. Simulated launching should only be carried out with lifeboats and launching appliances designed to accommodate it, and for which the manufacturer has provided instructions. Simulated launching should be carried out under the supervision of a responsible person who should be an officer experienced in such procedures.

#### **2.2 Typical simulated launching sequence**

- 2.2.1** Check equipment and documentation to ensure that all components of the lifeboat and launching appliance are in good operational condition.
- 2.2.2** Ensure that the restraining device(s) provided by the manufacturer for simulated launching are installed and secure and that the free-fall release mechanism is fully and correctly engaged.
- 2.2.3** Establish and maintain good communication between the assigned operating crew and the responsible person.
- 2.2.4** Disengage lashings, gripes, etc. installed to secure the lifeboat for sea or for maintenance, except those required for simulated free-fall.
- 2.2.5** Participating crew board the lifeboat and fasten their seatbelts under the supervision of the responsible person.
- 2.2.6** All crew, except the assigned operating crew, disembark the lifeboat. The assigned operating crew fully prepares the lifeboat for free-fall launch and secures themselves in their seats for the release operation.

- 2.2.7** The assigned operating crew activates the release mechanism when instructed by the responsible person. Ensure that the release mechanism operates satisfactorily and, if applicable, the lifeboat travels down the ramp to the distance specified in the manufacturer's instructions.
- 2.2.8** Re-secure the lifeboat to its stowed position, using the means provided by the manufacturer and ensure that the free-fall release mechanism is fully and correctly engaged.
- 2.2.9** Repeat procedures from 2.2.7 above, using the back-up release mechanism when applicable.
- 2.2.10** The assigned operating crew disembarks the lifeboat.
- 2.2.11** Ensure that the lifeboat is returned to its normal stowed condition. Remove any restraining and/or recovery devices used only for the simulated launch procedure.
- 2.2.12** The lifeboat should then be verified ready for launching in an emergency.

---

---

## **Mandatory Registration of Emergency Position Indicating Radio Beacons (EPIRBs)**

**Notice to all Owners, Masters and Skippers of vessels that carry EPIRBs**

*This notice replaces MSN 1732 (M+F) and MGN 302 (M+F).*

---

---

### **PLEASE NOTE:-**

Where this document provides guidance on the law it should not be regarded as definitive. The way the law applies to any particular case can vary according to circumstances - for example, from vessel to vessel and you should consider seeking independent legal advice if you are unsure of your own legal position.

### **Summary**

This Notice draws attention to, and gives advice regarding *The Merchant Shipping (EPIRB Registration) Regulations 2000*.

#### Key Points –

- 406 MHz beacons (EPIRB or PLB) fitted to a United Kingdom vessel must be registered with the appropriate authority.
- Changes to registered beacons must also be notified.
- It is an offence by the Owner and/or the Operator not to follow these requirements.

## **1. Introduction/ Background**

1.1 This Notice is associated with The Merchant Shipping (EPIRB Registration) Regulations 2000. It draws attention to the requirements of those Regulations, namely the mandatory registration of all 406 MHz beacons carried on UK registered ships. The UK EPIRB register also accepts 406 MHz Personal Locator Beacons (PLBs) used in a maritime environment.

1.2 The Regulations ensure that details held on the registers are as accurate as possible. There have been incidents where details were found to be wrong or out of date.

## **2. Need for accurate and timely registration details**

2.1 The effectiveness of a 406 MHz beacon as a Search and Rescue (SAR) aid depends upon correct registration details being available to the SAR services. If they are not, there is the potential to jeopardise SAR operations, including looking for the wrong vessel, or stopping a search because it might appear that the vessel with which the beacon is registered is not in distress.

### 3. Procedure for Registration

- 3.1 The beacon manufacturers normally provide two or more identical registration cards on which vessel operators should enter the required details, but these are also available from the Royal Yachting Association (Global Maritime Distress Safety System (GMDSS) Guidelines), Ofcom registration documentation and from the MCA via our website or the EPIRB Registry itself. One is to be returned to the manufacturer as a warranty, while another is sent to the competent authority. Any spare forms should be retained by the beacon owner.
- 3.2 Beacons that operate within the 406 MHz band must be registered with the MCA. The completed form or any registration queries should be sent to:

The EPIRB Registry  
The Maritime and Coastguard Agency  
MRCC Falmouth  
Castle Drive  
Pendennis Point  
Falmouth  
Cornwall TR11 4WZ

Tel: 01326 211569  
Fax: 01326 319264

Email: [epirb@mca.gov.uk](mailto:epirb@mca.gov.uk)

Online registration: <http://www.mca.gov.uk/c4mca/epirb>

Office hours: Mon – Thurs: 08:45 – 16:45 Fri: 08:45 – 16:15

Outside office hours or in the case of an alert:

Falmouth Coastguard Operations room: Tel: 01326 317575

The beacon supplier or the EPIRB Registry will help you complete the card correctly if you need assistance.

To save time and resources a single point of contact should be registered by operators for all UK ships<sup>1</sup> that they operate.

### 4. Timescale

- 4.1 Once a registration card has been received by the Registry it is normal practice to process and enter the new or changed information the same day it is received. Confirmation should be received by the owner within 14 days.

### 5. Beacon Coding

- 5.1 The UK can only accept beacons coded using MID codes 232 233 234 or 235. Accepted UK protocols are:

UK Serialised – where the beacon has a unique serial number  
UK Maritime Mobile Service Identity (MMSI) – allocated to the vessel  
UK location protocols – for GPS models

---

<sup>1</sup> The term 'ship' has the same meaning as in the Merchant Shipping Act 1995 section 313(1) namely that includes every description of vessel used in navigation.

Advice can be provided by the EPIRB Registry or the beacon manufacturer.

5.2 If information contained on the card is incorrect or we have a query, registration will be delayed. Ideally the owner will be contacted and the problem sorted as soon as possible; but this is not always the case where there are difficulties in making contact with vessel owners. Sometimes beacons need to be sent back to manufacturers or programmers for testing. It is advisable to check whether the beacon can be registered in good time prior to departure as difficulties may arise for vessels currently at sea.

5.3 If acknowledgement has not been received within three weeks the owner should contact the EPIRB Registry.

## **6. Hiring or Borrowing Beacons**

6.1 There are a number of Beacon hire companies, yacht delivery companies, programmer's spare service beacons and race competitors, who regularly change beacons from one vessel to another. This does not cause problems, provided the EPIRB Registry is notified of any changes of the registration details.

## **7. Proof of Registration**

7.1 Once registration details have been entered onto the Register, the following documents are sent to the owner which can be used as proof of registration:

- A covering letter;
- A printout of the entry;
- Two waterproof (proof of registration) 'sticky' labels; and
- A blank registration form

7.2 It is recommended that the printout is kept with the ships' documents as proof of registration and that the labels are attached to the beacon itself. (Note: labels should not be placed on the battery housing as this may be replaced during servicing.)

## **8. Change of Details**

8.1 The EPIRB Regulators will automatically contact all registered EPIRB holders every three years to check registration details. In the interim it is essential that any change(s) are notified to the Registry as in paragraph 3.2.

## **9. Offences**

9.1 The penalties are a fine not exceeding £1,000 for contraventions of Regulations 5(1) (requirement that the owner and operator correctly register any EPIRB carried on a ship) and 6 (requirement that the owner and operator notify the competent authority of any changes made with respect to a registered EPIRB) and £500 for contraventions of Regulation 5(3) (requirement that evidence of a correctly registered EPIRB carried on a ship is available on board for inspection at all times by a surveyor of ships.)

## More Information

Navigation Safety Branch  
Maritime and Coastguard Agency  
Bay 2/29  
Spring Place  
105 Commercial Road  
Southampton  
SO15 1EG

Tel : +44 (0) 23 8032 9356  
Fax : +44 (0) 23 8032 9204  
e-mail: [navigationsafety@mcga.gov.uk](mailto:navigationsafety@mcga.gov.uk)

General Inquiries: 24 Hour Infoline  
[infoline@mcga.gov.uk](mailto:infoline@mcga.gov.uk)  
0870 600 6505

MCA Website Address: [www.mcga.gov.uk](http://www.mcga.gov.uk)

File Ref: MNA 136/02/48

Published: August 2007

© Crown Copyright 2007



**Safer Lives, Safer Ships, Cleaner Seas**

An executive agency of the  
Department for  
**Transport**

*Printed on material containing minimum 75% post-consumer waste paper*