

FSS Code - Fire Safety Systems – Resolution MSC.98(73)



Document History

- . Amended by Resolution MSC.217(82)
 - . Amended by Resolution MSC.206(81)
 - . Amended by Resolution MSC.292(87)
 - . Amended by Resolution MSC.311(88)
 - . Amended by Resolution MSC.327(90)
 - . Amended by Resolution MSC.339(91)
-

The Maritime Safety Committee,

. RECALLING Article 28(b) of the Convention on the International Maritime Organization concerning the functions of the Committee,

. NOTING the revision of chapter II-2 of the International Convention for the Safety of Life at Sea (SOLAS), 1974 (hereinafter referred to as "the Convention"),

. RECOGNIZING the need to continue the mandatory application of the fire safety systems required by the revised chapter II-2 of the Convention,

. NOTING resolution MSC.99(73) by which it adopted, *inter alia*, the revised chapter II-2 of the Convention to make the provisions of the International Code for Fire Safety Systems (FSS Code) mandatory under the Convention,

. HAVING CONSIDERED, at its seventy-third session, the text of the proposed FSS Code,

1.. ADOPTS the International Code for Fire Safety Systems (FSS Code), the text of which is set out in the Annex to the present resolution;

2.. INVITES Contracting Governments to the Convention to note that the FSS Code will take effect on 1 July 2002 upon the entry into force of the revised chapter II-2 of the Convention;

3.. REQUESTS the Secretary-General to transmit certified copies of this resolution and the text of the FSS Code contained in the Annex to all Contracting Governments to the Convention;

4.. FURTHER REQUESTS the Secretary-General to transmit copies of this resolution and the Annex to all Members of the Organization which are not Contracting Governments to the Convention.

Annex - International Code For Fire Safety Systems



Preamble

1. The purpose of this Code is to provide international standards of specific engineering specifications for fire safety systems required by chapter II-2 of the International Convention for the Safety of Life at Sea (SOLAS), 1974, as amended.

2. On or after 1 July 2002, this Code will be mandatory for fire safety systems required by the 1974 SOLAS Convention, as amended. Any future amendment to the Code must be adopted and brought into force in accordance with the procedure laid down in Article VIII of the Convention.

Chapter 1 - General

1 Application

1.1. This code is applicable to fire safety systems as referred to in chapter II-2 of the International Convention for the Safety of Life at Sea, 1974, as amended.

1.2. Unless expressly provided otherwise, this Code is applicable for the fire safety systems of ships the keels of which are laid or which are at a similar stage of construction on or after 1 July 2002. However, amendments to the Code adopted after 1 July 2002 shall apply only to ships the keels of which are laid or which are at a similar stage of construction, on or after the date on which the amendments enter into force, unless expressly provided otherwise.

2 Definitions

2.1. *Administration* means the Government of the State whose flag the ship is entitled to fly.

2.2. *Convention* means the International Convention for the Safety of Life at Sea, 1974, as amended.

2.3. *Fire Safety Systems Code* means the International Code for Fire Safety Systems as defined in chapter II-2 of the International Convention for the Safety of Life at Sea, 1974, as amended.

2.4. For the purpose of this Code, definitions provided in chapter II-2 of the Convention also apply.

3 Use of equivalents and modern technology

. In order to allow modern technology and development of fire safety systems, the Administration may approve fire safety systems which are not specified in this Code if the requirements of Part F of chapter II-2 of the Convention are fulfilled.

4 Use of toxic extinguishing media

. The use of a fire-extinguishing medium which, in the opinion of the Administration, either by itself or under expected conditions of use gives off toxic gases, liquids and other substances in such quantities as to endanger persons shall not be permitted.

Chapter 2 - International Shore Connections

1 Application

. This chapter details the specifications for international shore connections as required by chapter II-2 of the Convention.

2 Engineering specifications

2.1. Standard dimensions

Standard dimensions of flanges for the international shore connection shall be in accordance with the following table:

Table 2.1 Standard dimensions for international shore connections

Description	Dimension
Outside diameter	178 mm
Inside diameter	64 mm
Bolt circle diameter	132 mm
Slots in flange	4 holes, 19 mm in diameter space equidistantly on a bolt circle of the above diameter, slotted to the flange periphery
Flange thickness	14.5 mm minimum
Bolts and nuts	4, each 16 mm diameter, 50 mm in length

2.2. Materials and accessories

International shore connections shall be of steel or other equivalent material and shall be designed for 1.0 N/mm² services. The flange shall have a flat face on one side and, on the other side, it shall be permanently attached to a coupling that will fit the ship's hydrant and hose. The connection shall be kept aboard the ship together with a gasket of any material suitable for 1.0 N/mm² services, together with four bolts of 16 mm diameter and 50 mm in length, four 16 mm nuts, and eight washers.

Chapter 3 - Personnel Protection

1 Application

. This chapter details the specifications for personnel protection as required by chapter II-2 of the Convention.

2 Engineering specifications

2.1 Fire-fighter's outfit

. A fire-fighter's outfit shall consist of a set of personal equipment and a breathing apparatus.

2.1.1. Personal equipment

Personal equipment shall consist of the following:

- .1. protective clothing of material to protect the skin from the heat radiating from the fire and from burns and scalding by steam. The outer surface shall be water-resistant;
- .2. boots of rubber or other electrically non-conducting material;
- .3. rigid helmet providing effective protection against impact;
- .4. electric safety lamp (hand lantern) of an approved type with a minimum burning period of 3 h. Electric safety lamps on tankers and those intended to be used in hazardous areas shall be of an explosion-proof type ^{see footnote} ; and
- .5. axe with a handle provided with high-voltage insulation.

2.1.2. Breathing apparatus

2.1.2.1. Breathing apparatus shall be a self-contained compressed air breathing apparatus for which the volume of air contained in the cylinders shall be at least 1,200 l, or other self-contained breathing apparatus which shall be capable of functioning for at least 30 min. All air cylinders for breathing apparatus shall be interchangeable.

2.1.2.2. Compressed air breathing apparatus shall be fitted with an audible alarm and a visual or other device which will alert the user before the volume of the air in the cylinder has been reduced to no less than 200 l.

2.1.3. Lifeline

For each breathing apparatus a fireproof lifeline of at least 30 m in length shall be provided. The lifeline shall successfully pass an approval test by static load of 3.5 kN for 5 min without failure. The lifeline shall be capable of being attached by means of a snap-hook to the harness of the apparatus or to a separate belt in order to prevent the breathing apparatus becoming detached when the lifeline is operated.

2.2 Emergency escape breathing devices (EEBD)

2.2.1. General

2.2.1.1. An EEBD is a supplied air or oxygen device only used for escape from a compartment that has a hazardous atmosphere and shall be of an approved type.

2.2.1.2. EEBDs shall not be used for fighting fires, entering oxygen deficient voids or tanks, or worn by firefighters. In these events, a self-contained breathing apparatus, which is specifically suited for such applications, shall be used.

2.2.2. Definitions

2.2.2.1. *Face piece* means a face covering that is designed to form a complete seal around the eyes, nose and mouth which is secured in position by a suitable means.

2.2.2.2. *Hood* means a head covering which completely covers the head, neck, and may cover portions of the shoulders.

2.2.2.3. *Hazardous atmosphere* means any atmosphere that is immediately dangerous to life or health.

2.2.3. Particulars

2.2.3.1. The EEBD shall have a service duration of at least 10 min.

2.2.3.2. The EEBD shall include a hood or full face piece, as appropriate, to protect the eyes, nose and mouth during escape. Hoods and face pieces shall be constructed of flame resistant materials and include a clear window for viewing.

2.2.3.3. An inactivated EEBD shall be capable of being carried hands-free.

2.2.3.4. An EEBD, when stored, shall be suitably protected from the environment.

2.2.3.5. Brief instructions or diagrams clearly illustrating their use shall be clearly printed on the EEBD. The donning procedures shall be quick and easy to allow for situations where there is little time to seek safety from a hazardous atmosphere.

2.2.4. Markings

. Maintenance requirements, manufacturer's trademark and serial number, shelf life with accompanying manufacture date and name of approving authority shall be printed on each EEBD. All EEBD training units shall be clearly marked.

FSS Code - Fire Safety Systems – Resolution MSC.98(73) - Annex - International Code For Fire Safety Systems - Chapter 4 - Fire Extinguishers

Chapter 4 - Fire Extinguishers

1 Application

. This chapter details the specifications for fire extinguishers as required by chapter II-2 of the Convention.

2 Type approval

. All fire extinguishers shall be of approved types and designs based on the guidelines developed by the Organization. ^{see footnote}

3 Engineering specifications

3.1 Fire extinguisher

3.1.1. Quantity of medium

3.1.1.1. Each powder or carbon dioxide extinguisher shall have a capacity of at least 5 kg and each foam extinguisher shall have a capacity of at least 9 l. The mass of all portable fire extinguishers shall not exceed 23 kg and they shall have a fire-extinguishing capability at least equivalent to that of a 9 l fluid extinguisher.

3.1.1.2. The Administration shall determine the equivalents of fire extinguishers.

3.1.2. Recharging

Only refills approved for the fire extinguisher in question shall be used for recharging.

3.2 Portable foam applicators

3.2.1. A portable foam applicator unit shall consist of a foam nozzle/branch pipe, either of a self-inducing type or in combination with a separate inductor, capable of being connected to the fire main by a fire hose, together with a portable tank containing at least 20 l of foam concentrate and at least one spare tank of foam concentrate of the same capacity.

3.2.2. System performance

3.2.2.1. The nozzle/branch pipe and inductor shall be capable of producing effective foam suitable for extinguishing an oil fire, at a foam solution flow rate of at least 200 l/min at the nominal pressure in the fire main.

3.2.2.2. The foam concentrate shall be approved by the Administration based on guidelines developed by the Organization ^{see footnote}.

3.2.2.3. The values of the foam expansion and drainage time of the foam produced by the portable foam applicator unit shall not differ more than $\pm 10\%$ of that determined in 3.2.2.2.

3.2.2.4. The portable foam applicator unit shall be designed to withstand clogging, ambient temperature changes, vibration, humidity, shock, impact and corrosion normally encountered on ships.

Chapter 5 - Fixed Gas Fire-Extinguishing Systems

1 Application

. This chapter details the specifications for fixed gas fire-extinguishing systems as required by chapter II-2 of the Convention.

2 Engineering specifications

2.1 General

2.1.1. Fire-extinguishing medium

2.1.1.1. Where the quantity of the fire-extinguishing medium is required to protect more than one space, the quantity of medium available need not be more than the largest quantity required for any one space so protected. The system shall be fitted with normally closed control valves arranged to direct the agent into the appropriate space.

2.1.1.2. The volume of starting air receivers, converted to free air volume, shall be added to the gross volume of the machinery space when calculating the necessary quantity of the fire-extinguishing medium. Alternatively, a discharge pipe from the safety valves may be fitted and led directly to the open air.

2.1.1.3. Means shall be provided for the crew to safely check the quantity of the fire-extinguishing medium in the containers.

2.1.1.4. Containers for the storage of fire-extinguishing medium, piping and associated pressure components shall be designed to pressure codes of practice to the satisfaction of the Administration having regard to their locations and maximum ambient temperatures expected in service. ^{see footnote}

2.1.2. Installation requirements

2.1.2.1. The piping for the distribution of fire-extinguishing medium shall be arranged and discharge nozzles so positioned that a uniform distribution of the medium is obtained. System flow calculations shall be performed using a calculation technique acceptable to the Administration.

2.1.2.2. Except as otherwise permitted by the Administration, pressure containers required for the storage of fire-extinguishing medium, other than steam, shall be located outside the protected spaces in accordance with regulation II-2/10.4.3 of the Convention.

2.1.2.3. Spare parts for the system shall be stored on board and be to the satisfaction of the Administration.

2.1.2.4. In piping sections where valve arrangements introduce sections of closed piping, such sections shall be fitted with a pressure relief valve and the outlet of the valve shall be led to open deck.

2.1.2.5. All discharge piping, fittings and nozzles in the protected spaces shall be constructed of materials having a melting temperature which exceeds 925°C. The piping and associated equipment shall be adequately supported.

2.1.2.6. A fitting shall be installed in the discharge piping to permit the air testing as required by paragraph 2.2.3.1.

2.1.3. System control requirements

2.1.3.1. The necessary pipes for conveying fire-extinguishing medium into the protected spaces shall be provided with control valves so marked as to indicate clearly the spaces to which the pipes are led. Suitable provisions shall be made to prevent inadvertent release of the medium into the space. Where a cargo space fitted with a gas fire-extinguishing system is used as a

passenger space, the gas connection shall be blanked during such use. The pipes may pass through accommodations providing that they are of substantial thickness and that their tightness is verified with a pressure test, after their installation, at a pressure head not less than 5 N/mm². In addition, pipes passing through accommodation areas shall be joined only by welding and shall not be fitted with drains or other openings within such spaces. The pipes shall not pass through refrigerated spaces.

2.1.3.2. Means shall be provided for automatically giving audible and visual warning of the release of fire-extinguishing medium into any ro-ro spaces and other spaces in which personnel normally work or to which they have access. The audible alarms shall be located so as to be audible throughout the protected space with all machinery operating, and the alarms should be distinguished from other audible alarms by adjustment of sound pressure or sound patterns. The pre-discharge alarm shall be automatically activated (e.g., by opening of the release cabinet door). The alarm shall operate for the length of time needed to evacuate the space, but in no case less than 20 s before the medium is released. Conventional cargo spaces and small spaces (such as compressor rooms, paint lockers, etc.) with only a local release need not be provided with such an alarm.

2.1.3.3. The means of control of any fixed gas fire-extinguishing system shall be readily accessible, simple to operate and shall be grouped together in as few locations as possible at positions not likely to be cut off by a fire in a protected space. At each location there shall be clear instructions relating to the operation of the system having regard to the safety of personnel.

2.1.3.4. Automatic release of fire-extinguishing medium shall not be permitted, except as permitted by the Administration.

2.2 Carbon dioxide systems

2.2.1. Quantity of fire-extinguishing medium

2.2.1.1. For cargo spaces, the quantity of carbon dioxide available shall, unless otherwise provided, be sufficient to give a minimum volume of free gas equal to 30% of the gross volume of the largest cargo space to be protected in the ship.

2.2.1.2. For vehicle spaces and ro-ro spaces which are not special category spaces, the quantity of carbon dioxide available shall be at least sufficient to give a minimum volume of free gas equal to 45% of the gross volume of the largest such cargo space which is capable of being sealed, and the arrangements shall be such as to ensure that at least two thirds of the gas required for the relevant space shall be introduced within 10 min. Carbon dioxide systems shall not be used for the protection of special category spaces.

2.2.1.3. For machinery spaces, the quantity of carbon dioxide carried shall be sufficient to give a minimum volume of free gas equal to the larger of the following volumes, either:

.1. 40% of the gross volume of the largest machinery space so protected, the volume to exclude that part of the casing above the level at which the horizontal area of the casing is 40% or less of the horizontal area of the space concerned taken midway between the tank top and the lowest part of the casing; or

.2. 35% of the gross volume of the largest machinery space protected, including the casing.

2.2.1.4. The percentages specified in paragraph 2.2.1.2 above may be reduced to 35% and 30%, respectively, for cargo ships of less than 2,000 gross tonnage where two or more machinery spaces, which are not entirely separate, are considered as forming one space.

2.2.1.5. For the purpose of this paragraph the volume of free carbon dioxide shall be calculated at 0.56 m³/kg.

2.2.1.6. For machinery spaces, the fixed piping system shall be such that 85% of the gas can be discharged into the space within 2 min.

2.2.1.7. For container and general cargo spaces (primarily intended to carry a variety of cargoes separately secured or packed) the fixed piping system shall be such that at least two thirds of the gas can be discharged into the space within 10 min. For solid bulk cargo spaces the fixed piping system shall be such that at least two thirds of the gas can be discharged into the space within 20 min. The system controls shall be arranged to allow one third, two thirds or the entire quantity of gas to be discharged based on the loading condition of the hold.

2.2.2. Controls

Carbon dioxide systems for the protection of ro-ro spaces, container holds equipped with integral reefer containers, spaces accessible by doors or hatches, and other spaces in which personnel normally work or to which they have access shall comply with the following requirements:

.1. two separate controls shall be provided for releasing carbon dioxide into a protected space and to ensure the activation of the alarm. One control shall be used for opening the valve of the piping which conveys the gas into the protected space and a second control shall be used to discharge the gas from its storage containers. Positive means shall be provided so they can only be operated in that order; and

.2. the two controls shall be located inside a release box clearly identified for the particular space. If the box containing the controls is to be locked, a key to the box shall be in a break-glass-type enclosure conspicuously located adjacent to the box.

2.2.3. Testing of the installation

When the system has been installed, pressure-tested and inspected, the following shall be carried out:

.1. a test of the free air flow in all pipes and nozzles; and

.2. a functional test of the alarm equipment.

2.2.4. Low-pressure CO₂ system

Where a low pressure CO₂ system is fitted to comply with this regulation, the following applies.

2.2.4.1. The system control devices and the refrigerating plants shall be located within the same room where the pressure vessels are stored.

2.2.4.2. The rated amount of liquid carbon dioxide shall be stored in vessel(s) under the working pressure in the range of 1.8 N/mm² to 2.2 N/mm². The normal liquid charge in the container shall be limited to provide sufficient vapour space to allow for expansion of the liquid under the maximum storage temperatures than can be obtained corresponding to the setting of the pressure relief valves but shall not exceed 95% of the volumetric capacity of the container.

2.2.4.3. Provision shall be made for:

- .1. pressure gauge;
- .2. high pressure alarm: not more than setting of the relief valve;
- .3. low pressure alarm: not less than 1.8 N/mm²;
- .4. branch pipes with stop valves for filling the vessel;
- .5. discharge pipes;
- .6. liquid CO₂ level indicator, fitted on the vessel(s); and
- .7. two safety valves.

2.2.4.4. The two safety relief valves shall be arranged so that either valve can be shut off while the other is connected to the vessel. The setting of the relief valves shall not be less than 1.1 times working pressure. The capacity of each valve shall be such that the vapours generated under fire condition can be discharged with a pressure rise not more than 20% above the setting pressure. The discharge from the safety valves shall be led to the open.

2.2.4.5. The vessel(s) and outgoing pipes permanently filled with carbon dioxide shall have thermal insulation preventing the operation of the safety valve in 24 h after de-energizing the plant, at ambient temperature of 45°C and an initial pressure equal to the starting pressure of the refrigeration unit.

2.2.4.6. The vessel(s) shall be serviced by two automated completely independent refrigerating units solely intended for this purpose, each comprising a compressor and the relevant prime mover, evaporator and condenser.

2.2.4.7. The refrigerating capacity and the automatic control of each unit shall be so as to maintain the required temperature under conditions of continuous operation during 24 h at sea temperatures up to 32°C and ambient air temperatures up to 45°C.

2.2.4.8. Each electric refrigerating unit shall be supplied from the main switchboard busbars by a separate feeder.

2.2.4.9. Cooling water supply to the refrigerating plant (where required) shall be provided from at least two circulating pumps one of which being used as a stand-by. The stand-by pump may be a pump used for other services so long as its use for cooling would not interfere with any other essential service of the ship. Cooling water shall be taken from not less than two sea connections, preferably one port and one starboard.

2.2.4.10. Safety relief devices shall be provided in each section of pipe that may be isolated by block valves and in which there could be a build-up of pressure in excess of the design pressure of any of the components.

2.2.4.11. Audible and visual alarms shall be given in a central control station or, in accordance with regulation II-1/51, where a central control station is not provided, when:

- .1. the pressure in the vessel(s) reaches the low and high values according to paragraph 2.2.4.2;
- .2. any one of the refrigerating units fails to operate; or
- .3. the lowest permissible level of the liquid in the vessels is reached.

2.2.4.12. If the system serves more than one space, means for control of discharge quantities of CO₂ shall be provided, e.g. automatic timer or accurate level indicators located at the control position(s).

2.2.4.13. If a device is provided which automatically regulates the discharge of the rated quantity of carbon dioxide into the protected spaces, it shall be also possible to regulate the discharge manually.

2.3 Requirements of steam systems

. The boiler or boilers available for supplying steam shall have an evaporation of at least 1 kg of steam per hour for each 0.75 m³ of the gross volume of the largest space so protected. In addition to complying with the foregoing requirements, the systems in all respects shall be as determined by, and to the satisfaction of, the Administration.

2.4 Equivalent fixed gas fire-extinguishing systems for machinery spaces and cargo pump-rooms

. Fixed gas fire-extinguishing systems equivalent to those specified in paragraphs 2.2 to 2.3 shall be approved by the Administration based on the guidelines developed by the Organization. ^{see footnote}

FSS Code - Fire Safety Systems – Resolution MSC.98(73) - Annex - International Code For Fire Safety Systems - Chapter 6 - Fixed Foam Fire-Extinguishing Systems

Chapter 6 - Fixed Foam Fire-Extinguishing Systems

1 Application

. This chapter details the specifications for fixed foam fire-extinguishing systems for the protection of machinery spaces in accordance with regulation II-2/10.4.1.1.2 of the Convention, cargo spaces in accordance with regulation II-2/10.7.1.1, cargo pump-rooms in accordance with regulation II-2/10.9.1.2 and vehicle, special category and ro-ro spaces in accordance with regulation II-2/20.6.1.3. This chapter does not apply to cargo pump-rooms of chemical tankers carrying liquid cargoes referred to in regulation II-2/1.6.2 of the Convention, unless the Administration specifically accepts the use of these systems based on additional tests with alcohol-based fuel and alcohol resistant foam. Unless expressly provided otherwise, the requirements of this chapter shall apply to ships constructed on or after 1 January 2014.

2 Definitions

2.1. *Design filling rate* is at least the minimum nominal filling rate used during the approval tests.

2.2. *Foam* is the extinguishing medium produced when foam solution passes through a foam generator and is mixed with air.

2.3. *Foam solution* is a solution of foam concentrate and water.

2.4. *Foam concentrate* is a liquid which, when mixed with water in the appropriate concentration forms a foam solution.

2.5. *Foam delivery ducts* are supply ducts for introducing high-expansion foam into the protected space from foam generators located outside the protected space.

2.6. *Foam mixing ratio* is the percentage of foam concentrate mixed with water forming the foam solution.

2.7. *Foam generators* are discharge devices or assemblies through which high-expansion foam solution is aerated to form foam that is discharged into the protected space. Foam generators using inside air typically consist of a nozzle or set of nozzles and a casing. The casing is typically made of perforated steel/stainless steel plates shaped into a box that enclose the nozzle(s). Foam generators using outside air typically consist of nozzles enclosed within a casing that spray onto a screen. An electric, hydraulic or pneumatically driven fan is provided to aerate the solution.

2.8. *High-expansion foam fire-extinguishing systems* are fixed total flooding extinguishing systems that use either inside air or outside air for aeration of the foam solution. A high-expansion foam system consists of both the foam generators and the dedicated foam concentrate approved during the fire testing specified in 3.1.3.

2.9. *Inside air foam system* is a fixed high-expansion foam fire-extinguishing system with foam generators located inside the protected space and drawing air from that space.

2.10. *Nominal flow rate* is the foam solution flow rate expressed in l/min.

2.11. *Nominal application rate* is the nominal flow rate per area expressed in l/min/m².

2.12. *Nominal foam expansion ratio* is the ratio of the volume of foam to the volume of foam solution from which it was made, under non-fire conditions, and at an ambient temperature of e.g. around 20°C.

2.13. *Nominal foam production* is the volume of foam produced per time unit, i.e. nominal flow rate times nominal foam expansion ratio, expressed in m³/min.

2.14. *Nominal filling rate* is the ratio of nominal foam production to the area, i.e. expressed in m²/min.

2.15. *Nominal filling time* is the ratio of the height of the protected space to the nominal filling rate, i.e. expressed in minutes.

2.16. *Outside air foam system* is a fixed high-expansion foam system with foam generators installed outside the protected space that are directly supplied with fresh air.

3 Fixed high-expansion foam fire-extinguishing systems

3.1 Principal performance

3.1.1. The system shall be capable of manual release, and shall be designed to produce foam at the required application rate within 1 minute of release. Automatic release of the system shall not be permitted unless appropriate operational measures or interlocks are provided to prevent any local application systems required by regulation II-2/10.5.6 of the Convention from interfering with the effectiveness of the system.

3.1.2. The foam concentrates shall be approved by the Administration based on the guidelines developed by the Organization ^{see footnote}. Different foam concentrate types shall not be mixed in a high-expansion foam system.

3.1.3. The system shall be capable of fire extinction and manufactured and tested to the satisfaction of the Administration based on the guidelines developed by the Organization ^{see footnote}.

3.1.4. The system and its components shall be suitably designed to withstand ambient temperature changes, vibration, humidity, shock, clogging and corrosion normally encountered on ships. Piping, fittings and related components inside the protected spaces (except gaskets) shall be designed to withstand 925°C.

3.1.5. System piping, foam concentrate storage tanks, components and pipe fittings in contact with the foam concentrate shall be compatible with the foam concentrate and be constructed of corrosion resistant materials such as stainless steel, or equivalent. Other system piping and foam generators shall be full galvanized steel or equivalent. Distribution pipework shall have self-draining capability.

3.1.6. Means for testing the operation of the system and assuring the required pressure and flow shall be provided by pressure gauges at both inlets (water and foam concentrate supply) and at the outlet of the foam proportioner. A test valve shall be installed on the distribution piping downstream of the foam proportioner, along with orifices which reflect the calculated pressure drop of the system. All sections of piping shall be provided with connections for flushing, draining and purging with air. All nozzles shall be able to be removed for inspection in order to prove clear of debris.

3.1.7. Means shall be provided for the crew to safely check the quantity of foam concentrate and take periodic control samples for foam quality.

3.1.8. Operating instructions for the system shall be displayed at each operating position.

3.1.9. Spare parts shall be provided based on the manufacturer's instruction.

3.1.10. If an internal combustion engine is used as a prime mover for the seawater pump for the system, the fuel oil tank to the prime mover shall contain sufficient fuel to enable the pump to run on full load for at least 3 h and sufficient reserves of fuel shall be available outside the machinery space of category A to enable the pump to be run on full load for an additional 15 h. If the fuel tank serves other internal combustion engines simultaneously, the total fuel tank capacity shall be adequate for all connected engines.

3.1.11. The arrangement of foam generators and piping in the protected space shall not interfere with access to the installed machinery for routine maintenance activities.

3.1.12. The system source of power supply, foam concentrate supply and means of controlling the system shall be readily accessible and simple to operate, and shall be arranged at positions outside the protected space not likely to be cut off by a fire in the protected space. All electrical components directly connected to the foam generators shall have at least an IP 54 rating.

3.1.13. The piping system shall be sized in accordance with a hydraulic calculation technique ^{see footnote} to ensure availability of flows and pressures required for correct performance of the system.

3.1.14. The arrangement of the protected spaces shall be such that they may be ventilated as the space is being filled with foam. Procedures shall be provided to ensure that upper level dampers, doors and other suitable openings are kept open in case of a fire. For inside air foam systems, spaces below 500 m³ need not comply with this requirement.

3.1.15. Onboard procedures shall be established to require personnel re-entering the protected space after a system discharge to wear breathing apparatus to protect them from oxygen deficient air and products of combustion entrained in the foam blanket.

3.1.16. Installation plans and operating manuals shall be supplied to the ship and be readily available on board. A list or plan shall be displayed showing spaces covered and the location of the zone in respect of each section. Instructions for testing and maintenance shall be available on board.

3.1.17. All installation, operation and maintenance instructions/plans for the system shall be in the working language of the ship. If the working language of the ship is not English, French, nor Spanish, a translation into one of these languages shall be included.

3.1.18. The foam generator room shall be ventilated to protect against overpressure, and shall be heated to avoid the possibility of freezing.

3.1.19. The quantity of foam concentrate available shall be sufficient to produce a volume of foam equal to at least five times the volume of the largest protected space enclosed by steel bulkheads, at the nominal expansion ratio, or enough for 30 min of full operation for the largest protected space, whichever is greater.

3.1.20. Machinery spaces, cargo pump-rooms, vehicle spaces, ro-ro spaces and special category spaces shall be provided with audible and visual alarms within the protected space warning of the release of the system. The alarms shall operate for the length of time needed to evacuate the space, but in no case less than 20 s.

3.2 Inside air foam systems

3.2.1 Systems for the protection of machinery spaces and cargo pump-rooms

3.2.1.1. The system shall be supplied by both main and emergency sources of power. The emergency power supply shall be provided from outside the protected space.

3.2.1.2. Sufficient foam-generating capacity shall be provided to ensure the minimum design filling rate for the system is met and in addition shall be adequate to completely fill the largest protected space within 10 min.

3.2.1.3. The arrangement of foam generators shall in general be designed based on the approval test results. A minimum of two generators shall be installed in every space containing combustion engines, boilers, purifiers, and similar equipment. Small workshops and similar spaces may be covered with only one foam generator.

3.2.1.4. Foam generators shall be uniformly distributed under the uppermost ceiling in the protected spaces including the engine casing. The number and location of foam generators shall be adequate to ensure all high risk areas are protected in all parts and at all levels of the spaces. Extra foam generators may be required in obstructed locations. The foam generators shall be arranged with at least 1 m free space in front of the foam outlets, unless tested with less clearance. The generators shall be located behind main structures, and above and away from engines and boilers in positions where damage from an explosion is unlikely.

3.2.2 Systems for the protection of vehicle, ro-ro, special category and cargo spaces

3.2.2.1. The system shall be supplied by the ship's main power source. An emergency power supply is not required.

3.2.2.2. Sufficient foam-generating capacity shall be provided to ensure the minimum design filling rate for the system is met and in addition shall be adequate to completely fill the largest protected space within 10 min. However, for systems protecting vehicle and ro-ro spaces and special category spaces, with decks that are reasonably gas-tight and that have a deck height of 3 m or less, the filling rate shall be not less than two thirds of the design filling rate and in addition sufficient to fill the largest protected space within 10 min.

3.2.2.3. The system may be divided into sections, however, the capacity and design of the system shall be based on the protected space demanding the greatest volume of foam. Adjacent protected spaces need not be served simultaneously if the boundaries between the spaces are "A" class divisions.

3.2.2.4. The arrangement of foam generators shall in general be designed based on the approval test results. The number of generators may be different, but the minimum design filling rate determined during approval testing shall be provided by the system. A minimum of two generators shall be installed in every space. The foam generators shall be arranged to uniformly distribute foam in the protected spaces, and the layout shall take into consideration obstructions that can be expected when cargo is loaded on board. As a minimum, generators shall be located on every second deck, including movable decks. The horizontal spacing of the generators shall ensure rapid supply of foam to all parts of the protected space. This shall be established on the basis of full scale tests.

3.2.2.5. The foam generators shall be arranged with at least 1 m free space in front of the foam outlets, unless tested with less clearance.

3.3 Outside air foam systems

3.3.1 Systems for the protection of machinery spaces and cargo pump-rooms

3.3.1.1. The system shall be supplied by both main and emergency sources of power. The emergency power supply shall be provided from outside the protected machinery space.

3.3.1.2. Sufficient foam-generating capacity shall be provided to ensure the minimum design filling rate for the system is met and in addition shall be adequate to completely fill the largest protected space within 10 min.

3.3.1.3. The arrangement of foam delivery ducts shall in general be designed based on the approval test results. The number of ducts may be different, but the minimum design filling rate determined during approval testing shall be provided by the system. A minimum of two ducts shall be installed in every space containing combustion engines, boilers, purifiers, and similar equipment. Small workshops and similar spaces may be covered with only one duct.

3.3.1.4. Foam delivery ducts shall be uniformly distributed under the uppermost ceiling in the protected spaces including the engine casing. The number and location of ducts shall be adequate to ensure all high risk areas are protected in all parts and at all levels of the spaces. Extra ducts may be required in obstructed locations. The ducts shall be arranged with at least 1 m free space in front of the foam delivery ducts, unless tested with less clearance. The ducts shall be located behind main structures, and above and away from engines and boilers in positions where damage from an explosion is unlikely.

3.3.1.5. The arrangement of the foam delivery ducts shall be such that a fire in the protected space will not affect the foam-generating equipment. If the foam generators are located adjacent to the protected space, foam delivery ducts shall be installed to allow at least 450 mm of separation between the generators and the protected space, and the separating divisions shall be class "A-60" rated. Foam delivery ducts shall be constructed of steel having a thickness of not less than 5 mm. In addition, stainless steel dampers (single or multi-bladed) with a thickness of not less than 3 mm shall be installed at the openings in the boundary bulkheads or decks between the foam generators and the protected space. The dampers shall be automatically operated (electrically, pneumatically or hydraulically) by means of remote control of the foam generator related to them, and arranged to remain closed until the foam generators begin operating.

3.3.1.6. The foam generators shall be located where an adequate fresh air supply can be arranged.

3.3.2 Systems for the protection of vehicle and ro-ro spaces and special category and cargo spaces

3.3.2.1. The system shall be supplied by the ship's main power source. An emergency power supply is not required.

3.3.2.2. Sufficient foam-generating capacity shall be provided to ensure the minimum design filling rate for the system is met and in addition shall be adequate to completely fill the largest protected space within 10 min. However, for systems protecting vehicle and ro-ro spaces and special category spaces, with decks that are reasonably gas-tight and that have a deck height of 3 m or less, the filling rate shall be not less than two thirds of the design filling rate and in addition sufficient to fill the largest protected space within 10 min.

3.3.2.3. The system may be divided into sections, however, the capacity and design of the system shall be based on the protected space demanding the greatest volume of foam. Adjacent protected spaces need not be served simultaneously if the boundaries between the spaces are "A" class divisions.

3.3.2.4. The arrangement of foam delivery ducts shall in general be designed based on the approval test results. The number of ducts may be different, but the minimum design filling rate determined during approval testing shall be provided by the system. A minimum of two ducts shall be installed in every space. The foam generators shall be arranged to uniformly distribute foam in the protected spaces, and the layout shall take into consideration obstructions that can be expected when cargo is loaded on board. As a minimum, ducts shall be led to every second deck, including movable decks. The horizontal spacing of the ducts shall ensure rapid supply of foam to all parts of the protected space. This shall be established on the basis of full scale tests.

3.3.2.5. The system shall be arranged with at least 1 m free space in front of the foam outlets, unless tested with less clearance.

3.3.2.6. The arrangement of the foam delivery ducts shall be such that a fire in the protected space will not affect the foam-generating equipment. If the foam generators are located adjacent to the protected space, foam delivery ducts shall be installed to allow at least 450 mm of separation between the generators and the protected space, and the separating divisions shall be class "A-60" rated. Foam delivery ducts shall be constructed of steel having a thickness of not less than 5 mm. In addition, stainless steel dampers (single or multi-bladed) with a thickness of not less than 3 mm shall be installed at the openings in the boundary bulkheads or decks between the foam generators and the protected space. The dampers shall be automatically operated (electrically, pneumatically or hydraulically) by means of remote control of the foam generator related to them, and arranged to remain closed until the foam generators begin operating.

3.3.2.7. The foam generators shall be located where an adequate fresh air supply can be arranged.

3.4 Installation testing requirements

3.4.1. After installation, the pipes, valves, fittings and assembled systems shall be tested to the satisfaction of the Administration, including functional testing of the power and control systems, water pumps, foam pumps, valves, remote and local release stations and alarms. Flow at the required pressure shall be verified for the system using orifices fitted to the test line. In addition, all distribution piping shall be flushed with freshwater and blown through with air to ensure that the piping is free of obstructions.

3.4.2. Functional tests of all foam proportioners or other foam mixing devices shall be carried out to confirm that the mixing ratio tolerance is within +30 to -0% of the nominal mixing ratio defined by the system approval. For foam proportioners using foam concentrates of Newtonian type with kinematic viscosity equal to or less than 100 cSt at 0°C and density equal to or less than 1,100 kg/m³, this test can be performed with water instead of foam concentrate. Other arrangements shall be tested with the actual foam concentrate.

3.5 Systems using outside air with generators installed inside the protected space

. Systems using outside air but with generators located inside the protected space and supplied by fresh air ducts may be accepted by the Administration provided that these systems have been shown to have performance and reliability equivalent to systems defined in 3.3. For acceptance, the Administration should consider the following minimum design features:

- .1. lower and upper acceptable air pressure and flow rate in supply ducts;
- .2. function and reliability of damper arrangements;
- .3. arrangements and distribution of air delivery ducts including foam outlets; and
- .4. separation of air delivery ducts from the protected space.

4 Fixed low-expansion foam fire-extinguishing systems

4.1 Quantity and foam concentrates

4.1.1. The foam concentrates of low-expansion foam fire-extinguishing systems shall be approved by the Administration based on the guidelines adopted by the Organization ^{see footnote}. Different foam concentrate types shall not be mixed in a low-expansion foam system. Foam concentrates of the same type from different manufacturers shall not be mixed unless they are approved for compatibility.

4.1.2. The system shall be capable of discharging through fixed discharge outlets, in no more than 5 min, a quantity of foam sufficient to produce an effective foam blanket over the largest single area over which oil fuel is liable to spread.

4.2 Installation requirements

4.2.1. Means shall be provided for effective distribution of the foam through a permanent system of piping and control valves or cocks to suitable discharge outlets, and for the foam to be effectively directed by fixed sprayers onto other main fire hazards in the protected space. The means for effective distribution of the foam shall be proven acceptable to the Administration through calculation or by testing.

4.2.2. The means of control of any such systems shall be readily accessible and simple to operate and shall be grouped together in as few locations as possible at positions not likely to be cut off by a fire in the protected space."

FSS Code - Fire Safety Systems – Resolution MSC.98(73) - Annex - International Code For Fire Safety Systems - Chapter 7 - Fixed Pressure Water-Spraying and Water-Mist Fire-Extinguishing Systems

Chapter 7 - Fixed Pressure Water-Spraying and Water-Mist Fire-Extinguishing Systems

1 Application

. This chapter details the specifications for fixed pressure water-spraying and water-mist fire-extinguishing systems as required by chapter II-2 of the Convention.

2 Engineering specifications

2.1 Fixed pressure water-spraying fire-extinguishing systems

. Fixed-pressure water-spraying fire-extinguishing systems for machinery spaces and cargo pump-rooms shall be approved by the Administration based on the guidelines developed by the Organization ^{see footnote} .

2.2 Equivalent water-mist fire-extinguishing systems

. Water-mist fire-extinguishing systems for machinery spaces and cargo pump-rooms shall be approved by the Administration based on the guidelines developed by the Organization ^{see footnote} ."

2.3 Fixed pressure water-spraying fire-extinguishing systems for cabin balconies

. Fixed pressure water-spraying fire-extinguishing systems for cabin balconies shall be approved by the Administration based on the guidelines developed by the Organization. ^{see footnote}

2.4 Fixed water-based fire-fighting systems for ro-ro spaces, vehicle spaces and special category spaces

. Fixed water-based fire-fighting systems for ro-ro spaces, vehicle spaces and special category spaces shall be approved by the Administration based on guidelines developed by the Organization ^{see footnote}

Chapter 8 - Automatic Sprinkler, Fire Detection and Fire Alarm Systems

1 Application

. This chapter details the specifications for automatic sprinkler, fire detection and fire alarm systems as required by chapter II-2 of the SOLAS Convention.

2 Engineering specifications

2.1 General

2.1.1. Type of sprinkler systems

The automatic sprinkler systems shall be of the wet pipe type, but small exposed sections may be of the dry pipe type where, in the opinion of the Administration, this is a necessary precaution. Control stations, where water may cause damage to essential equipment, may be fitted with a dry pipe system or a pre-action system as permitted by regulation II-2/10.6.1.1 of the Convention. Saunas shall be fitted with a dry pipe system, with sprinkler heads having an operating temperature up to 140° C.

2.1.2. Sprinkler systems equivalent to those specified in paragraphs 2.2 to 2.4

Automatic sprinkler systems equivalent to those specified in paragraphs 2.2 to 2.4 shall be approved by the Administration based on the guidelines developed by the Organization. ^{see footnote}

2.2 Sources of power supply

2.2.1. Passenger ships

There shall be not less than two sources of power supply for the sea water pump and automatic alarm and detection system. Where the sources of power for the pump are electrical, these shall be a main generator and an emergency source of power. One supply for the pump shall be taken from the main switchboard, and one from the emergency switchboard by separate feeders reserved solely for that purpose. The feeders shall be so arranged as to avoid galleys, machinery spaces and other enclosed spaces of high fire risk except in so far as it is necessary to reach the appropriate switchboards, and shall be run to an automatic changeover switch situated near the sprinkler pump. This switch shall permit the supply of power from the main switchboard so long as a supply is available therefrom, and be so designed that upon failure of that supply it will automatically change over to the supply from the emergency switchboard. The switches on the main switchboard and the emergency switchboard shall be clearly labelled and normally kept closed. No other switch shall be permitted in the feeders concerned. One of the sources of power supply for the alarm and detection system shall be an emergency source. Where one of the sources of power for the pump is an internal combustion engine it shall, in addition to complying with the provisions of paragraph 2.4.3, be so situated that a fire in any protected space will not affect the air supply to the machinery.

2.2.2. Cargo ships

There shall not be less than two sources of power supply for the seawater pump and automatic alarm and detection system. If the pump is electrically driven it shall be connected to the main source of electrical power, which shall be capable of being supplied by at least two generators. The feeders shall be so arranged as to avoid galleys, machinery spaces and other enclosed spaces of high fire risk except in so far as it is necessary to reach the appropriate switchboards. One of the sources of power supply for the alarm and detection system shall be an emergency source. Where one of the sources of power for the pump is an internal combustion engine it shall, in addition to complying with the provisions of paragraph 2.4.3, be so situated that a fire in any protected space will not affect the air supply to the machinery.

2.3 Component requirements

2.3.1. Sprinklers

2.3.1.1. The sprinklers shall be resistant to corrosion by the marine atmosphere. In accommodation and service spaces the sprinklers shall come into operation within the temperature range from 68° C to 79° C, except that in locations such as drying rooms, where high ambient temperatures might be expected, the operating temperature may be increased by not more than 30° C above the maximum deckhead temperature.

2.3.1.2. A quantity of spare sprinkler heads shall be provided for all types and ratings installed on the ship as follows:

Total number of heads	Required number of spares
<300	6
300 to 1000	12
>1000	24

The number of spare sprinkler heads of any type need not exceed the total number of heads installed of that type.

2.3.2. Pressure tanks

2.3.2.1. A pressure tank having a volume equal to at least twice that of the charge of water specified in this paragraph shall be provided. The tank shall contain a standing charge of fresh water, equivalent to the amount of water which would be discharged in one minute by the pump referred to in paragraph 2.3.3.2, and the arrangements shall provide for maintaining an air pressure in the tank such as to ensure that where the standing charge of fresh water in the tank has been used the pressure will be not less than the working pressure of the sprinkler, plus the pressure exerted by a head of water measured from the bottom of the tank to the highest sprinkler in the system. Suitable means of replenishing the air under pressure and of replenishing the fresh water charge in the tank shall be provided. A glass gauge shall be provided to indicate the correct level of the water in the tank.

2.3.2.2. Means shall be provided to prevent the passage of seawater into the tank.

2.3.3. Sprinkler pumps

2.3.3.1. An independent power pump shall be provided solely for the purpose of continuing automatically the discharge of water from the sprinklers. The pump shall be brought into action automatically by the pressure drop in the system before the standing fresh water charge in the pressure tank is completely exhausted.

2.3.3.2. The pump and the piping system shall be capable of maintaining the necessary pressure at the level of the highest sprinkler to ensure a continuous output of water sufficient for the simultaneous coverage of a minimum area of 280 m² at the application rate specified in paragraph 2.5.2.3. The hydraulic capability of the system shall be confirmed by the review of hydraulic calculations, followed by a test of the system, if deemed necessary by the Administration.

2.3.3.3. The pump shall have fitted on the delivery side a test valve with a short open-ended discharge pipe. The effective area through the valve and pipe shall be adequate to permit the release of the required pump output while maintaining the pressure in the system specified in paragraph 2.3.2.1.

2.4 Installation requirements

2.4.1. General

Any parts of the system which may be subjected to freezing temperatures in service shall be suitably protected against freezing.

2.4.2. Piping arrangements

2.4.2.1. Sprinklers shall be grouped into separate sections, each of which shall contain not more than 200 sprinklers. In passenger ships, any section of sprinklers shall not serve more than two decks and shall not be situated in more than one main vertical zone. However, the Administration may permit such a section of sprinklers to serve more than two decks or be situated in more than one main vertical zone, if it is satisfied that the protection of the ship against fire will not thereby be reduced.

2.4.2.2. Each section of sprinklers shall be capable of being isolated by one stop-valve only. The stop-valve in each section shall be readily accessible in a location outside of the associated section or in cabinets within stairway enclosures. The valve's location shall be clearly and permanently indicated. Means shall be provided to prevent the operation of the stop valves by any unauthorized person.

2.4.2.3. A test valve shall be provided for testing the automatic alarm for each section of sprinklers by a discharge of water equivalent to the operation of one sprinkler. The test valve for each section shall be situated near the stop-valve for that section.

2.4.2.4. The sprinkler system shall have a connection from the ship's fire main by way of a lockable screw-down non-return valve at the connection which will prevent a backflow from the sprinkler system to the fire main.

2.4.2.5. A gauge indicating the pressure in the system shall be provided at each section stop-valve and at a central station.

2.4.2.6. The sea inlet to the pump shall wherever possible be in the space containing the pump and shall be so arranged that when the ship is afloat it will not be necessary to shut off the supply of seawater to the pump for any purpose other than the inspection or repair of the pump.

2.4.3. Location of systems

The sprinkler pump and tank shall be situated in a position reasonably remote from any machinery space of category A and shall not be situated in any space required to be protected by the sprinkler system.

2.5 System control requirements

2.5.1. Ready availability

2.5.1.1. Any required automatic sprinkler, fire detection and fire alarm system shall be capable of immediate operation at all times and no action by the crew shall be necessary to set it in operation.

2.5.1.2. The automatic sprinkler system shall be kept charged at the necessary pressure and shall have provision for a continuous supply of water as required in this chapter.

2.5.2. Alarm and indication

2.5.2.1. Each section of sprinklers shall include means for giving a visual and audible alarm signal automatically at one or more indicating units whenever any sprinkler comes into operation. Such alarm systems shall be such as to indicate if any fault occurs in the system. Such units shall indicate in which section served by the system a fire has occurred and shall be centralised on the navigation bridge or in the continuously-manned central control station and, in addition, visible and audible alarms from the unit shall also be placed in a position other than on the aforementioned spaces to ensure that the indication of fire is immediately received by the crew.

2.5.2.2. Switches shall be provided at one of the indicating positions referred to in paragraph 2.5.2.1 which will enable the alarm and the indicators for each section of sprinklers to be tested.

2.5.2.3. Sprinklers shall be placed in an overhead position and spaced in a suitable pattern to maintain an average application rate of not less than 5 l/m²/min over the nominal area covered by the sprinklers. For this purpose, nominal area shall be taken as the gross horizontal projection of the area to be covered. However, the Administration may permit the use of sprinklers providing such an alternative amount of water suitably distributed as has been shown to the satisfaction of the Administration to be not less effective.

2.5.2.4. A list or plan shall be displayed at each indicating unit showing the spaces covered and the location of the zone in respect of each section. Suitable instructions for testing and maintenance shall be available.

2.5.3. Testing

Means shall be provided for testing the automatic operation of the pump on reduction of pressure in the system.

FSS Code - Fire Safety Systems – Resolution MSC.98(73) - Annex - International Code For Fire Safety Systems - Chapter 9 – Fixed fire detection and fire alarm systems

Chapter 9 – Fixed fire detection and fire alarm systems

1 Application

1.1. This chapter details the specification of fixed fire detection and fire alarm systems as required by chapter II-2 of the Convention. Unless expressly provided otherwise, the requirements of this chapter shall apply to ships constructed on or after 1 July 2012.

1.2 Definitions

1.2.1. *Section* means a group of fire detectors and manually operated call points as reported in the indicating unit(s).

1.2.2. *Section identification capability* means a system with the capability of identifying the section in which a detector or manually operated call point has activated.

1.2.3. *Individually identifiable* means a system with the capability to identify the exact location and type of detector or manually activated call point which has activated, and which can differentiate the signal of that device from all others.

2 Engineering specifications

2.1 General requirements

2.1.1. Any required fixed fire detection and fire alarm system with manually operated call points shall be capable of immediate operation at all times (this does not require a backup control panel). Notwithstanding this, particular spaces may be disconnected, for example, workshops during hot work and ro-ro spaces during on and off-loading. The means for disconnecting the detectors shall be designed to automatically restore the system to normal surveillance after a predetermined time that is appropriate for the

operation in question. The space shall be manned or provided with a fire patrol when detectors required by regulation are disconnected. Detectors in all other spaces shall remain operational.

2.1.2. The fire detection system shall be designed to:

- .1. control and monitor input signals from all connected fire and smoke detectors and manual call points;
- .2. provide output signals to the navigation bridge, continuously manned central control station or onboard safety centre to notify the crew of fire and fault conditions;
- .3. monitor power supplies and circuits necessary for the operation of the system for loss of power and fault conditions; and
- .4. the system may be arranged with output signals to other fire safety systems including:
 - .1. paging systems, fire alarm or public address systems;
 - .2. fan stops;
 - .3. fire doors;
 - .4. fire dampers;
 - .5. sprinkler systems;
 - .6. smoke extraction systems;
 - .7. low-location lighting systems;
 - .8. fixed local application fire-extinguishing systems;
 - .9. closed circuit television (CCTV) systems; and
 - .10. other fire safety systems.

2.1.3. The fire detection system may be connected to a decision management system provided that:

- .1. the decision management system is proven to be compatible with the fire detection system;
- .2. the decision management system can be disconnected without losing any of the functions required by this chapter for the fire detection system; and
- .3. any malfunction of the interfaced and connected equipment should not propagate under any circumstance to the fire detection system.

2.1.4. Detectors and manual call points shall be connected to dedicated sections of the fire detection system. Other fire safety functions, such as alarm signals from the sprinkler valves, may be permitted if in separate sections.

2.1.5. The system and equipment shall be suitably designed to withstand supply voltage variation and transients, ambient temperature changes, vibration, humidity, shock, impact and corrosion normally encountered in ships. All electrical and electronic equipment on the bridge or in the vicinity of the bridge shall be tested for electromagnetic compatibility, taking into account the recommendations developed by the Organization ^{see footnote}.

2.1.6. Fixed fire detection and fire alarm systems with individually identifiable fire detectors shall be so arranged that:

- .1. means are provided to ensure that any fault (e.g., power break, short circuit, earth, etc.) occurring in the section will not prevent the continued individual identification of the remainder of the connected detectors in the section;
- .2. all arrangements are made to enable the initial configuration of the system to be restored in the event of failure (e.g., electrical, electronic, informatics, etc.);
- .3. the first initiated fire alarm will not prevent any other detector from initiating further fire alarms; and
- .4. no section will pass through a space twice. When this is not practical (e.g., for large public spaces), the part of the section which by necessity passes through the space for a second time shall be installed at the maximum possible distance from the other parts of the section.

2.1.7. In passenger ships, the fixed fire detection and fire alarm system shall be capable of remotely and individually identifying each detector and manually operated call point. Fire detectors fitted in passenger ship cabins, when activated, shall also be capable of emitting, or cause to be emitted, an audible alarm within the space where they are located. In cargo ships and on passenger ship cabin balconies the fixed fire detection and fire alarm system shall, as a minimum, have section identification capability.

2.2 Sources of power supply

2.2.1. There shall be not less than two sources of power supply for the electrical equipment used in the operation of the fixed fire detection and fire alarm system, one of which shall be an emergency source of power. The supply shall be provided by separate feeders reserved solely for that purpose. Such feeders shall run to an automatic change-over switch situated in or adjacent to the control panel for the fire detection system. On ships constructed on or after 1 July 2014, the changeover switch shall be arranged

such that a fault will not result in the loss of both power supplies. The main (respective emergency) feeder shall run from the main (respective emergency) switchboard to the change-over switch without passing through any other distributing switchboard.

2.2.2. On ships constructed on or after 1 July 2014, the operation of the automatic changeover switch or a failure of one of the power supplies shall not result in loss of fire detection capability. Where a momentary loss of power would cause degradation of the system, a battery of adequate capacity shall be provided to ensure continuous operation during changeover.

2.2.3. There shall be sufficient power to permit the continued operation of the system with all detectors activated, but not more than 100 if the total exceeds this figure.

2.2.4. The emergency source of power specified in paragraph 2.2.1 above may be supplied by accumulator batteries or from the emergency switchboard. The power source shall be sufficient to maintain the operation of the fire detection and fire alarm system for the periods required under chapter II-1, regulations 42 and 43, of the Convention and, at the end of that period, shall be capable of operating all connected visual and audible fire alarm signals for a period of at least 30 min.

2.2.5. On ships constructed on or after 1 July 2014, where the system is supplied from accumulator batteries, they shall be located in or adjacent to the control panel for the fire detection system, or in another location suitable for use in an emergency. The rating of the battery charge unit shall be sufficient to maintain the normal output power supply to the fire detection system while recharging the batteries from a fully discharged condition.

2.3 Component requirements

2.3.1. Detectors

2.3.1.1. Detectors shall be operated by heat, smoke or other products of combustion, flame, or any combination of these factors. Detectors operated by other factors indicative of incipient fires may be considered by the Administration provided that they are no less sensitive than such detectors.

2.3.1.2. Smoke detectors required in all stairways, corridors and escape routes within accommodation spaces shall be certified to operate before the smoke density exceeds 12.5% obscuration per metre, but not until the smoke density exceeds 2% obscuration per metre, when tested according to standards EN 54:2001 and IEC 60092-504. Alternative testing standards may be used as determined by the Administration. Smoke detectors to be installed in other spaces shall operate within sensitivity limits to the satisfaction of the Administration having regard to the avoidance of detector insensitivity or oversensitivity.

2.3.1.3. Heat detectors shall be certified to operate before the temperature exceeds 78°C but not until the temperature exceeds 54°C, when the temperature is raised to those limits at a rate less than 1°C per min, when tested according to standards EN 54:2001 and IEC 60092-504. Alternative testing standards may be used as determined by the Administration. At higher rates of temperature rise, the heat detector shall operate within temperature limits to the satisfaction of the Administration having regard to the avoidance of detector insensitivity or oversensitivity.

2.3.1.4. The operation temperature of heat detectors in drying rooms and similar spaces of a normal high ambient temperature may be up to 130°C, and up to 140°C in saunas.

2.3.1.5. Flame detectors shall be tested according to standards EN 54-10:2001 and IEC 60092-504. Alternative testing standards may be used as determined by the Administration.

2.3.1.6. All detectors shall be of a type such that they can be tested for correct operation and restored to normal surveillance without the renewal of any component.

2.3.1.7. Fixed fire detection and fire alarm systems for cabin balconies shall be approved by the Administration, based on the guidelines developed by the Organization ^{see footnote}.

2.3.1.8. Detectors fitted in hazardous areas shall be tested and approved for such service. Detectors required by regulation II-2/20.4 and installed in spaces that comply with regulation II-2/20.3.2.2 of the Convention need not be suitable for hazardous areas. Detectors fitted in spaces carrying dangerous goods, required by regulation II-2/19, table 19.3, of the Convention to comply with regulation II-2/19.3.2 of the Convention, shall be suitable for hazardous areas.

2.3.2. Control panel

The control panel for the fire detection system shall be tested according to standards EN 54-2:1997, EN 54-4:1997 and IEC 60092-504:2001. Alternative standards may be used as determined by the Administration.

2.3.3. Cables

Cables used in the electrical circuits shall be flame retardant according to standard IEC 60332-1. On passenger ships, cables routed through other main vertical zones that they serve, and cables to control panels in an unattended fire control station shall be fire resisting according to standard IEC 60331, unless duplicated and well separated.

2.4 Installation requirements

2.4.1. Sections

2.4.1.1. Detectors and manually operated call points shall be grouped into sections.

2.4.1.2. A section of fire detectors which covers a control station, a service space or an accommodation space shall not include a machinery space of category A or a ro-ro space. A section of fire detectors which covers a ro-ro space shall not include a

machinery space of category A. For fixed fire detection systems with remotely and individually identifiable fire detectors, a section covering fire detectors in accommodation, service spaces and control stations shall not include fire detectors in machinery spaces of category A or ro-ro spaces.

2.4.1.3. Where the fixed fire detection and fire alarm system does not include means of remotely identifying each detector individually, no section covering more than one deck within accommodation spaces, service spaces and control stations shall normally be permitted except a section which covers an enclosed stairway. In order to avoid delay in identifying the source of fire, the number of enclosed spaces included in each section shall be limited as determined by the Administration. If the detection system is fitted with remotely and individually identifiable fire detectors, the sections may cover several decks and serve any number of enclosed spaces.

2.4.1.4. In passenger ships, a section of detectors and manually operated call points shall not be situated in more than one main vertical zone, except on cabin balconies.

2.4.2. Positioning of detectors

2.4.2.1. Detectors shall be located for optimum performance. Positions near beams and ventilation ducts, or other positions where patterns of air flow could adversely affect performance, and positions where impact or physical damage is likely, shall be avoided. Detectors shall be located on the overhead at a minimum distance of 0.5 m away from bulkheads, except in corridors, lockers and stairways.

2.4.2.2. The maximum spacing of detectors shall be in accordance with the table below:

Table 9.1 – Spacing of detectors

Type of detector	Maximum floor area per detector (m ²)	Maximum distance apart between centres (m)	Maximum distance away from bulkheads (m)
Heat	37	9	4.5
Smoke	74	11	5.5

. The Administration may require or permit other spacing based upon test data which demonstrate the characteristics of the detectors. Detectors located below moveable ro-ro decks shall be in accordance with the above.

2.4.2.3. Detectors in stairways shall be located at least at the top level of the stair and at every second level beneath.

2.4.2.4. When fire detectors are installed in freezers, drying rooms, saunas, parts of galleys used to heat food, laundries and other spaces where steam and fumes are produced, heat detectors may be used.

2.4.2.5. Where a fixed fire detection and fire alarm system is required by regulation II-2/7.5 of the Convention, spaces having little or no fire risk need not be fitted with detectors. Such spaces include void spaces with no storage of combustibles, private bathrooms, public toilets, fire-extinguishing medium storage rooms, cleaning gear lockers (in which flammable liquids are not stowed), open deck spaces and enclosed promenades having little or no fire risk and that are naturally ventilated by permanent openings.

2.4.3. Arrangement of cables

2.4.3.1. Cables which form part of the system shall be so arranged as to avoid galleys, machinery spaces of category A, and other enclosed spaces of high fire risk except where it is necessary to provide for fire detection or fire alarms in such spaces or to connect to the appropriate power supply.

2.4.3.2. A section with individually identifiable capability shall be arranged so that it cannot be damaged at more than one point by a fire.

2.5 System control requirements

2.5.1. Visual and audible fire signals see footnote

2.5.1.1. The activation of any detector or manually operated call point shall initiate a visual and audible fire detection alarm signal at the control panel and indicating units. If the signals have not been acknowledged within 2 min, an audible fire alarm shall be automatically sounded throughout the crew accommodation and service spaces, control stations and machinery spaces of category A. This alarm sounder system need not be an integral part of the detection system.

2.5.1.2. In passenger ships, the control panel shall be located in the onboard safety centre. In cargo ships, the control panel shall be located on the navigation bridge or in the fire control station.

2.5.1.3. In passenger ships, an indicating unit that is capable of individually identifying each detector that has been activated or manually operated call point that has operated shall be located on the navigation bridge. In cargo ships, an indicating unit shall be located on the navigation bridge if the control panel is located in the fire control station. In ships constructed on or after 1 July 2014, with a cargo control room, an additional indicating unit shall be located in the cargo control room. In cargo ships and on passenger cabin balconies, indicating units shall, as a minimum, denote the section in which a detector has activated or manually operated call point has operated.

2.5.1.4. Clear information shall be displayed on or adjacent to each indicating unit about the spaces covered and the location of the sections.

2.5.1.5. Power supplies and electric circuits necessary for the operation of the system shall be monitored for loss of power and fault conditions as appropriate including:

- .1. a single open or power break fault caused by a broken wire;
- .2. a single ground fault caused by the contact of a wiring conductor to a metal component; and
- .3. a single wire to wire fault caused by the contact of two or more wiring conductors.

. Occurrence of a fault condition shall initiate a visual and audible fault signal at the control panel which shall be distinct from a fire signal.

2.5.1.6. Means to manually acknowledge all alarm and fault signals shall be provided at the control panel. The audible alarm sounders on the control panel and indicating units may be manually silenced. The control panel shall clearly distinguish between normal, alarm, acknowledged alarm, fault and silenced conditions.

2.5.1.7. The system shall be arranged to automatically reset to the normal operating condition after alarm and fault conditions are cleared.

2.5.1.8. When the system is required to sound a local audible alarm within the cabins where the detectors are located, a means to silence the local audible alarms from the control panel shall not be permitted.

2.5.1.9. In general, audible alarm sound pressure levels at the sleeping positions in the cabins and 1 m from the source shall be at least 75 dB(A) and at least 10 dB(A) above ambient noise levels existing during normal equipment operation with the ship under way in moderate weather. The sound pressure level should be in the 1/3 octave band about the fundamental frequency. Audible alarm signals shall not exceed 120 dB(A).

2.5.2. Testing

. Suitable instructions and component spares for testing and maintenance shall be provided. Detectors shall be periodically tested using equipment suitable for the types of fires to which the detector is designed to respond. On ships constructed on or after 1 July 2014, detectors installed within cold spaces such as refrigerated compartments shall be tested using procedures having due regard for such locations. ^{see footnote} Ships with self-diagnostic systems that have in place a cleaning regime for areas where heads may be prone to contamination may carry out testing in accordance with the requirements of the Administration.

FSS Code - Fire Safety Systems – Resolution MSC.98(73) - Annex - International Code For Fire Safety Systems - Chapter 10 - Sample Extraction Smoke Detection Systems

Chapter 10 - Sample Extraction Smoke Detection Systems

1 Application

. This chapter details the specification of sample extraction smoke detection systems in cargo spaces as required by chapter II-2 of the Convention. Unless expressly provided otherwise, the requirements of this chapter shall apply to ships constructed on or after 1 January 2012.

2 Engineering Specifications

2.1 General requirements

2.1.1. Wherever in the text of this chapter the word "system" appears, it shall mean "sample extraction smoke detection system".

2.1.1.1. A sample extraction smoke detection system consists of the following main components:

.1. smoke accumulators: air collection devices installed at the open ends of the sampling pipes in each cargo hold that perform the physical function of collecting air samples for transmission to the control panel through the sampling pipes, and may also act as discharge nozzles for the fixed-gas fire-extinguishing system, if installed;

.2. sampling pipes: a piping network that connects the smoke accumulators to the control panel, arranged in sections to allow the location of the fire to be readily identified;

.3. three-way valves: if the system is interconnected to a fixed-gas fire-extinguishing system, three-way valves are used to normally align the sampling pipes to the control panel and, if a fire is detected, the three-way valves are re-aligned to connect the sampling pipes to the fire-extinguishing system discharge manifold and isolate the control panel; and

.4. control panel: the main element of the system which provides continuous monitoring of the protected spaces for indication of smoke. It typically may include a viewing chamber or smoke sensing units. Extracted air from the protected spaces is drawn through the smoke accumulators and sampling pipes to the viewing chamber, and then to the smoke sensing chamber where the airstream is monitored by electrical smoke detectors. If smoke is sensed, the repeater panel (normally on the bridge) automatically

sounds an alarm (not localized). The crew can then determine at the smoke sensing unit which cargo hold is on fire and operate the pertinent three-way valve for discharge of the extinguishing agent.

2.1.2. Any required system shall be capable of continuous operation at all times except that systems operating on a sequential scanning principle may be accepted, provided that the interval between scanning the same position twice gives a maximum allowable interval determined as follows:

The interval (I) should depend on the number of scanning points (N) and the response time of the fans (T), with a 20% allowance:

$$I = 1.2 \times T \times N$$

However, the maximum allowable interval should not exceed 120 s ($I_{\max} = 120$ s).

2.1.3. The system shall be designed, constructed and installed so as to prevent the leakage of any toxic or flammable substances or fire-extinguishing media into any accommodation space, service space, control station or machinery space.

2.1.4. The system and equipment shall be suitably designed to withstand supply voltage variations and transients, ambient temperature changes, vibration, humidity, shock, impact and corrosion normally encountered in ships and to avoid the possibility of ignition of a flammable gas-air mixture.

2.1.5. The system shall be of a type that can be tested for correct operation and restored to normal surveillance without the renewal of any component.

2.1.6. An alternative power supply for the electrical equipment used in the operation of the system shall be provided.

2.2 Component requirements

2.2.1. The sensing unit shall be certified to operate before the smoke density within the sensing chamber exceeds 6.65% obscuration per metre.

2.2.2. Duplicate sample extraction fans shall be provided. The fans shall be of sufficient capacity to operate with the normal conditions or ventilation in the protected area and the connected pipe size shall be determined with consideration of fan suction capacity and piping arrangement to satisfy the conditions of paragraph 2.4.2.2. Sampling pipes shall be a minimum of 12 mm internal diameter. The fan suction capacity should be adequate to ensure the response of the most remote area within the required time criteria in paragraph 2.4.2.2. Means to monitor airflow shall be provided in each sampling line.

2.2.3. The control panel shall permit observation of smoke in the individual sampling pipes.

2.2.4. The sampling pipes shall be so designed as to ensure that, as far as practicable, equal quantities of airflow are extracted from each interconnected accumulator.

2.2.5. Sampling pipes shall be provided with an arrangement for periodically purging with compressed air.

2.2.6. The control panel for the smoke detection system shall be tested according to standards EN 54-2 (1997), EN 54-4 (1997) and IEC 60092-504 (2001). Alternative standards may be used as determined by the Administration.

2.3 Installation requirements

2.3.1 Smoke accumulators

2.3.1.1. At least one smoke accumulator shall be located in every enclosed space for which smoke detection is required. However, where a space is designed to carry oil or refrigerated cargo alternatively with cargoes for which a smoke sampling system is required, means may be provided to isolate the smoke accumulators in such compartments for the system. Such means shall be to the satisfaction of the Administration.

2.3.1.2. Smoke accumulators shall be located on the overhead or as high as possible in the protected space, and shall be spaced so that no part of the overhead deck area is more than 12 m measured horizontally from an accumulator. Where systems are used in spaces which may be mechanically ventilated, the position of the smoke accumulators shall be considered having regard to the effects of ventilation. At least one additional smoke accumulator is to be provided in the upper part of each exhaust ventilation duct. An adequate filtering system shall be fitted at the additional accumulator to avoid dust contamination.

2.3.1.3. Smoke accumulators shall be positioned where impact or physical damage is unlikely to occur.

2.3.1.4. Sampling pipe networks shall be balanced to ensure compliance with paragraph 2.2.4. The number of accumulators connected to each sampling pipe shall ensure compliance with paragraph 2.4.2.2.

2.3.1.5. Smoke accumulators from more than one enclosed space shall not be connected to the same sampling pipe.

2.3.1.6. In cargo holds where non-gastight "tween deck panels" (movable stowage platforms) are provided, smoke accumulators shall be located in both the upper and lower parts of the holds.

2.3.2 Sampling pipes

2.3.2.1. The sampling pipe arrangements shall be such that the location of the fire can be readily identified.

2.3.2.2. Sampling pipes shall be self-draining and suitably protected from impact or damage from cargo working.

2.4 System control requirements

2.4.1 Visual and audible fire signals

2.4.1.1. The detection of smoke or other products of combustion shall initiate a visual and audible signal at the control panel and indicating units.

2.4.1.2. The control panel shall be located on the navigation bridge or in the fire control station. An indicating unit shall be located on the navigation bridge if the control panel is located in the fire control station.

2.4.1.3. Clear information shall be displayed on or adjacent to the control panel and indicating units designating the spaces covered.

2.4.1.4. Power supplies necessary for the operation of the system shall be monitored for loss of power. Any loss of power shall initiate a visual and audible signal at the control panel and the navigating bridge which shall be distinct from a signal indicating smoke detection.

2.4.1.5. Means to manually acknowledge all alarm and fault signals shall be provided at the control panel. The audible alarm sounders on the control panel and indicating units may be manually silenced. The control panel shall clearly distinguish between normal, alarm, acknowledged alarm, fault and silenced conditions.

2.4.1.6. The system shall be arranged to automatically reset to the normal operating condition after alarm and fault conditions are cleared.

2.4.2 Testing

2.4.2.1. Suitable instructions and component spares shall be provided for the testing and maintenance of the system.

2.4.2.2. After installation, the system shall be functionally tested using smoke generating machines or equivalent as a smoke source. An alarm shall be received at the control unit in not more than 180 s for vehicle decks, and not more than 300 s for container and general cargo holds, after smoke is introduced at the most remote accumulator.

FSS Code - Fire Safety Systems – Resolution MSC.98(73) - Annex - International Code For Fire Safety Systems - Chapter 11 - Low-location lighting systems

Chapter 11 - Low-location lighting systems

1 Application

. This chapter details the specifications for low-location lighting systems as required by chapter II-2 of the Convention.

2 Engineering specifications

2.1. General Requirements

Any required low-location lighting systems shall be approved by the Administration based on the guidelines developed by the Organization, ^{see footnote} or to an international standard acceptable to the Organization. ^{see footnote}

Chapter 12 - Fixed Emergency Fire Pumps

1 Application

. This chapter details the specifications for emergency fire pumps as required by chapter II-2 of the Convention. This chapter is not applicable to passenger ships of 1,000 gross tonnage and upwards. See regulation II-2/10.2.2.3.1.1 of the Convention for requirements for such ships.

2 Engineering specifications

2.1 General

. The emergency fire pump shall be of a fixed independently driven power-operated pump.

2.2 Component requirements

2.2.1. Emergency fire pumps

2.2.1.1. Capacity of the pump

The capacity of the pump shall not be less than 40% of the total capacity of the fire pumps required by regulation II-2/10.2.2.4.1 of the Convention and in any case not less than the following:

- .1 for passenger ships less than 1,000 gross tonnage and for cargo ships of 2,000 gross tonnage and upwards; and 25 m³/h
- .2 for cargo ships of less than 2,000 gross tonnage 15 m³/h

2.2.1.2. Pressure at hydrants

When the pump is delivering the quantity of water required by paragraph 2.2.1.1, the pressure at any hydrants shall be not less than the minimum pressure required by chapter II-2 of the Convention.

2.2.1.3. Suction heads

The total suction head and the net positive suction head of the pump shall be determined having due regard to the requirements of the Convention and this chapter on the pump capacity and on the hydrant pressure under all conditions of list, trim, roll and pitch likely to be encountered in service. The ballast condition of a ship on entering or leaving a dry dock need not be considered a service condition.

2.2.2. Diesel engines and fuel tank

2.2.2.1. Starting of diesel engine

Any diesel-driven power source for the pump shall be capable of being readily started in its cold condition down to the temperature of 0°C by hand (manual) cranking. Where ready starting cannot be assured, if this is impracticable, or if lower temperatures are likely to be encountered, and if the room for the diesel driven power source is not heated, electric heating of the diesel engine cooling water or lubricating oil system shall be fitted, to the satisfaction of the Administration. If hand (manual) starting is impracticable, the Administration may permit compressed air, electricity, or other sources of stored energy, including hydraulic power or starting cartridges to be used as a means of starting. These means shall be such as to enable the diesel-driven power source to be started at least six times within a period of 30 min and at least twice within the first 10 min

2.2.2.2. Fuel tank capacity

Any service fuel tank shall contain sufficient fuel to enable the pump to run on full load for at least 3 h and sufficient reserves of fuel shall be available outside the machinery space of category A to enable the pump to be run on full load for an additional 15 h.

Chapter 13 - Arrangement of Means of Escape

1 Application

. This chapter details the specifications for means of escape as required by chapter II-2 of the Convention.

2 Passenger Ships

2.1 Width of stairways

2.1.1 Basic requirements for stairway widths

. Stairways shall not be less than 900 mm in clear width. The minimum clear width of stairways shall be increased by 10 mm for every one person provided for in excess of 90 persons. The total number of persons to be evacuated by such stairways shall be assumed to be two thirds of the crew and the total number of passengers in the areas served by such stairways. The width of the stairways shall not be inferior to those determined by paragraph 2.1.2.

2.1.2 Calculation method of stairway widths

2.1.2.1. Basic principles of the calculation

2.1.2.1.1. This calculation method determines the minimum stairway width at each deck level, taking into account the consecutive stairways leading into the stairway under consideration.

2.1.2.1.2. It is the intention that the calculation method shall consider evacuation from enclosed spaces within each main vertical zone individually and take into account all of the persons using the stairway enclosures in each zone, even if they enter that stairway from another vertical zone.

2.1.2.1.3. For each main vertical zone the calculation shall be completed for the night time (case 1) and day time (case 2) and the largest dimension from either case used for determining the stairway width for each deck under consideration.

2.1.2.1.4. The calculation of stairway widths shall be based upon the crew and passenger load on each deck. Occupant loads shall be rated by the designer for passenger and crew accommodation spaces, service spaces, control spaces and machinery spaces. For the purpose of the calculation the maximum capacity of a public space shall be defined by either of the following two

values: the number of seats or similar arrangements, or the number obtained by assigning 2 m² of gross deck surface area to each person.

2.1.2.2. Calculation method for minimum value

2.1.2.2.1. Basic formulae

. In considering the design of stairway widths for each individual case which allow for the timely flow of persons evacuating to the assembly stations from adjacent decks above and below, the following calculation methods shall be used (see figures 1 and 2):

when joining two decks: $W = (N_1 + N_2) \times 10 \text{ mm};$

when joining three decks: $W = (N_1 + N_2 + 0.5N_3) \times 10 \text{ mm};$

when joining four decks: $W = (N_1 + N_2 + 0.5N_3 + 0.25N_4) \times 10 \text{ mm};$ and

when joining five decks or more decks, the width of the stairways shall be determined by applying the above formula for four decks to the deck under consideration and to the consecutive deck,

where:

W = the required tread width between handrails of the stairway.

The calculated value of W may be reduced where available landing area S is provided in stairways at the deck level defined by subtracting P from Z, such that:

$$P = S \times 3.0 \text{ persons/m}^2; \text{ and } P_{\text{max}} = 0.25Z$$

where:

Z = the total number of persons expected to be evacuated on the deck being considered

P = the number of persons taking temporary refuge on the stairway landing, which may be subtracted from Z to a maximum value of $P = 0.25Z$ (to be rounded down to the nearest whole number)

S = the surface area (m²) of the landing, minus the surface area necessary for the opening of doors and minus the surface area necessary for accessing the flow on stairs (see figure 1)

N = the total number of persons expected to use the stairway from each consecutive deck under consideration; N₁ is for the deck with the largest number of persons using that stairway; N₂ is taken for the deck with the next highest number of persons directly entering the stairway flow such that, when sizing the stairway width as each deck level, $N_1 > N_2 > N_3 > N_4$ (see figure 2). These decks are assumed to be on or upstream (i.e. away from the embarkation deck) of the deck being considered.

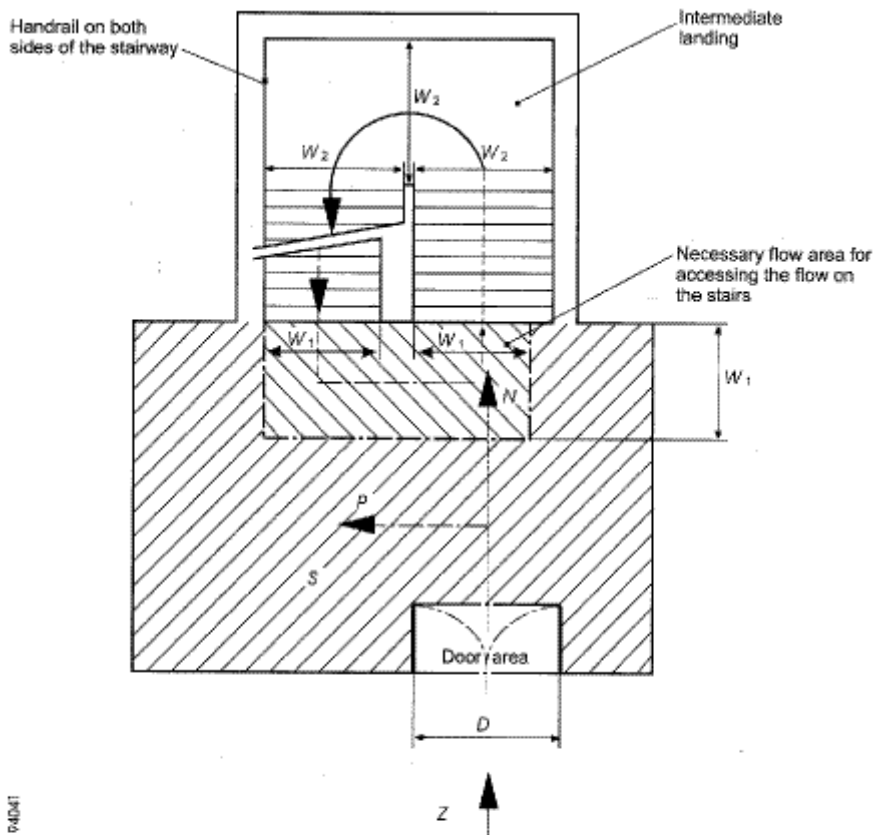

04/04/01

- $P = S \times 3 \text{ persons/m}^2 =$ the number of persons taking refuge on the landing to a maximum of $P = 0.25Z$;
- $N = Z - P =$ the number of persons directly entering the stairway flow from a given deck;
- $Z =$ number of persons to be evacuated from the deck considered;
- $S =$ available landing area (m^2) after subtracting the surface area necessary for movement and subtracting the space taken by the door swing area. Landing area is a sum of flow area, credit area and door area;
- $D =$ width of exit doors to the stairway landing area (mm)

Figure 1 Landing Calculation for Stairway Width Reduction

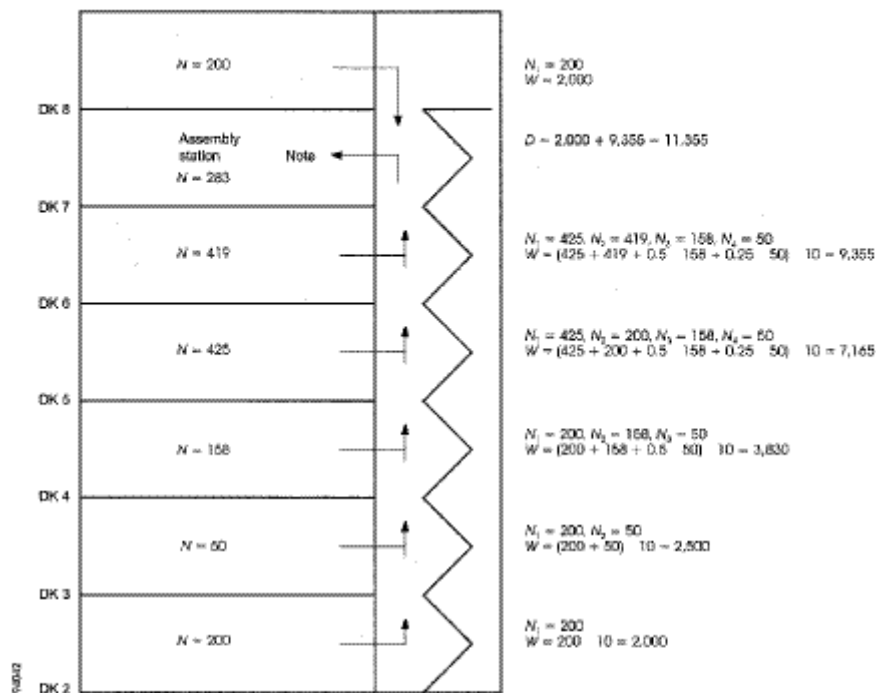

Z (pers) = number of persons expected to evacuate through the stairway

N (pers) = number of persons directly entering the stairway flow from a given deck

W (mm) = $(N_1 + N_2 + 0.5 \times N_3 + 0.25 \times N_4) \times 10$ = calculated width of stairway

D (mm) = width of exit doors

$N_1 > N_2 > N_3 > N_4$ where:

N₁ (pers) = the deck with the largest number of persons N entering directly the stairway

N₂ (pers) = the deck with the next largest number of persons N entering directly the stairway, etc.

Note: The doors to the assembly station shall have aggregate widths of 11,355 mm.

Figure 2 Minimum Stairway Width (W) Calculation Example

2.1.2.2.2. Distribution of persons

2.1.2.2.2.1. The dimension of the means of escape shall be calculated on the basis of the total number of persons expected to escape by the stairway and through doorways, corridors and landings (see figure 3). Calculations shall be made separately for the two cases of occupancy of the spaces specified below. For each component part of the escape route, the dimension taken shall not be less than the largest dimension determined for each case:

Case 1:	Passengers in cabins with maximum berthing capacity fully occupied; members of the crew in cabins occupied to 2/3 of maximum berthing capacity; and service spaces occupied by 1/3 of the crew.
Case 2:	Passengers in public spaces occupied to 3/4 of maximum capacity; members of the crew in public spaces occupied to 1/3 of the maximum capacity; service spaces occupied by 1/3 of the crew; and crew accommodation occupied by 1/3 of the crew.

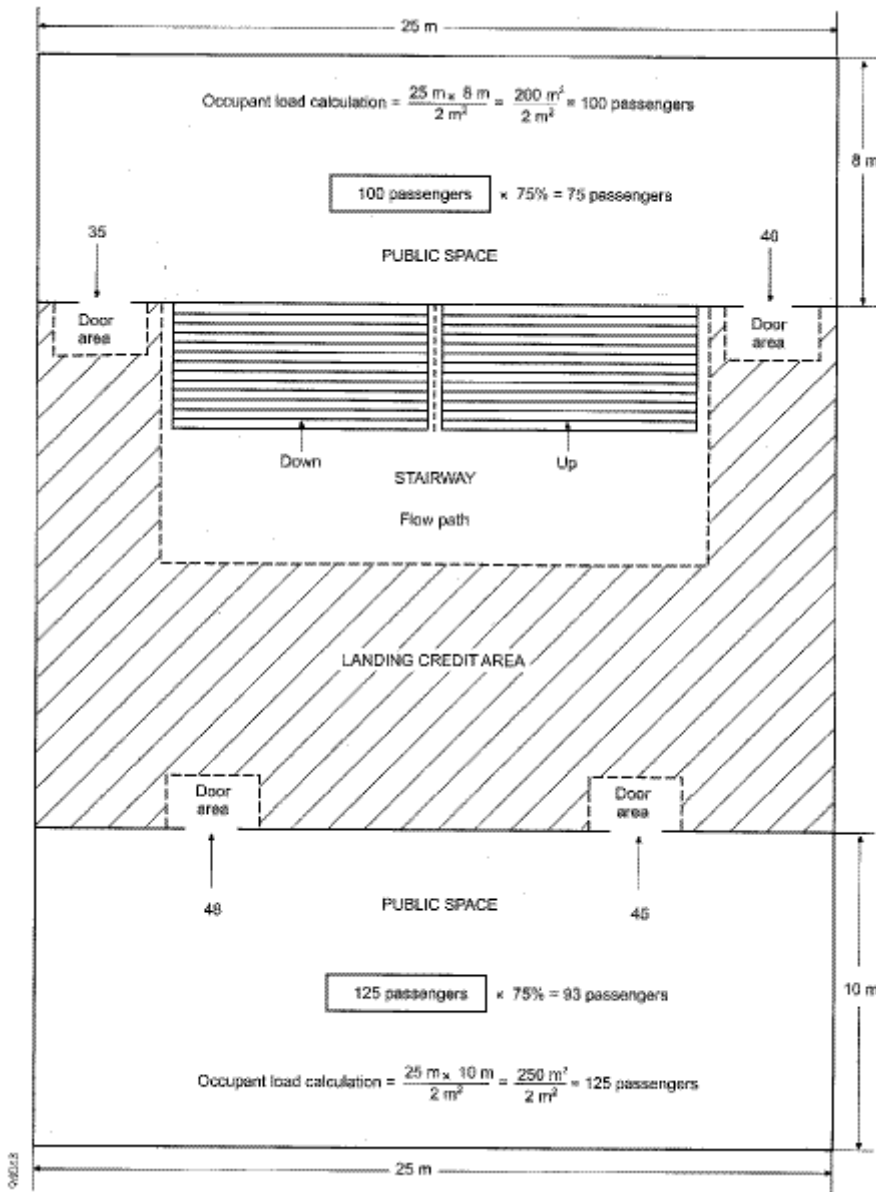

Figure 3 Occupant Loading Calculation

2.1.2.2.2.2. The maximum number of persons contained in a vertical zone, including persons entering stairways from another main vertical zone, shall not be assumed to be higher than the maximum number of persons authorized to be carried on board for the calculation of stairway widths only.

2.1.3 Prohibition of decrease in width in the direction to the assembly station ^{see footnote}

. The stairway shall not decrease in width in the direction of evacuation to the assembly station. Where several assembly stations are in one main vertical zone, the stairway width shall not decrease in the direction of the evacuation to the most distant assembly station.

2.2 Details of stairways

2.2.1. Handrails

Stairways shall be fitted with handrails on each side. The maximum clear width between handrails shall be 1,800 mm.

2.2.2. Alignment of stairways

All stairways sized for more than 90 persons shall be aligned fore and aft.

2.2.3. Vertical rise and inclination

Stairways shall not exceed 3.5 m in vertical rise without the provision of a landing and shall not have an angle of inclination greater than 45°.

2.2.4. Landings

With the exception of intermediate landings, landings at each deck level shall be not less than 2 m² in area and shall increase by 1 m² for every 10 persons provided for in excess of 20 persons, but need not exceed 16 m², except for those landings servicing public spaces having direct access onto the stairway enclosure. Intermediate landings shall be sized in accordance with paragraph 2.3.1.

2.3 Doorways and corridors

2.3.1. Doorways and corridors and intermediate landings included in means of escape shall be sized in the same manner as stairways.

2.3.2. The aggregate width of stairway exit doors to the assembly station shall not be less than the aggregate width of stairways serving this deck.

2.4 Evacuation routes to the embarkation deck

2.4.1. Assembly station

It shall be recognized that the evacuation routes to the embarkation deck may include an assembly station. In this case, consideration shall be given to the fire-protection requirements and sizing of corridors and doors from the stairway enclosure to the assembly station and from the assembly station to the embarkation deck, noting that evacuation of persons from assembly stations to embarkation positions will be carried out in small control groups.

2.4.2. Routes from the assembly station to the survival craft embarkation position

Where the passengers and crew are held at an assembly station which is not at the survival craft embarkation position, the dimension of stairway width and doors from the assembly station to this position shall be based on the number of persons in the controlled group. The width of these stairways and doors need not exceed 1,500 mm unless larger dimensions are required for evacuation of these spaces under normal conditions.

2.5 Means of escape plans

2.5.1. Means of escape plans shall be provided indicating the following:

- .1. the number of the crew and passengers in all normally occupied spaces;
- .2. the number of crew and passengers expected to escape by stairway and through doorways, corridors and landings;
- .3. assembly stations and survival craft embarkation positions;
- .4. primary and secondary means of escape; and
- .5. width of stairways, doors, corridors and landing areas.

2.5.2. Means of escape plans shall be accompanied by detailed calculations for determining the width of escape stairways, doors, corridors and landing areas.

3 Cargo ships

. Stairways and corridors used as means of escape shall be not less than 700 mm in clear width and shall have a handrail on one side. Stairways and corridors with a clear width of 1,800 mm and over shall have handrails on both sides. "Clear width" is considered the distance between the handrail and the bulkhead on the other side or between the handrails. The angle of inclination of stairways should be, in general, 45°, but not greater than 50°, and in machinery spaces and small spaces not more than 60°. Doorways which give access to a stairway shall be of the same size as the stairway.

Chapter 14 - Fixed Deck Foam Systems

1 Application

1.1. This chapter details the specification of fixed deck foam systems which are required to be provided by chapter II-2 of the Convention.

2 Engineering specifications

2.1 General

2.1.1. The arrangements for providing foam shall be capable of delivering foam to the entire cargo tanks deck area as well as into any cargo tank the deck of which has been ruptured.

2.1.2. The deck foam system shall be capable of simple and rapid operation.

2.1.3. Operation of a deck foam system at its required output shall permit the simultaneous use of the minimum required number of jets of water at the required pressure from the fire main. Where the deck foam system is supplied by a common line from the fire main, additional foam concentrate shall be provided for operation of two nozzles for the same period of time required for the foam system. The simultaneous use of the minimum required jets of water shall be possible on deck over the full length of the ship, in the accommodation, service spaces, control stations and machinery spaces.

2.2 Component requirements

2.2.1 Foam solution and foam concentrate

2.2.1.1. For tankers carrying:

.1. crude oil or petroleum products having a flashpoint not exceeding 60°C (closed cup), as determined by an approved flashpoint apparatus, and a Reid vapour pressure which is below atmospheric pressure or other liquid products having a similar fire hazard, including cargoes in chapter 18 of the IBC Code, having a flashpoint not exceeding 60°C (closed cup) for which a regular foam fire-fighting system is effective (refer to regulations II-2/1.6.1 and 10.8 of the Convention); or

.2. petroleum products with a flashpoint exceeding 60°C (closed cup), as determined by an approved flashpoint apparatus (refer to regulation II-2/1.6.4 of the Convention); or

.3. IBC Code chapter 17 products with a flashpoint exceeding 60°C (closed cup) determined by an approved flashpoint apparatus (refer to paragraph 11.1.3 of the IBC Code and regulation II-2/1.6.4 of the Convention),

the rate of supply of foam solution shall be not less than the greatest of the following:

.1. 0.6 l/min per square metre of cargo tanks deck area, where cargo tanks deck area means the maximum breadth of the ship multiplied by the total longitudinal extent of the cargo tank spaces;

.2. 6 l/min per square metre of the horizontal sectional area of the single tank having the largest such area; or

.3. 3 l/min per square metre of the area protected by the largest monitor, such area being entirely forward of the monitor, but in no case should the output of any monitor be less than 1,250 l/min.

2.2.1.2. For tankers carrying chemicals in bulk listed in chapter 17 of the IBC Code having a flashpoint not exceeding 60°C (closed cup), the rate of supply of foam solution shall be as required by the IBC Code.

2.2.1.3. Sufficient foam concentrate shall be supplied to ensure at least 20 min of foam generation in tankers fitted with an inert gas installation or 30 min of foam generation in tankers not fitted with an inert gas installation or not required to use an inert gas system.

2.2.1.4. The foam concentrate supplied on board shall be approved by the Administration ^{see footnote} for the cargoes intended to be carried. Type B foam concentrates shall be supplied for the protection of crude oil, petroleum products and non-polar solvent cargoes. Type A foam concentrates shall be supplied for polar solvent cargoes, as listed in the table of chapter 17 of the IBC Code. Only one type of foam concentrate shall be supplied, and it shall be effective for the maximum possible number of cargoes intended to be carried. For cargoes for which foam is not effective or is incompatible, additional arrangements to the satisfaction of the Administration shall be provided.

2.2.1.5. Liquid cargoes with a flashpoint not exceeding 60°C for which a regular foam fire-fighting system is not effective shall comply with the provisions of regulation II-2/1.6.2.1 of the Convention.

2.2.2 Monitors and foam applicators

2.2.2.1. Foam from the fixed foam system shall be supplied by means of monitors and foam applicators. Prototype tests of the monitors and foam applicators shall be performed to ensure the foam expansion and drainage time of the foam produced does not differ more than ± 10 per cent of that determined in paragraph 2.2.1.4. When medium expansion ratio foam (between 21 to 1 and 200 to 1 expansion ratio) is employed, the application rate of the foam and the capacity of a monitor installation shall be to the satisfaction of the Administration. At least 50 per cent of the foam solution supply rate required shall be delivered from each monitor. On tankers of less than 4,000 tonnes deadweight the Administration may not require installation of monitors but only applicators. However, in such a case the capacity of each applicator shall be at least 25 per cent of the foam solution supply rate required.

2.2.2.2. The capacity of any applicator shall be not less than 400 l/min and the applicator throw in still air conditions shall be not less than 15 m.

2.3 Installation requirements

2.3.1 Main control station

2.3.1.1. The main control station for the system shall be suitably located outside the cargo area, adjacent to the accommodation spaces and readily accessible and operable in the event of fire in the areas protected.

2.3.2 Monitors

2.3.2.1. The number and position of monitors shall be such as to comply with paragraph 2.1.1.

2.3.2.2. The distance from the monitor to the farthest extremity of the protected area forward of that monitor shall not be more than 75 per cent of the monitor throw in still air conditions.

2.3.2.3. A monitor and hose connection for a foam applicator shall be situated both port and starboard at the front of the poop or accommodation spaces facing the cargo tanks deck. The monitors and hose connections shall be aft of any cargo tanks, but may be located in the cargo area above pump-rooms, cofferdams, ballast tanks and void spaces adjacent to cargo tanks if capable of protecting the deck below and aft of each other. On tankers of less than 4,000 tonnes deadweight a hose connection for a foam applicator shall be situated both port and starboard at the front of the poop or accommodation spaces facing the cargo tanks deck.

2.3.3 Applicators

2.3.3.1. At least four foam applicators shall be provided on all tankers. The number and disposition of foam main outlets shall be such that foam from at least two applicators can be directed on to any part of the cargo tanks deck area.

2.3.3.2. Applicators shall be provided to ensure flexibility of action during fire-fighting operations and to cover areas screened from the monitors.

2.3.4 Isolation valves

2.3.4.1. Valves shall be provided in the foam main, and in the fire main when this is an integral part of the deck foam system, immediately forward of any monitor position to isolate damaged sections of those mains."

FSS Code - Fire Safety Systems – Resolution MSC.98(73) - Annex - International Code For Fire Safety Systems - Chapter 15 - Inert Gas Systems

Chapter 15 - Inert Gas Systems

1 Application

. This chapter details the specifications for inert gas systems as required by chapter II-2 of the Convention.

2 Engineering specifications

2.1 General

2.1.1. Throughout this chapter the term cargo tank includes also slop tanks.

2.1.2. The inert gas system referred to in chapter II-2 of the Convention shall be designed, constructed and tested to the satisfaction of the Administration. It shall be so designed ^{see footnote} and operated as to render and maintain the atmosphere of the cargo tanks non-flammable at all times, except when such tanks are required to be gas-free. In the event that the inert gas system is unable to meet the operational requirement set out above and it has been assessed that it is impracticable to effect a repair, then cargo discharge, deballasting and necessary tank cleaning shall only be resumed when the "emergency conditions" specified in the Guidelines on inert gas systems are complied with. ^{see footnote}

2.1.3. Required functions

The system shall be capable of:

- .1. inerting empty cargo tanks by reducing the oxygen content of the atmosphere in each tank to a level at which combustion cannot be supported;
- .2. maintaining the atmosphere in any part of any cargo tank with an oxygen content not exceeding 8% by volume and at a positive pressure at all times in port and at sea except when it is necessary for such a tank to be gas-free;
- .3. eliminating the need for air to enter a tank during normal operations except when it is necessary for such a tank to be gas-free; and
- .4. purging empty cargo tanks of a hydrocarbon gas, so that subsequent gas-freeing operations will at no time create a flammable atmosphere within the tank.

2.2 Component requirements

2.2.1 Supply of inert gas

2.2.1.1. The inert gas supply may be treated flue gas from main or auxiliary boilers. The Administration may accept systems using flue gases from one or more separate gas generators or other sources or any combination thereof, provided that an equivalent standard of safety is achieved. Such systems shall, as far as practicable, comply with the requirements of this chapter. Systems using stored carbon dioxide shall not be permitted unless the Administration is satisfied that the risk of ignition from generation of static electricity by the system itself is minimized.

2.2.1.2. The system shall be capable of delivering inert gas to the cargo tanks at a rate of at least 125% of the maximum rate of discharge capacity of the ship expressed as a volume.

2.2.1.3. The system shall be capable of delivering inert gas with an oxygen content of not more than 5 % by volume in the inert gas supply main to the cargo tanks at any required rate of flow.

2.2.1.4. Two fuel oil pumps shall be fitted to the inert gas generator. The Administration may permit only one fuel oil pump on condition that sufficient spares for the fuel oil pump and its prime mover are carried on board to enable any failure of the fuel oil pump and its prime mover to be rectified by the ship's crew.

2.2.2 Scrubbers

2.2.2.1. A flue gas scrubber shall be fitted which will effectively cool the volume of gas specified in paragraphs 2.2.1.2 and 2.2.1.3 and remove solids and sulphur combustion products. The cooling water arrangements shall be such that an adequate supply of water will always be available without interfering with any essential services on the ship. Provision shall also be made for an alternative supply of cooling water.

2.2.2.2. Filters or equivalent devices shall be fitted to minimize the amount of water carried over to the inert gas blowers.

2.2.2.3. The scrubber shall be located aft of all cargo tanks, cargo pump-rooms and cofferdams separating these spaces from machinery spaces of category A.

2.2.3 Blowers

2.2.3.1. At least two blowers shall be fitted and be capable of delivering to the cargo tanks at least the volume of gas required by paragraphs 2.2.1.2 and 2.2.1.3. For systems with gas generators, the Administration may permit only one blower if that system is capable of delivering the total volume of gas required by paragraphs 2.2.1.2 and 2.2.1.3 to the protected cargo tanks, provided that sufficient spares for the blower and its prime mover are carried on board to enable any failure of the blower and its prime mover to be rectified by the ship's crew.

2.2.3.2. The inert gas system shall be so designed that the maximum pressure which it can exert on any cargo tank will not exceed the test pressure of any cargo tank. Suitable shutoff arrangements shall be provided on the suction and discharge connections of each blower. Arrangements shall be provided to enable the functioning of the inert gas plant to be stabilized before commencing cargo discharge. If the blowers are to be used for gas-freeing, their air inlets shall be provided with blanking arrangements.

2.2.3.3. The blowers shall be located aft of all cargo tanks, cargo pump-rooms and cofferdams separating these spaces from machinery spaces of category A.

2.2.4 Water seals

2.2.4.1. The water seal referred to in paragraph 2.3.1.4.1 shall be capable of being supplied by two separate pumps, each of which shall be capable of maintaining an adequate supply at all times.

2.2.4.2. The arrangement of the seal and its associated fittings shall be such that it will prevent backflow of hydrocarbon vapours and will ensure the proper functioning of the seal under operating conditions.

2.2.4.3. Provision shall be made to ensure that the water seal is protected against freezing, in such a way that the integrity of seal is not impaired by overheating.

2.2.4.4. A water loop or other approved arrangement shall also be fitted to each associated water supply and drainpipe and each venting or pressure-sensing pipe leading to gas-safe spaces. Means shall be provided to prevent such loops from being emptied by a vacuum.

2.2.4.5. The deck water seal and loop arrangements shall be capable of preventing return of hydrocarbon vapours at a pressure equal to the test pressure of the cargo tanks.

2.2.4.6. In respect of paragraph 2.4.3.1.7, the Administration shall be satisfied as to the maintenance of an adequate reserve of water at all times and the integrity of the arrangements to permit the automatic formation of the water seal when the gas flow ceases. The audible and visual alarm on the low level of water in the water seal shall operate when the inert gas is not being supplied.

2.3 Installation requirements

2.3.1 Safety measures in the system

2.3.1.1. Flue gas isolating valves

Flue gas isolating valves shall be fitted in the inert gas supply mains between the boiler uptakes and the flue gas scrubber. These valves shall be provided with indicators to show whether they are open or shut, and precautions shall be taken to maintain them gas-tight and keep the seatings clear of soot. Arrangements shall be made to ensure that boiler soot blowers cannot be operated when the corresponding flue gas valve is open.

2.3.1.2. Prevention of flue gas leakage

2.3.1.2.1. Special consideration shall be given to the design and location of scrubber and blowers with relevant piping and fittings in order to prevent flue gas leakages into enclosed spaces.

2.3.1.2.2. To permit the safe maintenance, an additional water seal or other effective means of preventing flue gas leakage shall be fitted between the flue gas isolating valves and scrubber or incorporated in the gas entry to the scrubber.

2.3.1.3. Gas regulating valves

2.3.1.3.1. A gas regulating valve shall be fitted in the inert gas supply main. This valve shall be automatically controlled to close as required in paragraphs 2.3.1.5. It shall also be capable of automatically regulating the flow of inert gas to the cargo tanks unless means are provided to automatically control the speed of the inert gas blowers required in paragraph 2.2.3.

2.3.1.3.2. The valve referred to in paragraph 2.3.1.3.1 shall be located at the forward bulkhead of the forward most gas-safe space see footnote through which the inert gas supply main passes.

2.3.1.4. Non-return devices of flue gas

2.3.1.4.1. At least two non-return devices, one of which shall be a water seal, shall be fitted in the inert gas supply main, in order to prevent the return of hydrocarbon vapour to the machinery space uptakes or to any gas-safe spaces under all normal conditions of trim, list and motion of the ship. They shall be located between the automatic valve required by paragraph 2.3.1.3.1 and the aftermost connection to any cargo tank or cargo pipeline.

2.3.1.4.2. The devices referred to in paragraph 2.3.1.4.1 shall be located in the cargo area on deck.

2.3.1.4.3. The second device shall be a non-return valve or equivalent capable of preventing the return of vapours or liquids and fitted forward of the deck water seal required in paragraph 2.3.1.4.1. It shall be provided with positive means of closure. As an alternative to positive means of closure, an additional valve having such means of closure may be provided forward of the non-return valve to isolate the deck water seal from the inert gas main to the cargo tanks.

2.3.1.4.4. As an additional safeguard against the possible leakage of hydrocarbon liquids or vapours back from the deck main, means shall be provided to permit this section of the line between the valve having positive means of closure referred to in paragraph 2.3.1.4.3 and the valve referred to in paragraph 2.3.1.3 to be vented in a safe manner when the first of these valves is closed.

2.3.1.5. Automatic shutdown

2.3.1.5.1. Automatic shutdown of the inert gas blowers and gas regulating valve shall be arranged on predetermined limits being reached in respect of paragraphs 2.4.3.1.1, 2.4.3.1.2 and 2.4.3.1.3.

2.3.1.5.2. Automatic shutdown of the gas regulating valve shall be arranged in respect of paragraph 2.4.3.1.4.

2.3.1.6. Oxygen rich gas

In respect of paragraph 2.4.3.1.5, when the oxygen content of the inert gas exceeds 8% by volume, immediate action shall be taken to improve the gas quality. Unless the quality of the gas improves, all cargo tank operations shall be suspended so as to avoid air being drawn into the tanks and the isolation valve referred to in paragraph 2.3.1.4.3 shall be closed.

2.3.2 Inert gas lines

2.3.2.1. The inert gas main may be divided into two or more branches forward of the non-return devices required by paragraphs 2.2.4 and 2.3.1.4.

2.3.2.2. The inert gas supply main shall be fitted with branch piping leading to each cargo tank. Branch piping for inert gas shall be fitted with either stop valves or equivalent means of control for isolating each tank. Where stop valves are fitted, they shall be provided with locking arrangements, which shall be under the control of a responsible ship's officer. The control system shall provide unambiguous information of the operational status of such valves.

2.3.2.3. In combination carriers, the arrangement to isolate the slop tanks containing oil or oil residues from other tanks shall consist of blank flanges which will remain in position at all times when cargoes other than oil are being carried except as provided for in the relevant section of the Guidelines on inert gas systems. see footnote

2.3.2.4. Means shall be provided to protect cargo tanks against the effect of overpressure or vacuum caused by thermal variations when the cargo tanks are isolated from the inert gas mains.

2.3.2.5. Piping systems shall be so designed as to prevent the accumulation of cargo or water in the pipelines under all normal conditions.

2.3.2.6. Arrangements shall be provided to enable the inert gas main to be connected to an external supply of inert gas. The arrangements shall consist of a 250 mm nominal pipe size bolted flange, isolated from the inert gas main by a valve and located

forward of the non-return valve referred to in paragraph 2.3.1.4.3. The design of the flange should conform to the appropriate class in the standards adopted for the design of other external connections in the ship's cargo piping system.

2.3.2.7. If a connection is fitted between the inert gas supply main and the cargo piping system, arrangements shall be made to ensure an effective isolation having regard to the large pressure difference which may exist between the systems. This shall consist of two shutoff valves with an arrangement to vent the space between the valves in a safe manner or an arrangement consisting of a spool-piece with associated blanks.

2.3.2.8. The valve separating the inert gas supply main from the cargo main and which is on the cargo main side shall be a non-return valve with a positive means of closure.

2.4 Operation and control requirements

2.4.1 Indication devices

. Means shall be provided for continuously indicating the temperature and pressure of the inert gas at the discharge side of the gas blowers, whenever the gas blowers are operating.

2.4.2 Indicating and recording devices

2.4.2.1. Instrumentation shall be fitted for continuously indicating and permanently recording when inert gas is being supplied:

- .1. the pressure of the inert gas supply mains forward of the non-return devices required by paragraph 2.3.1.4.1; and
- .2. the oxygen content of the inert gas in the inert gas supply mains on the discharge side of the gas blowers.

2.4.2.2. The devices referred to in paragraph 2.4.2.1 shall be placed in the cargo control room where provided. But where no cargo control room is provided, they shall be placed in a position easily accessible to the officer in charge of cargo operations.

2.4.2.3. In addition, meters shall be fitted:

- .1. in the navigation bridge to indicate at all times the pressure referred to in paragraph 2.4.2.1.1 and the pressure in the slop tanks of combination carriers, whenever those tanks are isolated from the inert gas supply main; and
- .2. in the machinery control room or in the machinery space to indicate the oxygen content referred to in paragraph 2.4.2.1.2.

2.4.2.4. Portable instruments for measuring oxygen and flammable vapour concentration shall be provided. In addition, suitable arrangement shall be made on each cargo tank such that the condition of the tank atmosphere can be determined using these portable instruments.

2.4.2.5. Suitable means shall be provided for the zero and span calibration of both fixed and portable gas concentration measurement instruments, referred to in paragraphs 2.4.2.1 to 2.4.2.4.

2.4.3 Audible and visual alarms

2.4.3.1. For inert gas systems of both the flue gas type and the inert gas generator type, audible and visual alarms shall be provided to indicate:

- .1. low water pressure or low water flow rate to the flue gas scrubber as referred to in paragraph 2.2.2.1;
- .2. high water level in the flue gas scrubber as referred to in paragraph 2.2.2.1;
- .3. high gas temperature as referred to in paragraph 2.4.1;
- .4. failure of the inert gas blowers referred to in paragraph 2.2.3;
- .5. oxygen content in excess of 8% by volume as referred to in paragraph 2.4.2.1.2;
- .6. failure of the power supply to the automatic control system for the gas regulating valve and to the indicating devices as referred to in paragraphs 2.3.1.3 and 2.4.2.1;
- .7. low water level in the water seal as referred to in paragraph 2.3.1.4.1;
- .8. gas pressure less than 100 mm water gauge as referred to in paragraph 2.4.2.1.1. The alarm arrangement shall be such as to ensure that the pressure in slop tanks in combination carriers can be monitored at all times; and
- .9. high gas pressure as referred to in paragraph 2.4.2.1.1.

2.4.3.2. For inert gas systems of the inert gas generator type, additional audible and visual alarms shall be provided to indicate:

- .1. insufficient fuel oil supply;
- .2. failure of the power supply to the generator; and
- .3. failure of the power supply to the automatic control system for the generator.

2.4.3.3. The alarms required in paragraphs 2.4.3.1.5, 2.4.3.1.6 and 2.4.3.1.8 shall be fitted in the machinery space and cargo control room, where provided, but in each case in such a position that they are immediately received by responsible members of

the crew.

2.4.3.4. An audible alarm system independent of that required in paragraph 2.4.3.1.8 or automatic shutdown of cargo pumps shall be provided to operate on predetermined limits of low pressure in the inert gas main being reached.

2.4.4 Instruction manuals

. Detailed instruction manuals shall be provided on board, covering the operations, safety and maintenance requirements and occupational health hazards relevant to the inert gas system and its application to the cargo tank system. ^{see footnote} The manuals shall include guidance on procedures to be followed in the event of a fault or failure of the inert gas system.

FSS Code - Fire Safety Systems – Resolution MSC.98(73) - Annex - International Code For Fire Safety Systems - Chapter 16 - Fixed Hydrocarbon Gas Detection Systems

Chapter 16 - Fixed Hydrocarbon Gas Detection Systems

1 Application

1.1. This chapter details the specifications for fixed hydrocarbon gas detection systems as required by chapter II-2 of the Convention.

1.2. A combined gas detection system required by regulations II-2/4.5.7.3 and II-2/4.5.10 may be accepted in cases where the system fully complies with the requirement of regulation II-2/2 of the Convention.

2 Engineering Specifications

2.1 General

2.1.1. The fixed hydrocarbon gas detection system referred to in chapter II-2 of the Convention shall be designed, constructed and tested to the satisfaction of the Administration based on performance standards developed by the Organization ^{see footnote}.

2.1.2. The system shall be comprised of a central unit for gas measurement and analysis and gas sampling pipes in all ballast tanks and void spaces of double-hull and double-bottom spaces adjacent to the cargo tanks, including the forepeak tank and any other tanks and spaces under the bulkhead deck adjacent to cargo tanks.

2.1.3. The system may be integrated with the cargo pump-room gas detection system, provided that the spaces referred to in paragraph 2.1.2 are sampled at the rate required in paragraph 2.2.3.1. Continuous sampling from other locations may also be considered provided the sampling rate is complied with.

2.2 Component requirements

2.2.1 Gas sampling lines

2.2.1.1. Common sampling lines to the detection equipment shall not be fitted, except the lines serving each pair of sampling points as required in paragraph 2.2.1.3.

2.2.1.2. The materials of construction and the dimensions of gas sampling lines shall be such as to prevent restriction. Where non-metallic materials are used, they shall be electrically conductive. The gas sampling lines shall not be made of aluminium.

2.2.1.3. The configuration of gas sampling lines shall be adapted to the design and size of each space. Except as provided in paragraphs 2.2.1.4 and 2.2.1.5, the sampling system shall allow for a minimum of two hydrocarbon gas sampling points, one located on the lower and one on the upper part where sampling is required. When required, the upper gas sampling point shall not be located lower than 1 m from the tank top. The position of the lower located gas sampling point shall be above the height of the girder of bottom shell plating but at least 0.5 m from the bottom of the tank and it shall be provided with means to be closed when clogged. In positioning the fixed sampling points, due regard should also be given to the density of vapours of the oil products intended to be transported and the dilution from space purging or ventilation.

2.2.1.4. For ships with deadweight of less than 50,000 tonnes, the Administration may allow the installation of one sampling location for each tank for practical and/or operational reasons.

2.2.1.5. For ballast tanks in the double-bottom, ballast tanks not intended to be partially filled and void spaces, the upper gas sampling point is not required.

2.2.1.6. Means shall be provided to prevent gas sampling lines from clogging when tanks are ballasted by using compressed air flushing to clean the line after switching from ballast to cargo loaded mode. The system shall have an alarm to indicate if the gas sampling lines are clogged.

2.2.2 Gas analysis unit

2.2.2.1. The gas analysis unit shall be located in a safe space and may be located in areas outside the ship's cargo area; for example, in the cargo control room and/or navigation bridge in addition to the hydraulic room when mounted on the forward bulkhead, provided the following requirements are observed:

.1. sampling lines shall not run through gas safe spaces, except where permitted under subparagraph .5;

.2. the hydrocarbon gas sampling pipes shall be equipped with flame arresters. Sample hydrocarbon gas is to be led to the atmosphere with outlets arranged in a safe location, not close to a source of ignitions and not close to the accommodation area air intakes;

.3. a manual isolating valve, which shall be easily accessible for operation and maintenance, shall be fitted in each of the sampling lines at the bulkhead on the gas safe side;

.4. the hydrocarbon gas detection equipment including sample piping, sample pumps, solenoids, analysing units etc., shall be located in a reasonably gas-tight cabinet (e.g., fully enclosed steel cabinet with a door with gaskets) which is to be monitored by its own sampling point. At a gas concentration above 30% of the lower flammable limit inside the steel enclosure the entire gas analysing unit is to be automatically shut down; and

.5. where the enclosure cannot be arranged directly on the bulkhead, sample pipes shall be of steel or other equivalent material and without detachable connections, except for the connection points for isolating valves at the bulkhead and analysing unit, and are to be routed on their shortest ways.

2.2.3 Gas detection equipment

2.2.3.1. The gas detection equipment shall be designed to sample and analyse from each sampling line of each protected space, sequentially at intervals not exceeding 30 min.

2.2.3.2. Means shall be provided to enable measurements with portable instruments, in case the fixed system is out of order or for system calibration. In case the system is out of order, procedures shall be in place to continue to monitor the atmosphere with portable instruments and to record the measurement results.

2.2.3.3. Audible and visual alarms are to be initiated in the cargo control room, navigation bridge and at the analysing unit when the vapour concentration in a given space reaches a pre-set value, which shall not be higher than the equivalent of 30% of the lower flammable limit.

2.2.3.4. The gas detection equipment shall be so designed that it may readily be tested and calibrated.

Footnote

Footnote

Refer to the Guidelines for marine portable fire extinguishers adopted by the Organization by resolution A.602(15).

Footnote

Footnote

Refer to the Revised guidelines for the approval of equivalent fixed gas fire-extinguishing systems, as referred to in SOLAS 74, for machinery spaces and cargo pump rooms (MSC/Circ.848) and the Guidelines for the approval of fixed aerosol fire-extinguishing systems equivalent to fixed gas fire-extinguishing systems, as referred to in SOLAS 74, for machinery spaces (MSC/Circ.1007).

Footnote

Footnote

Refer to the Guidelines for performance and testing criteria and surveys of high expansion foam concentrates for fire-extinguishing systems (MSC/Circ.670).

Footnote

Footnote

Refer to the Guidelines for performance and testing criteria and surveys of low expansion foam concentrates for fire-extinguishing systems (MSC/Circ.582 and Corr.1.

Footnote

Footnote

Refer to the Alternative arrangements for halon fire-extinguishing systems in machinery spaces and pump-rooms (MSC/Circ.668) and the Revised test method for equivalent water-based fire-extinguishing systems for machinery spaces of category A and cargo pump -rooms (MSC/Circ.728).

Footnote

Footnote

Refer to the Revised Guidelines for approval of sprinkler systems equivalent to that referred to in SOLAS regulation II-2/12 as adopted by the Organization by resolution A.800(19).

Footnote

Footnote

Refer to the Code on Alarms and Indicators as adopted by the Organization by resolution A.830(19).

Footnote

Footnote

Refer to the Guidelines for the evaluation, testing and application of low-location lighting on passenger ships as adopted by the Organization by resolution A.752(18).

Footnote

Footnote

Refer to the Recommendations by the International Organization for Standardization, in particular, publication ISO 15370:2001 on Low-location lighting on passenger ships.

Footnote

Footnote

Refer to the Indication of the "assembly stations" in passenger ships (MSC/Circ.777).

Footnote

Footnote

Refer to the Guidelines for the performance and testing criteria, and surveys of low-expansion foam concentrates for fixed fire-extinguishing systems (MSC/Circ.582 and Corr.1).

Footnote

Footnote

Refer to the Guidelines for the performance and testing criteria, and surveys of medium expansion foam concentrates for fixed fire-extinguishing systems (MSC/Circ.798).

Footnote

Footnote

Refer to the Revised standards for the design, testing and locating of devices to prevent the passage of flame into cargo tanks in tankers (MSC/Circ.677) and the Revised factors to be taking into consideration when designing cargo tank venting and gas-freeing arrangements (MSC/Circ.450/Rev.1).

Footnote

Footnote

Refer to the Clarification of inert gas system requirements under the Convention (MSC/Circ.485) and to the Revised guidelines for inert gas systems (MSC/Circ.353), as amended by MSC/Circ.387.

Footnote

Footnote

A gas-safe space is a space in which the entry of hydrocarbon gases would produce hazards with regard to flammability or toxicity.

Footnote

Footnote

Refer to the Revised guidelines for inert-gas systems (MSC/Circ.353), as amended by MSC/Circ.387.

Footnote

Footnote

Refer to the Guidelines for the performance and testing criteria and surveys of low-expansion foam concentrates for fixed fire-extinguishing systems (MSC/Circ.582/Corr.1)

Footnote

Footnote

Refer to the Revised Guidelines for the approval of equivalent water-based fire-extinguishing systems for machinery spaces and cargo pump-rooms (MSC/Circ.1165).

Footnote

Footnote

Refer to the guidelines to be developed by the Organization.

Footnote

Footnote

Publication ISO – 9809/1: Refillable seamless steel gas cylinders (design, construction and testing);

ISO – 3500: Seamless steel CO₂ cylinders. For fixed fire-fighting installations on ships, specifying the principal external dimensions, accessories, filling ratio and marking for seamless steel CO₂ cylinders used in fixed fire-fighting installations on ships, in order to facilitate their interchange ability;

ISO – 5923: Fire protection – Fire-extinguishing media – Carbon dioxide;

ISO – 13769: Gas cylinders – Stamp marking;

ISO – 6406: Periodic inspection and testing of seamless steel gas cylinders;

ISO – 9329, part 1: Seamless steel tubes for pressure purposes – Technical delivery conditions – Part 1: Unalloyed steels with specified room temperature properties;

ISO – 9329, part 2: Seamless steel tubes for pressure purposes – Technical delivery conditions – Part 2: Unalloyed and alloyed steels with specified elevated temperature properties;

ISO – 9330, part 1: Welded steel tubes for pressure purposes – Technical delivery conditions – Part 1: Unalloyed steel tubes with specified room temperature properties;

ISO – 9330, part 2: Welded steel tubes for pressure purposes – Technical delivery conditions – Part 2: Electric resistance and induction welded unalloyed and alloyed steel tubes with specified elevated temperature properties.

Footnote

Footnote

Refer to the Revised guidelines for the approval of equivalent fixed gas fire-extinguishing systems, as referred to in SOLAS 74, for machinery spaces and cargo pump rooms (MSC/Circ.848) and the Guidelines for the approval of fixed aerosol fire-extinguishing systems equivalent to fixed gas fire-extinguishing systems, as referred to in SOLAS 74, for machinery spaces (MSC/Circ.1007).

Footnote

Footnote

Refer to the Guidelines for the design, construction and testing of fixed hydrocarbon gas detection system (MSC.1/Circ.1370).

Footnote

Footnote

Refer to the General requirements for electromagnetic compatibility for all electrical and electronic equipment, adopted by the Organization by resolution A.813(19).

Footnote

Footnote

Refer to the Guidelines for approval of fixed fire detection and fire alarm systems for cabin balconies (MSC.1/Circ.1242).

Footnote

Footnote

Refer to the Code on Alerts and Indicators, 2009, as adopted by the Organization by resolution A.1021(26).

Footnote

Footnote

Refer to the Guidelines for the performance and testing criteria and surveys of high-expansion foam concentrates for fixed fire-extinguishing systems (MSC/Circ.670).

Footnote

Footnote

Refer to the Guidelines for the approval of fixed high-expansion foam systems (MSC.1/Circ.1384).

Footnote

Footnote

Where the Hazen-Williams method is used, the following values of the friction factor *C* for different pipe types which may be considered should apply:

<i>Pipe type</i>	<i>C</i>
Black or galvanized mild steel	100
Copper or copper alloys	150
Stainless steel	150

Footnote

Footnote

Refer to the Revised Guidelines for the performance and testing criteria and surveys of low-expansion foam concentrates for fixed fire-extinguishing systems (MSC.1/Circ.1312).

Footnote

Footnote

Refer to the recommendations of the International Electrotechnical Commission, in particular publication IEC 60079, *Electrical Apparatus for Explosive Gas Atmospheres*.

Footnote

Footnote

Refer to the Revised guidelines for approval of fixed water-based fire-fighting systems for ro-ro spaces and special category spaces (MSC.1/Circ.1430).

Footnote

Footnote

Refer to the recommendations of the International Electrotechnical Commission, in particular publication IEC 60068-2-1 – Section one -Test Ab, *Environmental Testing – Part 2-1: Tests – Test A: Cold*.

Footnote

Footnote

Refer to the *Guidelines for performance and testing criteria and surveys of foam concentrates for fixed fire-extinguishing systems* (MSC.1/Circ.1312).
