



Ref. T4/4.03

**REVISED STANDARDS FOR THE DESIGN, TESTING AND  
LOCATING OF DEVICES TO PREVENT THE PASSAGE OF  
FLAME INTO CARGO TANKS IN TANKERS**

- 1 By resolution A.519(13) the Maritime Safety Committee was requested by the 1983 Assembly to finalize the Standards for devices to prevent the passage of flame into cargo tanks, the Committee was developing at the time, prior to the coming into force of the 1981 SOLAS amendments.
- 2 The Committee, at its forty-ninth session, (2 to 6 April 1984), adopted the standards so developed, which were attached to MSC/Circ.373.
- 3 The Committee agreed that the inert gas system was to be considered as equivalent to devices to prevent the passage of flame into cargo tanks only if vent outlets on ships fitted with inert gas systems were at least fitted with devices to prevent the passage of flame into cargo tanks, but that these devices need not comply with the test requirement for endurance burning. The Committee noted that, in the standards, emphasis was laid on compliance with test specifications rather than on construction. It was then understood that, in the case of a tanker fitted with an inert gas system, the provision of flashback would suffice and a well-designed and fitted flame screen could meet this criterion. In summary, if a flame screen met the standards, it would be accepted.
- 4 The Committee, at its fifty-fifth session, (11 to 22 April 1988), adopted amendments to the standards contained in MSC/Circ.373 and disseminated them as MSC/Circ.373/Rev.1.
- 5 The Committee, at its sixty-fourth session, (5 to 9 December 1994), recognizing the necessity to clarify some provisions in the revised standards, adopted further amendments thereto, which are incorporated in the test set out in the annex.
- 6 Member Governments are invited to give effect to the revised standards in conjunction with the application of regulation II-2/59 of the 1974 SOLAS Convention, as amended.

\*\*\*

**ANNEX**

**REVISED STANDARDS FOR THE DESIGN, TESTING AND LOCATING  
OF DEVICES TO PREVENT THE PASSAGE OF FLAME  
INTO CARGO TANKS IN TANKERS**

**CONTENTS**

**INTRODUCTION**

- 1.1 Purpose
- 1.2 Application
- 1.3 Definitions
- 2 **STANDARDS**
  - 2.1 Principles
  - 2.2 Mechanical Design Standards
  - 2.3 Performance Standards
  - 2.4 Flame Screens
  - 2.5 Sizing, location and installation of devices
- 3 **TYPE TEST PROCEDURES**
  - 3.1 Principles
  - 3.2 Test procedures for flame arresters located at openings to the atmosphere
  - 3.3 Test procedures for high velocity vents
  - 3.4 Test rig and test procedures for detonation flame arresters located in-line
  - 3.5 Operational test procedures
- 4 **MISCELLANEOUS**
  - 4. Marking of device
  - 4.2 Laboratory report
  - 4.3 Manufacturers' instruction manual

## INTRODUCTION

### 1.1 Purpose

The 1981 and the 1983 amendments to the International Convention for the Safety of Life at Sea, 1974 (SOLAS) include revised requirements for fire safety measures for tankers. Regulation II-2/59 of these amendments contains provisions concerning venting, purging, gas-freeing and ventilation. regulation II-2/59.1.5 states:

"The venting system shall be provided with devices to prevent the passage of flame into the cargo tanks. The design, testing and locating of these devices shall comply with the requirements established by the Administration which shall contain at least the Standards adopted by the Organization."

### 1.2 Application

1.2.1 These Standards are intended to cover the design, testing, locating and maintenance of "devices to prevent the passage of flame into cargo tanks" (hereafter called "devices") of tankers and combination carriers carrying crude oil and petroleum products having a flashpoint of 60°C (closed cup) or less, and a Reid vapour pressure below atmospheric pressure and other products having a similar fire hazard.

1.2.2 Oil tankers and combination carriers fitted with an inert gas system in accordance with regulation 62 should be fitted with devices which comply with these Standards, except that the tests specified in 3.2.3 and 3.3.3.2 are not required. Such devices are only to be fitted at openings unless they are tested in accordance with 3.4.

1.2.3 These Standards are intended for devices protecting cargo tanks containing crude oil, petroleum products and flammable chemicals. In the case of the carriage of chemicals, the test media referred to in section 3 can be used. However, devices for chemical tankers dedicated to the carriage of products with MESH\* less than 0.9 mm should be tested with appropriate media.

1.2.4 Devices should be tested and located in accordance with these Standards.

1.2.5 Devices are installed to protect:

- 1 openings designed to relieve pressure or vacuum caused by thermal variations (regulation II-2/59.1.2.1);
- 2 openings designed to relieve pressure or vacuum during cargo loading, ballasting or during discharging (regulation II-2/59.1.2.2);
- 3 outlets designed for gas-freeing (regulation II-2/59.2.2.3).

1.2.6 Devices should not be capable of being bypassed or blocked open unless they are tested in the bypassed or blocked open position in accordance with section 3.

---

\*Reference is made to IEC - Publication 79-

1.2.7 These Standards do not include consideration of sources of ignition such as lightning discharges since insufficient information is available to formulate equipment recommendations. All cargo handling, tank cleaning and ballasting operations should be suspended on the approach of an electrical storm.

1.2.8 These Standards are not intended to deal with the possibility of the passage of flame from one cargo tank to another on tankers with common venting systems.

1.2.9 When outlet openings of gas-freeing systems on tankers not fitted with inert gas systems are required to be protected with devices, they should comply with these Standards except that the tests specified in 3.2.3 and 3.3.3.2 are not required.

1.2.10 Certain of the tests prescribed in section 3 of these Standards are potentially hazardous, but no attempt is made in this circular to specify safety requirements for these tests.

### 1.3 Definitions

For the purpose of these Standards, the following definitions are applicable.

1.3.1 "Flame arrester" is a device to prevent the passage of flame in accordance with a specified performance standard. Its flame-arresting element is based on the principle of quenching.

1.3.2 "Flame screen" is a device utilizing wire mesh to prevent the passage of unconfined flames, in accordance with a specified performance standard.

1.3.3 "Flame speed" is the speed at which a flame propagates along a pipe or other system.

1.3.4 "Flashback" is the transmission of a flame through a device.

1.3.5 "High velocity vent" is a device to prevent the passage of flame, consisting of a mechanical valve which adjusts the opening available for flow in accordance with the pressure at the inlet of the valve in such a way that the efflux velocity cannot be less than 30 m/s.

1.3.6 "Pressure/vacuum valve"\* is a device designed to maintain pressure and vacuum in a closed container within preset limits.

## 2 STANDARDS

### 2.1 Principles

2.1.1 Depending on their service and location, devices are required to protect against the propagation of:

moving flames; and/or

2 stationary flames from pre-mixed gases;

after ignition of gases resulting from any cause.

---

\*Pressure/vacuum valves are devices to prevent the passage of flame when designed and tested in accordance with these Standards.

2.1.2 When flammable gases from outlets ignite, the following four situations may occur

At low gas velocities, the flame may:

- 1 flashback; or
  - 2 stabilize itself as if the outlet were a burner.
- 2 At high velocities, the flame may
- burn at a distance above the outlet; or
  - 2 be blown out.

2.1.3 In order to prevent the passage of flame into a cargo tank, devices must be capable of performing one or more of the following functions:

- 1 permitting the gas to pass through passages without flashback and without ignition of the gases on the protected side when the device is subjected to heating for a specified period;
- 2 maintaining an efflux velocity in excess of the flame speed for the gas, irrespective of the geometric configuration of the device and without the ignition of gases on the protected side when the device is subjected to heating for a specified period; and
- 3 preventing an influx of flame when conditions of vacuum occur within the cargo tanks.

## 2.2 Mechanical design standards

2.2.1 The casing or housing of devices should meet similar standards of strength, heat resistance and corrosion resistance as the pipe to which they are attached.

2.2.2 The design of devices should allow for ease of inspection and removal of internal elements for replacement, cleaning or repair.

2.2.3 All flat joints of the housing should be machined true and should provide for a joint having an adequate metal-to-metal contact.

2.2.4 Flame arrester elements should fit in the housing in such a way that flame cannot pass between the element and the housing.

2.2.5 Resilient seals may be installed only if their design is such that if the seals are partially or completely damaged or burned, the device is still capable of effectively preventing the passage of flame.

2.2.6 Devices should allow for efficient drainage of moisture without impairing their efficiency to prevent the passage of flame.

2.2.7 The casing and element and gasket materials should be capable of withstanding the highest pressure and temperature to which the device may be exposed under both normal and specified fire test conditions.

2.2.8 End-of-line devices should be so constructed as to direct the efflux vertically upwards.

2.2.9 Fastenings essential to the operation of the device, i.e. screws, etc., should be protected against loosening.

2.2.10 Means should be provided to check that any valve lifts easily without remaining in the open position.

2.2.11 Devices in which the flame arresting effect is achieved by the valve function and which are not equipped with the flame arrester elements (e.g. high velocity valves) must have a width of the contact area of the valve seat of at least 5 mm.

2.2.12 Devices should be resistant to corrosion in accordance with 3.5.1

2.2.13 Elements, gaskets and seals should be of material resistant to both seawater and the cargoes carried.

2.2.14 The casing or housing should be capable of passing a hydrostatic pressure test, as required in 3.5.2.

2.2.15 In-line devices should be able to withstand, without damage or permanent deformation, the internal pressure resulting from detonation when tested in accordance with section 3.4.

2.2.16 A flame arrester element should be designed to ensure quality control of manufacture to meet the characteristics of the prototype tested, in accordance with these Standards.

### 2.3 Performance Standards

2.3.1 Devices should be tested in accordance with 3.5 and thereafter shown to meet the test requirements of 3.2 to 3.4, as appropriate.

2.3.2 Performance characteristics, such as the flow rates under both positive and negative pressure, operating sensitivity, flow resistance and velocity should be demonstrated by appropriate tests.

2.3.3 Devices should be designed and constructed to minimize the effect of fouling under normal operating conditions. Instructions on how to determine when cleaning is required and the method of cleaning should be provided for each device in the manufacturers' instruction manual.

2.3.4 Devices should be capable of operating in freezing conditions (such as may cause blockage by freezing cargo vapours or by icing in bad weather) and if any device is provided with heating arrangements so that its surface temperature exceeds 85°C, then it should be tested at the highest operating temperature.

2.3.5 Devices based upon maintaining a minimum velocity should be capable of opening in such a way that a velocity of 30 m/s is immediately initiated, maintaining an efflux velocity of at least 30 m/s at all

flow rates and, when the gas flow is interrupted, be capable of closing in such a way that this minimum velocity is maintained until the valve is fully closed.

2.3.6 In the case of high velocity vents, the possibility of inadvertent detrimental hammering\* leading to damage and/or failure should be considered, with a view to eliminating it.

## 2.4 Flame screens

2.4.1 Flame screens should be:

- 1 designed in such a manner that they cannot be inserted improperly in the opening;
- 2 securely fitted in openings so that flames cannot circumvent the screen;
- 3 able to meet the requirements of these standards. For flame screens fitted at vacuum inlets through which vapours cannot be vented the test specified in 3.2.3 need not be complied with; and
- 4 be protected against mechanical damage.

## 2.5 Sizing, location and installation of devices

2.5.1 For determining the size of devices to avoid inadmissible pressure or vacuum in cargo tanks during loading or discharging, calculations of pressure losses should be carried out. The following parameters should be taken into account:

- 1 loading/discharge rates;
- 2 gas evolution;
- 3 pressure loss across devices, taking into account the resistance coefficient;
- 4 pressure loss in the vent piping system;
- 5 pressure at which the vent opens if a high velocity valve is used;
- 6 density of the saturated vapour/air mixture; and
- 7 to compensate for possible fouling of a flame arrester, 70% of its rated performance is to be used in the pressure drop calculation of the installation.

2.5.2 Devices should be located at the outlets to atmosphere unless tested and approved for in-line installation. Devices for in-line installation may not be fitted at the outlets to atmosphere unless they have also been tested and approved for that position.

---

\*Hammering is rapid full stroke opening/closing, not intended by the manufacturer during normal operations.

2.5.3 End of line devices which are intended for exclusive use at openings of inerted cargo tanks need not be tested against endurance burning as specified in 3.2.3.

2.5.4 Where end-of-line devices are fitted with cowls, weather hoods and deflectors, etc. these attachments should be fitted for the tests described in 3.2.

2.5.5 Where detonation flame arresters are installed, as in-line devices venting to atmosphere, they should be located at a sufficient distance from the open end of the pipeline so as to preclude the possibility of a stationary flame resting on the arrester.

2.5.6 When venting to atmosphere is not performed through an end-of-line device according to 2.5.4, or a detonation flame arrester according to 2.5.5, the in-line device has to be specifically tested with the inclusion of all pipes, tees, bends, cowls, weather hoods, etc., which may be fitted between the device and atmosphere. The testing should consist of the flashback test of 3.2.2 and, if for the given installation it is possible for a stationary flame to rest on the device, the testing should also include the endurance burning test of 3.2.3.

2.5.7 Means should be provided to enable personnel to reach devices situated more than 2 m above deck to facilitate maintenance, repair and inspection.

### 3 TYPE TEST PROCEDURES

#### 3.1 Principles

3.1.1 Tests should be conducted by a laboratory acceptable to the Administration.

3.1.2 Each size of each model should be submitted for type testing. However, for flame arresters testing may be limited to the smallest and the largest sizes and one additional size in between to be chosen by the Administration. Devices should have the same dimensions and most unfavourable clearances expected in the production model. If a test device is modified during the test programme, the testing should be started over again.

3.1.3 Tests described in this section using gasoline vapours (a non-leaded petroleum distillate consisting essentially of aliphatic hydrocarbon compounds with a boiling range approximating 65°C/75°C), technical hexane vapours, or technical propane, as appropriate, and referred to in this section, are suitable for all devices protecting tanks containing a flammable atmosphere of the cargoes referred to in 1.2.1. This does not preclude the use of gasoline vapours or technical hexane vapours for all tests referred to in this section.

3.1.4 After the relevant tests, the device should not show mechanical damage that affects its original performance.

3.1.5 Before the tests the following equipment as appropriate should be properly calibrated:

gas concentration meters;

2 thermometers;

3 flow meters;

- 4 pressure meters; and
- 5 time recording devices

3.1.6 The following characteristics should be recorded, as appropriate, throughout the tests

- 1 concentration of fuel in the gas mixture;
- 2 temperature of the test gas mixture at inflow of the device; and
- 3 flow rates of the test gas mixtures when applicable.

3.1.7 Flame passage should be observed by recording, e.g., temperature, pressure, or light emission by suitable sensors on the protected side of the device; alternatively, flame passage may be recorded on video tape.

## 3.2 Test procedures for flame arresters located at openings to the atmosphere

3.2.1 The test rig should consist of an apparatus producing an explosive mixture, a small tank with a diaphragm, a flanged prototype of the flame arrester, a plastic bag<sup>\*</sup> and a firing source in three positions (see appendix 1)<sup>\*\*</sup>. Other test rigs may be used, provided the tests referred to in this section are achieved to the satisfaction of the Administration.

3.2.2 A flashback test should be carried out as follows:

- 1 The tank, flame arrester assembly and the plastic bag<sup>\*</sup> enveloping the prototype flame arrester should be filled so that this volume contains the most easily ignitable propane/air mixture<sup>\*\*\*</sup>. The concentration of the mixture should be verified by appropriate testing of the gas composition in the plastic bag. Where devices referred to in 2.5.6 are tested, the plastic bag should be fitted at the outlet to atmosphere. Three ignition sources should be installed along the axis of the bag, one close to the flame arrester, another as far away as possible therefrom, and the third at the midpoint between these two. These three sources should be fired in succession, twice in each of the three positions. The temperature of the test gas should be within the range of 15°C to 40°C.
- 2 If a flashback occurs, the tank diaphragm will burst and this will be audible and visible to the operator by the emission of a flame. Flame, heat and pressure sensors may be used as an alternative to a bursting diaphragm.

<sup>\*</sup>The dimensions of the plastic bag are dependent on those of the flame arrester, but for the flame arresters normally used on tankers, the plastic bag may have a circumference of 2 m, a length of 2.5 m and a wall thickness of 0.05 m.

<sup>\*\*</sup>In order to avoid remnants of the plastic bag from falling back on to the device being tested after ignition of the fuel/air mixture, it may be useful to mount a coarse wire frame across the device within the plastic bag. The frame should be so constructed as not to interfere with the test result.

<sup>\*\*\*</sup>Reference is made to IEC Publication 79-

3.2.3 An endurance burning test should be carried out, in addition to the flashback test, for flame arresters at outlets where flows of explosive vapour are foreseeable:

The test rig as referred to in 3.2.1 may be used, without the plastic bag. The flame arrester should be so installed that the mixture emission is vertical. In this position the mixture should be ignited. Where devices referred to in 2.5.6 are tested, the flame arrester should be so installed as to reflect its final orientation.

- .2 Endurance burning should be achieved by using the most easily ignitable gasoline vapour/air mixture or the most easily ignitable technical hexane vapour/air mixture with the aid of a continuously operated pilot flame or a continuously operated spark igniter at the outlet. The test gas should be introduced upstream of the tank shown in appendix 2. Maintaining the concentration of the mixture as specified above, by varying the flow rate, the flame arrester should be heated until the highest obtainable temperature on the cargo tank side of the arrester is reached. Temperatures should be measured, for example, at the protected side of the flame quenching matrix of the arrester (or at the seat of the valve in case of testing high velocity vents according to 3.3). The highest obtainable temperature may be considered to have been reached when the rate of rise of temperature does not exceed 0.5° C per minute over a ten-minute period. This temperature should be maintained for a period of ten minutes, after which the flow should be stopped and the conditions observed. The temperature of the test gas should be within the range of 15°C to 40°C.

If no temperature rise occurs at all: inspect the arrester for a more adequate position of the temperature sensor, taking account of the visually registered position of the stabilized flame during the first test sequence. Positions which require the drilling of small holes into fixed parts of the arrester have to be taken into account. If all this is not successful, affix the temperature sensor at the unprotected side of the arrester in a position near to the stabilized flame.

If difficulties arise in establishing stationary temperature conditions (at elevated temperatures), the following criteria should apply: using the flow rate which produced the maximum temperature during the foregoing test sequence, endurance burning should be continued for a period of two hours from the time the above-mentioned flow rate has been established. After that period the flow should be stopped and the conditions observed. Flashback should not occur during this test.

3.2.4 When a pressure or/and vacuum valve is integrated to a flame arresting device, the flashback test has to be performed with the pressure or/and vacuum valve blocked open. If there are no additional flame quenching elements integrated in a pressure valve, this valve has to be considered and tested as a high velocity vent valve according to paragraph 3.3.

### 3.3 Test procedures for high velocity vents

3.3.1 The test rig should be capable of producing the required-volume flow rate. In appendices 2 and 3, drawings of suitable test rigs are shown. Other test rigs may be used, provided the tests are achieved to the satisfaction of the Administration.

3.3.2 A flow condition test should be carried out with high velocity vents using compressed air or gas at agreed flow rates. The following should be recorded:

The flow rate. Where air or a gas other than vapours of cargoes with which the vent is to be used is employed in the test, the flow rates achieved should be corrected to reflect the vapour density of such cargoes.

- 2 The pressure before the vent opens. The pressure in the test tank on which the device is located should not rise at a rate greater than 0.01 N/mm<sup>2</sup>/min.
- 3 The pressure at which the vent opens.
- 4 The pressure at which the vent closes.
- 5 The efflux velocity at the outlet which should not be less than 30 m/s at any time when the valve is open.

3.3.3 The following fire safety tests should be conducted while adhering to 2.3.6 using a mixture of gasoline vapour and air or technical hexane vapour and air, which produces the most easily ignitable mixture at the point of ignition. This mixture should be ignited with the aid of a permanent pilot flame or a spark igniter at the outlet:

- 1 Flashback tests in which propane may be used instead of gasoline or hexane should be carried out with the vent in the upright position and then inclined at 10° from the vertical. For some vent designs further tests with the vent inclined in more than one direction may be necessary. In each of these tests the flow should be reduced until the vent closes and the flame is extinguished, and each should be carried out at least 50 times. The vacuum side of combined valves should be tested in accordance with 3.2.2 with the vacuum valve maintained in the open position for the duration of this test, in order to test the efficiency of the device which must be fitted.
- 2 An endurance burning test, as described in 3.2.3, should be carried out. Following this test, the main flame should be extinguished and then, with the pilot flame burning or the spark igniter discharging, small quantities of the most easily ignitable mixture should be allowed to escape for a period of ten minutes maintaining a pressure below the valve of 90% of the valves opening setting, during which time flashback should not occur. For the purposes of this test the soft seals or seats should be removed.

#### 3.4 Test rig and test procedures for detonation flame arresters located in-line

3.4.1 A flame arrester should be installed at one end of a pipe of suitable length and of the same diameter as the flange of the flame arrester. On the opposed flange a pipe of a length corresponding to 10 pipe diameters should be affixed and be closed by a plastic bag\* or diaphragm. The pipe should be filled with the most easily ignitable mixture of propane and air, which should then be ignited. The velocity of the flame near the flame arrester should be measured and should have a value of that for stable detonations.

3.4.2 Three detonation tests should be conducted and no flashback should occur through the device and no part of the flame arrester should be damaged or show permanent deformation.

---

\*The dimensions should be at least 4 m circumference, 4 m length and a material wall thickness of 0.05 mm.

3.4.3 A drawing of the test rig is shown in appendix 4. Other test rigs may be used provided the tests are achieved to the satisfaction of the Administration.

### 3.5 Operational test procedures

3.5.1 A corrosion test should be carried out. In this test a complete device, including a section of the pipe to which it is fitted, should be exposed to a 5% sodium chloride solution spray at a temperature of 25°C for a period of 240 hours, and allowed to dry for 48 hours. An equivalent test may be used to the satisfaction of the Administration. Following this test, all movable parts should operate properly and there should be no corrosion deposits which cannot be washed off.

3.5.2 A hydraulic pressure test should be carried out in the casing or housing of a sample device, in accordance with 2.2.1.

## 4 MISCELLANEOUS

### 4.1 Marking of device

Each device should be permanently marked, or have a permanently fixed tag made of stainless steel or other corrosion-resistant material, to indicate:

- manufacturer's name or trade mark;
- .2 style, type, model or other manufacturer's designation for the device;
- .3 size of the outlet for which the device is approved;
- .4 approved location for installation, including maximum or minimum length of pipe, if any, between the device and the atmosphere;
- .5 direction of flow through the device;
- .6 indication of the test laboratory and report number; and
- .7 compliance with the requirements of MSC/Circ.373/Rev.2.

### 4.2 Laboratory report

4.2.1 The laboratory report should include:

- 1 detailed drawings of the device;
- .2 types of tests conducted. Where in-line devices are tested, this information should include the maximum pressures and velocities observed in the test;
- .3 specific advice on approved attachments;
- .4 types of cargo for which the device is approved.

- .5 drawings of the test rig;
- .6 in the case of high velocity vent, the pressures at which the device opens and closes in the efflux velocity; and
- .7 all the information marked on the device in 4.1

#### 4.3 Manufacturer's instruction manual

4.3.1 The manufacturer should supply a copy of the instruction manual, which should be kept on board the tanker and which should include:

- 1 installation instructions;
- .2 operating instructions;
- .3 maintenance requirements, including cleaning (see 2.3.3);
- .4 copy of the laboratory report referred to in 4.2; and
- 5 flow test data, including flow rates under both positive and negative pressures, operating sensitivity, flow resistance and velocity, should be provided.

✈

Appendix

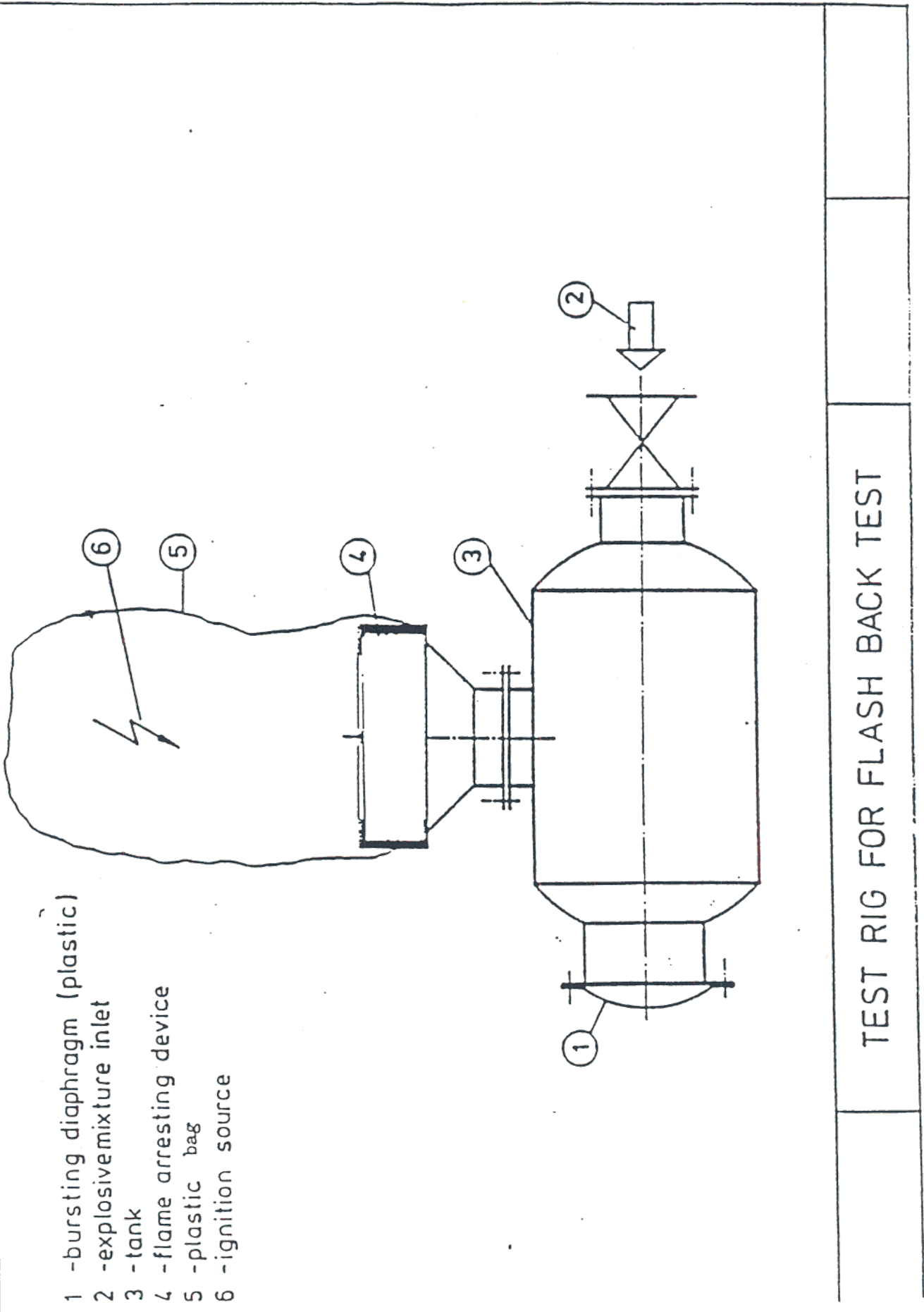

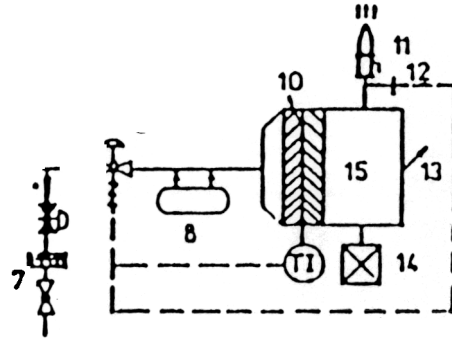
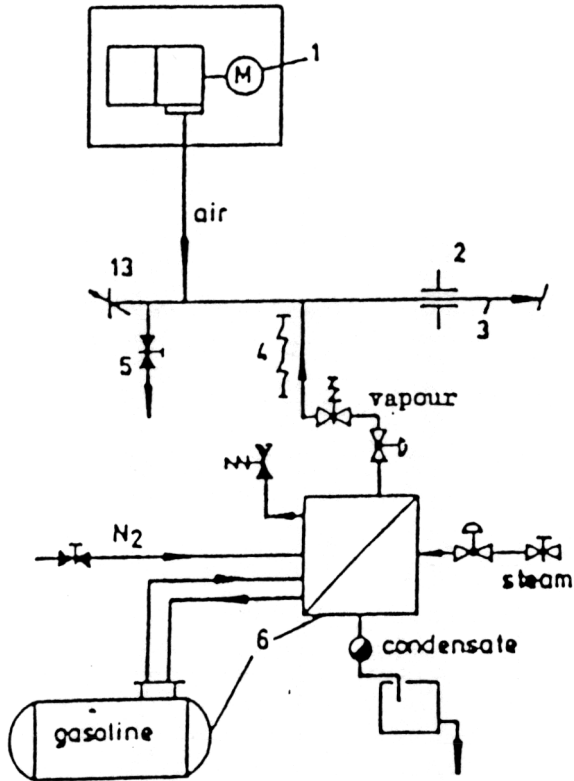

- fan with variable speed
- volume rate indicator
- pipe (500 mm diameter), length ~ 30 m
- heated vapour pipe
- air bypass
- evaporator and liquid storage tank
- vapour/air-mixture bypass
- extinguishing agents
- control and quick action stop valve
- 10 explosion arresting crimped ribbon with temperature control for the safety of the test plant
- 11 high velocity valve to be tested
- 12 flame detector
- 13 bursting diaphragm
- 14 concentration indicator
- 15 tank

Appendix 2

Schematic Plan of the Test Plant for High Velocity Valves  
(endurance burning test only)

TEST RIG FOR HIGH VELOCITY VENTS

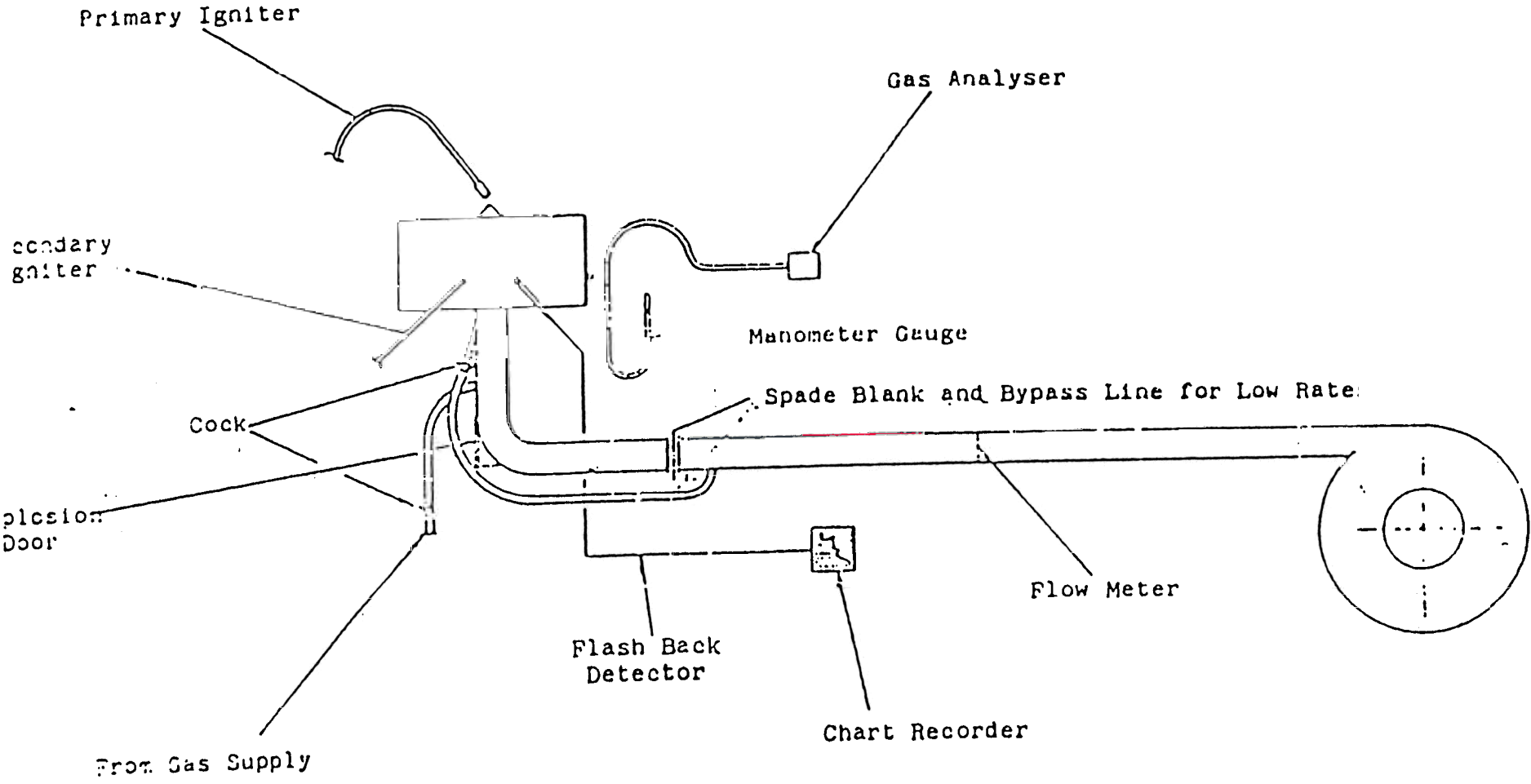

Appendix 3

Appendix 4

